

**NASA TECHNICAL NOTE**



**NASA TN D-6081**

*2.1*

**NASA TN D-6081**

**LOAN COPY: RETURN  
AFWL (WLOL)  
KIRTLAND AFB, N**



# SERVO SYSTEM DESIGN OF A HIGH-RESPONSE SLOTTED-PLATE OVERBOARD BYPASS VALVE FOR A SUPERSONIC INLET

*by George H. Neiner  
Lewis Research Center  
Cleveland, Ohio 44135*





0132971

1. Report No. NASA TN D-6081	2. Government Accession No.	3. Recipient's Catalog No.	
4. Title and Subtitle <b>SERVO SYSTEM DESIGN OF A HIGH-RESPONSE SLOTTED-PLATE OVERBOARD BYPASS VALVE FOR A SUPERSONIC INLET</b>		5. Report Date November 1970	
		6. Performing Organization Code	
7. Author(s) George H. Neiner		8. Performing Organization Report No. E-5529	
		10. Work Unit No. 720-03	
9. Performing Organization Name and Address Lewis Research Center National Aeronautics and Space Administration Cleveland, Ohio 44135		11. Contract or Grant No.	
		13. Type of Report and Period Covered Technical Note	
12. Sponsoring Agency Name and Address National Aeronautics and Space Administration Washington, D. C. 20546		14. Sponsoring Agency Code	
		15. Supplementary Notes	
16. Abstract <p>The servosystem design of a high-response airflow bypass valving system for supersonic mixed-compression inlets or other industrial or aerospace pneumatic systems is described. The valve utilizes a multislotted plate to achieve flow area change with minimum stroke and mass of moving parts. The servosystem utilizes a hydraulic piston-in-cylinder actuator close-coupled to a two-stage electrohydraulic servovalve. Using electronic compensation the small-amplitude response of the system, modulating 14 percent of its full flow area, is flat within 0 to -3 dB to 110 Hz. Full valve flow area was 25 in.<sup>2</sup> (161 cm<sup>2</sup>). A mathematical model of the system is presented and analytical responses are compared with experimental data.</p>			
17. Key Words (Suggested by Author(s)) Supersonic inlet bypass system, Bypass valve servosystem design		18. Distribution Statement Unclassified - unlimited	
19. Security Classif. (of this report) Unclassified	20. Security Classif. (of this page) Unclassified	21. No. of Pages 22	22. Price* \$3.00

# SERVOSYSTEM DESIGN OF A HIGH-RESPONSE SLOTTED-PLATE OVERBOARD BYPASS VALVE FOR A SUPERSONIC INLET

by George H. Neiner

Lewis Research Center

## SUMMARY

Investigating the dynamics and control of supersonic mixed-compression inlets where the control system hardware is not the limiting factor for system performance has indicated that it is necessary to develop high-response disturbance and control devices. A simulation of a particular inlet showed that the dynamics of interest occur from zero to 100 hertz.

The servosystem design of a high-response inlet airflow bypass valve system for a supersonic mixed-compression inlet is described. The bypass valve area was choked. Since the valve area is proportional to valve displacement, a position-type servosystem could regulate airflow so that airflow would be proportional to valve displacement.

With electronic compensation the response of the bypass valve position servosystem was extended to its maximum performance limit. At this point the servosystem performance is limited by the servovalve flapper flow limit. The servosystem response is flat within 0 to -3 decibels to 110 hertz.

A mathematical model of the linear servosystem is derived. The root-locus technique is used to determine the compensation necessary for stable closed-loop operation. The analytical servosystem response is presented and is compared with experimental performance data.

## INTRODUCTION

This report presents the servosystem design of a high-response inlet airflow bypass system for a supersonic mixed-compression inlet. Figure 1 is an isometric drawing of the inlet for which the bypass valve system was designed. The function of the inlet is to capture air at a free-stream Mach number of 2.5 and raise its static pressure while reducing its velocity to a subsonic range suitable to be supplied to the engine's compressor. This inlet has a cowl lip diameter of 18.6 inches (47.2 cm). Its capture area was 272 square inches ( $1754 \text{ cm}^2$ ) and it had a design capture corrected airflow of 35.5

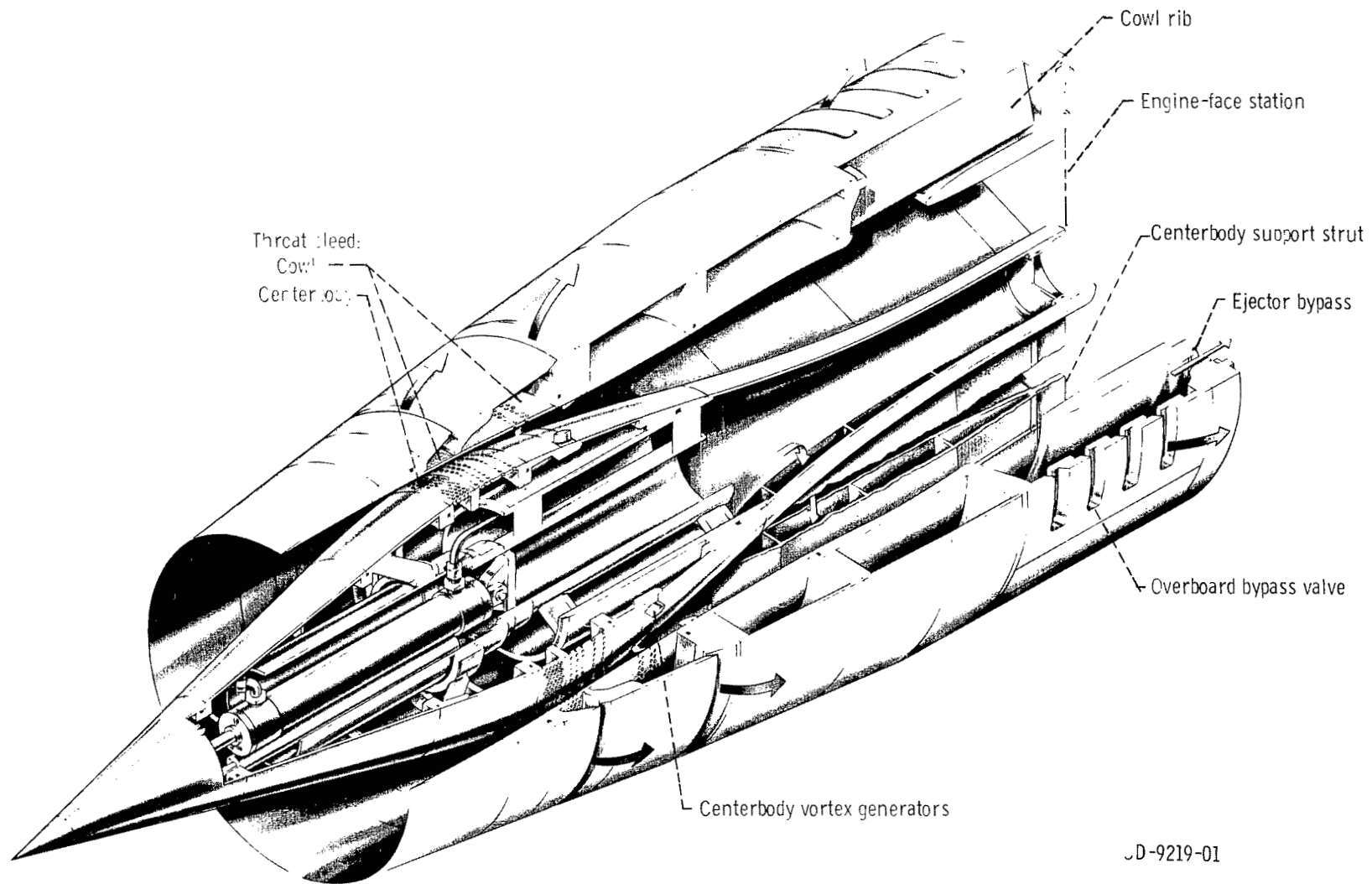

Figure 1. - Isometric of 40 to 60 mixed-compression axisymmetric inlet on which the bypass valve servosystem was used.

pounds per second (16.2 kg/sec). Forty percent of the supersonic area contraction was external, while 60 percent was internal. Additional aerodynamic information about the inlet can be found in references 1 and 2.

The function of the inlet bypass valve system is to match the airflow of the inlet to that required by the engine. Matching of the airflows is accomplished by bleeding a portion of the airflow overboard through bypass valves. These valves are located in the aft portion of the inlet subsonic diffuser. Six symmetrically located valves were used, having a total flow area of approximately 150 square inches (967 cm<sup>2</sup>). In normal operation the bypass valve area is choked. This results in bypass valve airflow being proportional to valve displacement.

An analytical representation of inlet dynamics is presented in reference 3. The inlet simulation indicated that the inlet had a number of resonances (45, 70, 120, 170, 270, and 440 Hz, and others at higher frequencies). The significant dynamics of interest occurred from 0 to 100 hertz. Since this inlet was designed for a series of experimental test programs to investigate the dynamics and control of a supersonic mixed-compression inlet (refs. 4 to 8), certain dynamic capabilities were required of the inlet bypass valve system.

Investigating the dynamics and control of this inlet then required that both the disturbance and control devices be capable of operating over a range of frequencies to 100 hertz. Of the six inlet bypass valves symmetrically located around the circumference of the inlet diffuser exit, three alternate valves were used for a disturbance device and the other three for control.

To achieve the high-response requirements, a hydraulic piston-in-cylinder actuator operating with a high-performance, two-stage electrohydraulic servovalve was selected to actuate each inlet bypass valve. In designing high-response electrohydraulic position servosystems, it is desirable to minimize the weight of the moving elements, the actuator displacement, and the hydraulic line lengths. Of the geometries considered, the flat plate resulted in minimum inertia loads. To obtain the required area variations with small actuator displacements, it was necessary to use a multiple-slot valve. This results in high valve gain (or inlet bypass valve area to valve displacement ratio). After reducing the weight and displacement, the actuator was close-coupled to the servovalve to minimize the effect of the entrapped hydraulic coupling volumes.

Thus the servosystem response now becomes dependent on physical component limitations. These limitations are presented for this particular servosystem. In addition, a mathematical model of the linear system is derived. The root-locus technique is then used to determine the servoloop compensation required for stable operation. A comparison of analytical and experimental closed-loop dynamic performance is made by means of Bode plots. Experience from various test programs using this inlet bypass valve system pointed up some practical mechanical deficiencies. Problem areas requiring the designers' attention in future applications are therefore discussed.

## VALVE DESIGN AND SERVOSYSTEM COMPONENTS

Figure 2 is an isometric drawing of a bypass valve assembly, its actuator and feedback transducer. Figure 3 is a schematic representation of the inlet bypass valve system. The bypass valve installation is further clarified by figure 4. In this case, access doors on the side of the inlet nacelle have been removed to show the mounting of some of the servosystem components. From these figures it can be seen how the plate valve is used to bypass air from the inlet in response to linear motion of the servoactuator. The valve-moving element is supported by roller bearings which run in slots in the valve stationary element. When the valve is closed, a pressure difference of approximately 1 atmosphere exists in a direction to force the two plates together. The inner plate was designed with sufficient thickness to prevent metal-to-metal contact due to this pressure loading. The weight and slot dimensions of one of the four slot inlet bypass valves are as follows:

Mass of moving parts (valve, linkage, and actuator piston), lb (kg) . . . . .	6.07 (2.75)
Slot length, in. (cm) . . . . .	6.25 (15.9)
Slot width, in. (cm) . . . . .	1.00 (2.54)
Valve full flow area, in. <sup>2</sup> (cm <sup>2</sup> ) . . . . .	25 (161)
Valve area to position gain, in. <sup>2</sup> /in. (cm <sup>2</sup> /cm) . . . . .	25 (63.4)

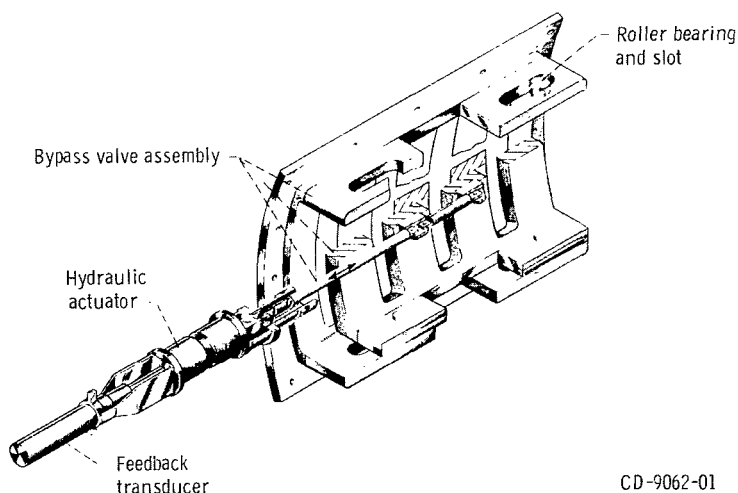

Figure 2. - Overboard bypass valve assembly and actuator.

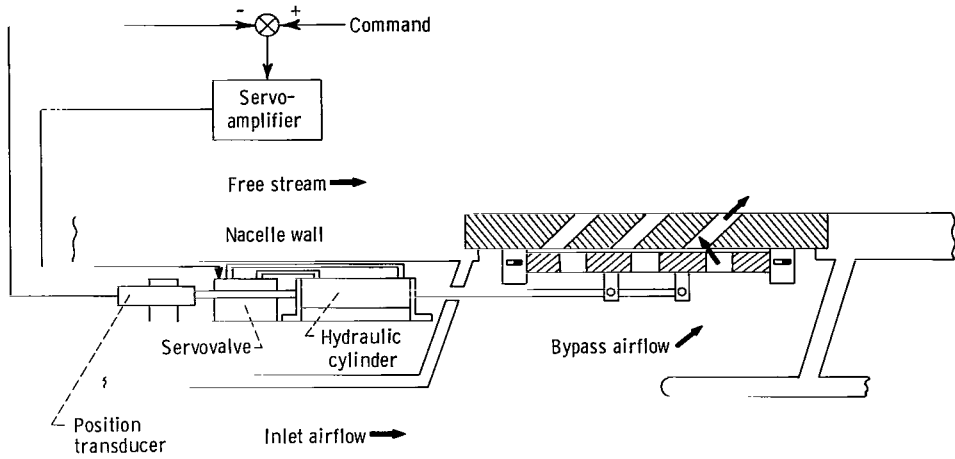

Figure 3. - Schematic of bypass valve servosystem.

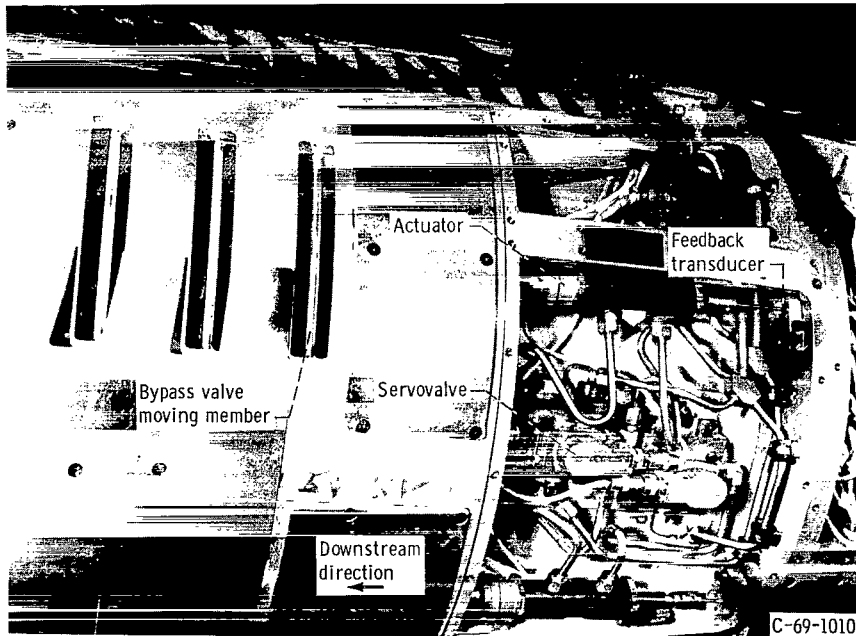

Figure 4. - Bypass valve installation on inlet.

The actuator was a commercial piston-in-cylinder type having a piston area of 0.33 square inch ( $2.13 \text{ cm}^2$ ). It could therefore develop a stall force of approximately 1000 pounds (4448 N) when subjected to a hydraulic supply pressure of 3000 psi ( $2068 \text{ N/cm}^2$ ). This stall force degraded the mechanical reliability of the bypass valve assembly. As a result the stall force was reduced to 667 pounds (2965 N) by reducing the supply pressure to 2000 psi ( $1379 \text{ N/cm}^2$ ).

A linear variable differential transformer was used for feedback of piston position. This device operates by changing the magnetic coupling between the coils of a transformer as the position of a slug of magnetic material is changed.

The servovalve used was a commercially available two-stage electrohydraulic servovalve rated at 12.6 cubic inches per second ( $206 \text{ cm}^3/\text{sec}$ ) with a supply pressure of 2000 psia ( $1379 \text{ N/cm}^2$ ) when 1333 psia ( $919 \text{ N/cm}^2$ ) pressure difference exists across the load. The servoamplifier was a modular solid-state unit (ref. 9) designed to be used in high-performance multiloop electrohydraulic servosystems.

## MAXIMUM SYSTEM PERFORMANCE ENVELOPE

Design of a high-performance servosystem can be approached as a two-phase task. The first phase consists of selecting mechanical components which have the capability of achieving a certain desired performance envelope (the amplitudes and frequencies at which it is possible to operate the system). This initial task is usually accomplished on a trial-and-error basis. For a given load mass and hydraulic supply pressure, choose a piston area and servovalve model; then determine the resulting piston acceleration, piston velocity, and servovalve flapper flow limit lines.

As pointed out in reference 10, the servovalve flapper flow limit is one which is inherent in two-stage electrohydraulic servosystems but is frequently overlooked in conventional servosystem design practice. Reference 10 also shows how actuator piston area can be selected by an optimization technique when supply pressure, load mass, and servovalve capability have been selected.

The second phase of the task is to determine the linear servoloop compensation by which the servomechanical components can be driven to the limits of the previously established maximum performance envelope.

Figure 5 is a schematic of the inlet bypass valve servosystem. The system variables are indicated in the figure, and along with all other symbols are defined in the appendix. In the case of the bypass valve servosystem, the friction forces are small. Thus in determining the maximum system performance envelope, the system can be considered as a positioning servosystem having only inertial forces. This is the same type of system described in reference 10. Therefore, the three limit equations derived



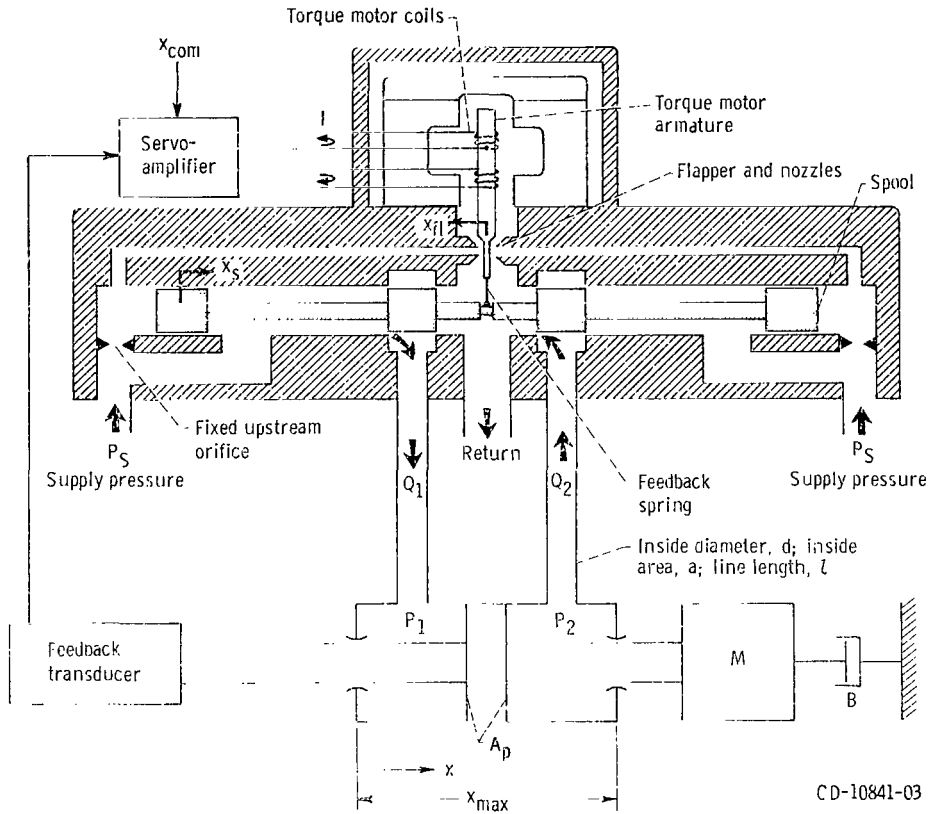

Figure 5. - Inlet bypass valve servosystem schematic showing system variables.

in reference 10 to determine the system performance envelope are listed here:

$$\frac{Q_r}{A_p} = X_o \omega \quad (\text{Conservative piston velocity limit relation}) \quad (1)$$

$$\frac{2A_p P_S}{3M} = X_o \omega^2 \quad (\text{Piston acceleration limit relation}) \quad (2)$$

$$\frac{K_{fl} K_s x_{fl, \max}}{A_p A_s} = X_o \omega^2 \quad (\text{Conservative flapper flow limit relation}) \quad (3)$$

In equation (1) the value of  $Q_r$  which is used in conventional design practice is calculated on the basis of one-third of the supply pressure existing across the servovalve orifices. In the case of the bypass valve system, the load is primarily an inertia. Thus the maximum pressure across the load due to its acceleration occurs at the ends of the

stroke. The maximum velocity occurs when the actuator is at midposition. At this time the piston is running free, and thus most of the supply pressure is across the servovalve orifices. Therefore, it is assumed that three-fourths of the supply pressure exists across the servovalve orifices for this application. Accordingly, maximum valve flow is

$$\left(\sqrt{3/4} / \sqrt{1/3}\right) Q_r = 1.5 Q_r$$

Thus, equation (3) becomes

$$\frac{1.5 Q_r}{A_p} = X_o \omega \quad \text{(Modified piston velocity limit relation)} \quad (4)$$

For the same reason as discussed for the term  $Q_r$ , the  $K_s$  term in equation (3) as taken from reference 10 was replaced by  $1.5 K_s$  for the flapper flow limit as applied in

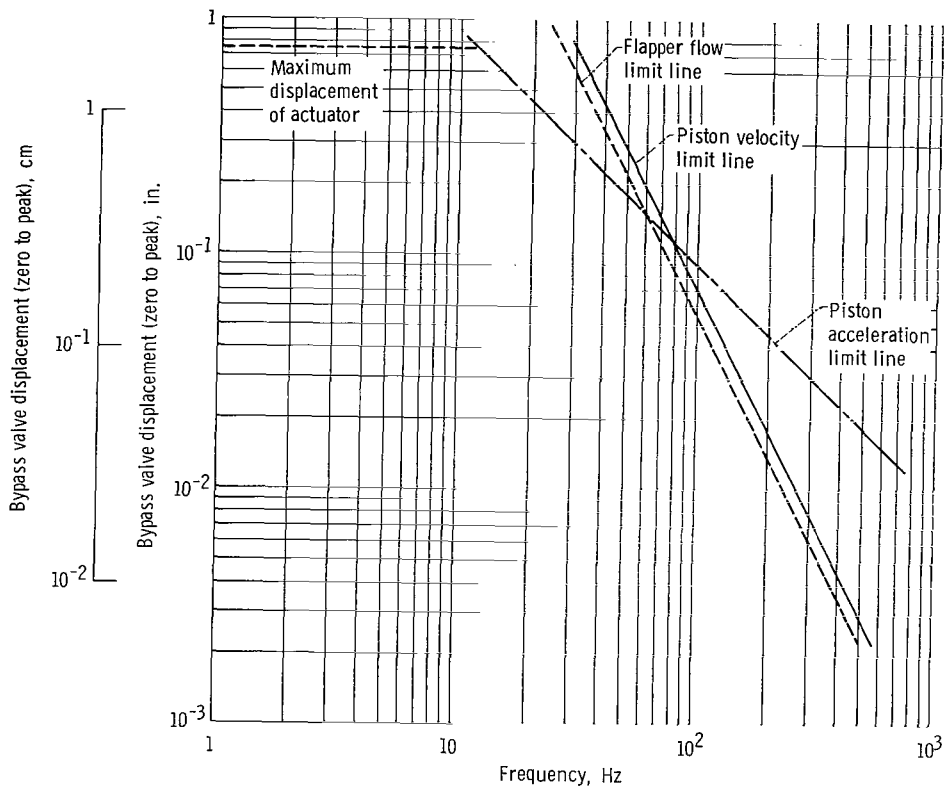

Figure 6. - Maximum system performance envelope: piston velocity, piston acceleration, and flapper flow limit lines. Supply pressure, 2000 psi (1379 N/cm<sup>2</sup>); rated flow, 12.6 cubic inches per second (206 cm<sup>3</sup>/sec); piston area, 0.331 square inch (2.14 cm<sup>2</sup>); actuator pressure drop for rated flow, 1333 psi (919 N/cm<sup>2</sup>).

this report. This results in the modified flapper flow limit relation of equation (5):

$$\frac{K_{fl}(1.5K_s)x_{fl(max)}}{A_p A_s} = X_o \omega^2 \quad \text{(Modified flapper flow limit relation)} \quad (5)$$

Using the values of  $A_p$ ,  $A_s$ ,  $P_s$ ,  $Q_r$ ,  $K_{fl}$ ,  $K_s$ ,  $x_{fl,max}$  and  $M$  given in the list of symbols in the appendix the limits given by equations (1) to (5) can be calculated. The limit lines for the bypass valve system are shown in figure 6. This is a plot of actuator displacement  $X_o$  against frequency  $\omega$ . The lines on figure 6 show that, for piston displacements above 0.15 inch (0.38 cm) zero-to-peak, the bypass valve system performance is limited by the piston velocity limit relation. And for piston displacements below 0.15 inch (0.38 cm), the system performance is limited by the flapper flow limit relation.

## LINEAR SERVOSYSTEM OPERATION AND PERFORMANCE

### Derivation of Linearized Servosystem Transfer Function Model

Figure 7 is the resulting block diagram of the system shown in figure 5. The transfer function representation for each block shown in the block diagram of figure 7 is presented in this section.

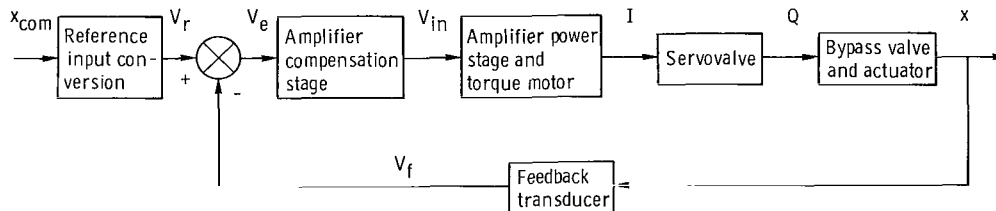

Figure 7. - General block diagram of inlet bypass valve servosystem.

Bypass valve actuator and servovalve output transfer function  $\frac{x}{Q}$  (S). - Referring to figure 5, the summation of forces on the actuator gives

$$(P_1 - P_2)A_p = M\ddot{x} + B\dot{x} \quad (6)$$

From conservation of mass,  $Q_1$  and  $Q_2$  become

$$Q_1 = k\dot{P}_1 + A_p\dot{x} \quad (7)$$

$$Q_2 = -k\dot{P}_2 + A_p\dot{x} \quad (8)$$

For centered operation,  $Q_1 = Q_2 = Q$ . Adding equations (7) and (8) and letting  $P_1 - P_2 = \Delta P_c$  gives

$$k \Delta \dot{P}_c + 2A_p \dot{x} = 2Q \quad (9)$$

Equation (6) becomes

$$A_p \Delta P_c = M\ddot{x} + B\dot{x} \quad (10)$$

Substituting equation (10) into equation (9); neglecting initial conditions; using  $S = d/dt$ , where  $S$  is the Laplace operator; and rearranging gives

$$\frac{x}{Q}(S) = \frac{\frac{1}{A_p}}{S \left( \frac{kM}{2A_p^2} S^2 + \frac{kB}{2A_p^2} S + 1 \right)} \quad (11)$$

The effective capacitance is

$$k = \frac{V_o}{\beta}$$

where  $V_o = \frac{1}{2} V_{\text{cylinder}} + V_{\text{lines}}$  on one side. Substituting values from the symbol list in the appendix into equation (11) gives

$$\frac{x}{Q}(S) = \frac{3.02}{S \left[ \left( \frac{S}{1929} \right)^2 + \frac{S}{5843} + 1 \right]} \text{ in./in.}^3/\text{sec} = \frac{0.468}{S \left[ \left( \frac{S}{1929} \right)^2 + \frac{S}{5843} + 1 \right]} \text{ cm/cm}^3/\text{sec} \quad (12)$$

Servo valve flow transfer function  $\frac{Q}{I}(S)$ . - The derivation is presented in detail in reference 11 and is restated briefly here. Figure 8 shows the simplified servo valve

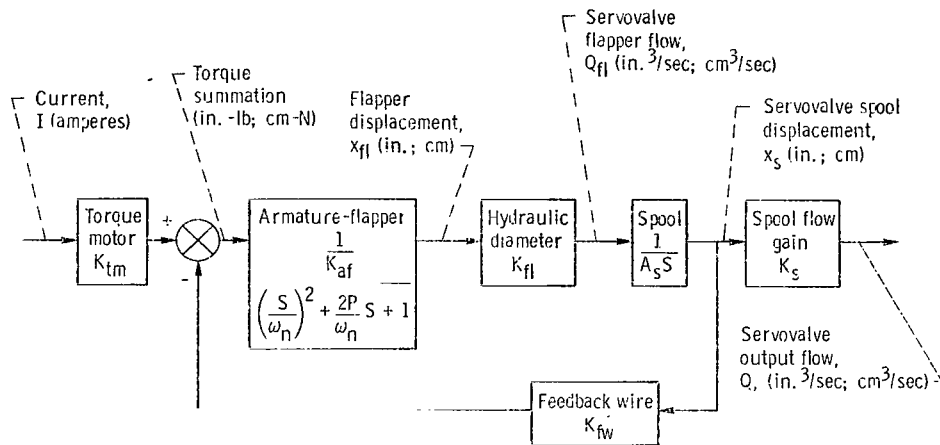

Figure 8. - Simplified servovalve block diagram.

block diagram. Substituting the values from the symbol list into the transfer functions shown in figure 8 and factoring the resulting equation gives the following servovalve-flow-to-current relation:

$$\frac{Q}{I}(S) = \left[ \frac{1557}{\left(\frac{S}{762} + 1\right) \left(\frac{S}{4322}\right)^2 + \frac{S}{5732} + 1} \right] \text{ in.}^3/\text{sec/A}$$

$$= \left[ \frac{25\,524}{\left(\frac{S}{762} + 1\right) \left(\frac{S}{4322}\right)^2 + \frac{S}{5732} + 1} \right] \text{ cm}^3/\text{sec/A} \quad (13)$$

Servovalve torque motor and servoamplifier output transfer function  $\frac{I}{V_{in}}(S)$ .

Figure 9 shows the simplified block diagram of the power amplifier coupled to the

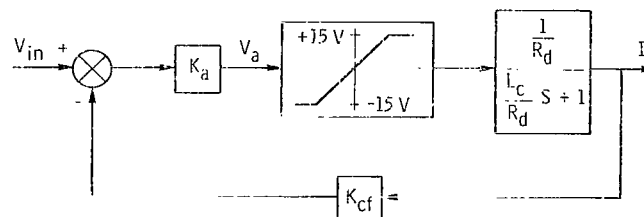

Figure 9. - Coil and power amplifier simplified block diagram.

servovalve torque motor. It was taken from reference 9 which presents a much more detailed discussion of the complete amplifier. The following equation form was obtained from the block diagram of figure 9 and was used for the  $\frac{I}{V_{in}}(S)$  relation:

$$\frac{I}{V_{in}}(S) = \frac{K}{\frac{S}{b} + 1} \quad (14)$$

In the real system the frequency response of torque motor current  $I$  to input voltage  $V_{in}$  is dependent on the current amplitude. The larger the current, the larger the effective time constant  $1/b$  of the torque motor and power amplifier combination. A conservative time constant resulted in the following numerical values for equation (14):

$$\frac{I}{V_{in}}(S) = \frac{0.00441}{\frac{S}{2000} + 1} \text{ A/V} \quad (15)$$

Compensation circuit transfer function  $\frac{V_{in}}{V_e}(S)$ . - The servoamplifier used had

three stages. The first stage was used for signal summing; it also had an adjustable gain. The second stage was used for dynamic compensation. And the third stage was the power stage which also received the dither input. Further information about this servoamplifier, including circuit diagrams, transfer functions, and experimental performance, is presented in reference 9.

A lead-lag-type compensation was chosen, based on a root-locus study of the open-loop system. This study is presented in the following section. The transfer function is

$$\frac{V_{in}}{V_e}(S) = \frac{K \left( \frac{S}{1010} + 1 \right)}{\frac{S}{3030} + 1} \quad (16)$$

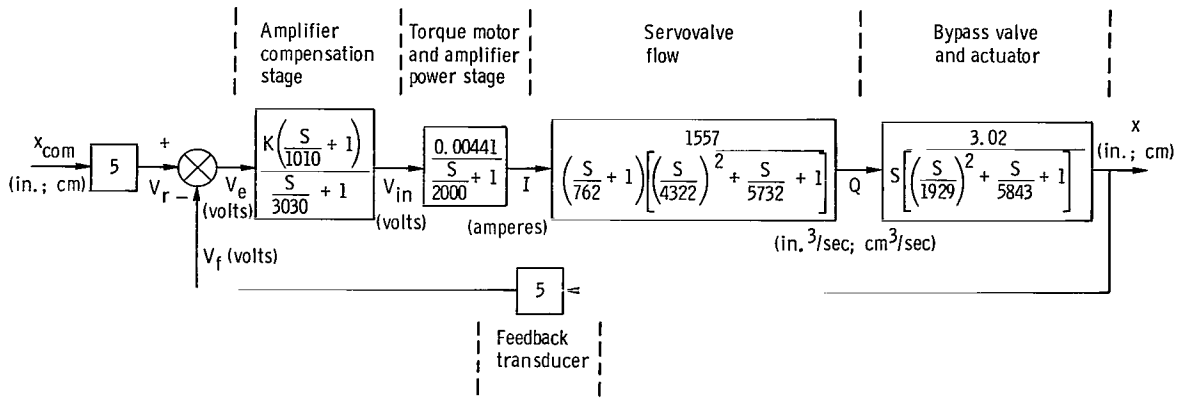

Figure 10. - Block diagram of system.

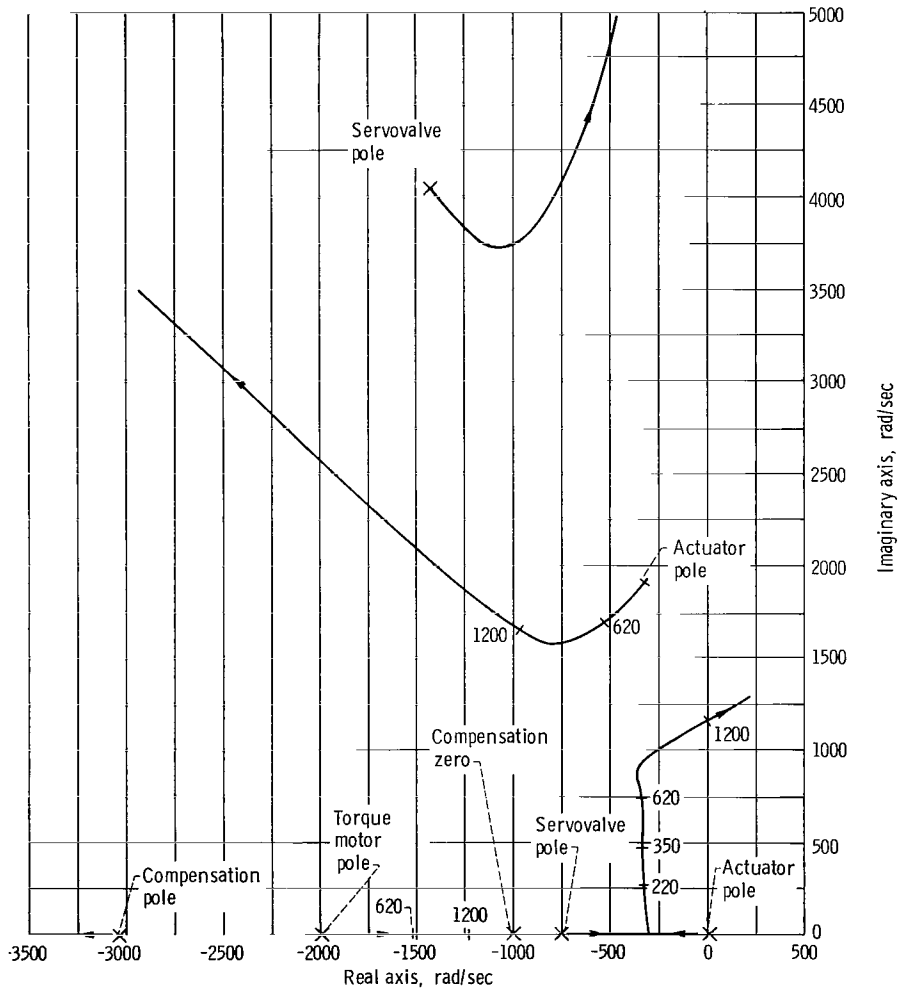

Figure 11. - Root-locus of inlet bypass valve position servosystem.

Feedback transducer transfer function. - The feedback transducer was represented by a constant of 5 volts per inch and contributes no dynamics in the area of interest

$$\frac{V_f}{x}(s) = 5 \text{ V/in.} = 1.97 \text{ V/cm} \quad (17)$$

The complete block diagram with all the transfer functions is shown in figure 10. The only value not specified is the gain setting of the servoamplifier. The next section will show how an acceptable setting was achieved.

### Servosystem Analytical Design

A root-locus plot of closed-loop performance of the servosystem is presented in figure 11. In the diagram, the poles and zeros which originate from the components of the servoloop are indicated. The system loop gains are shown parametrically along the loci up to the value of gain that makes the servosystem unstable, namely 1200. Loci which show no numerical values do not move from their zero gain locations until the loop gain has been increased above 1200.

The loci originating from the  $1/S$  actuator-load pole and the servovalve flow pole at 762 radians per second are the first loci to indicate system instability.

### Comparison Between Experimental and Analytical Results

The complete servosystem using the lead-lag compensation of equation (16) and a loop gain of 350 was run experimentally at a peak-to-peak amplitude of 0.140 inch (0.356 cm). This corresponds to 14 percent of full bypass valve area. In figure 12 a comparison is presented between the experimental servosystem response, the analytical response obtained from the transfer function analysis, and the saturation limit lines.

The analytical and experimental amplitude responses agree well to about 130 hertz. At this point the servovalve flapper flow limit predominates, as expected. For the experimental curve, the -3-decibel point (0.707 amplitude ratio) is at approximately 110 hertz, while the phase angle (fig. 12(b)) is approximately a  $160^\circ$  lag. For smaller amplitudes the linear closed-loop dynamics predominates the servosystem response while for larger amplitudes the servovalve flapper flow and piston velocity saturation limits determine the responses. In using the bypass valves as an inlet perturbing device, it was found that significant inlet pressure and flow perturbations could be induced by operating all six bypass valves at about one-half of the amplitude shown in figure 12.



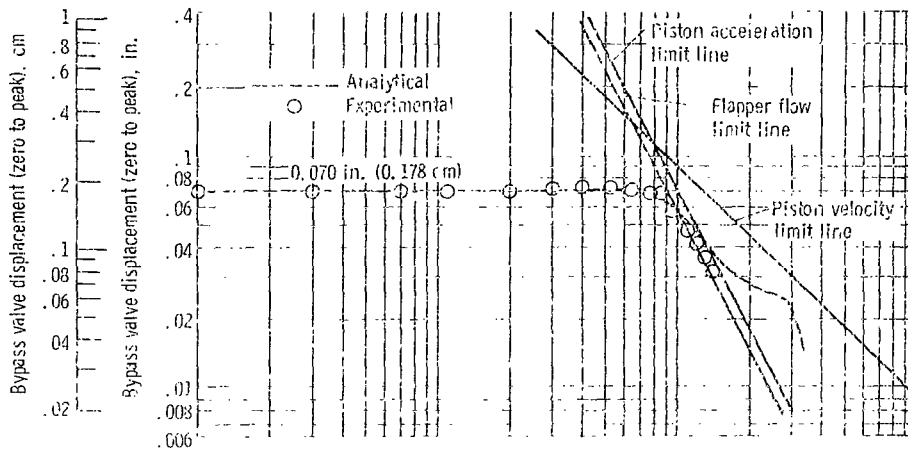

(a) Amplitude ratio.

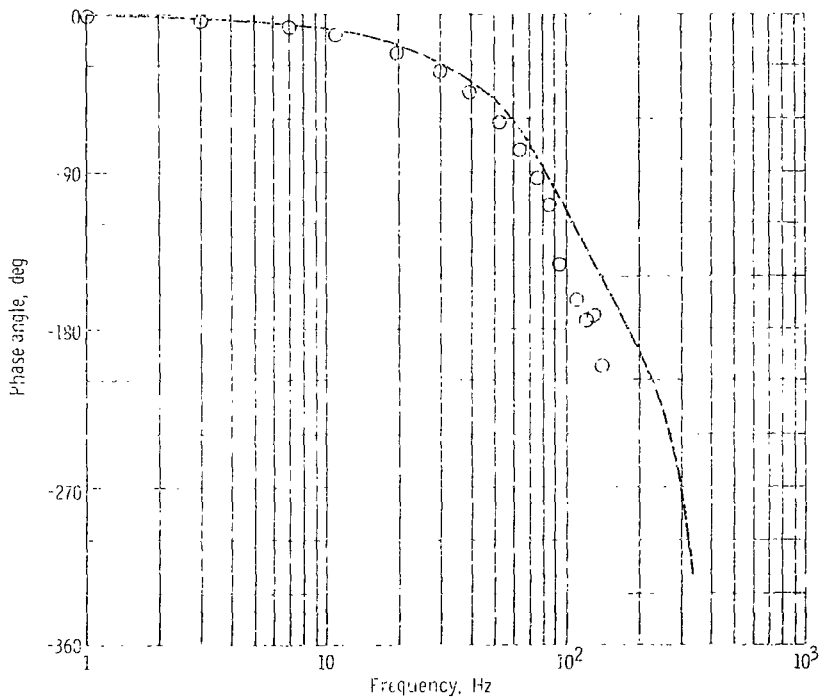

(b) Phase angle plot

Figure 12. - Analytical and experimental inlet bypass valve position response. Supply pressure, 2000 psi (137.9 N/cm<sup>2</sup>); loop gain, 350.

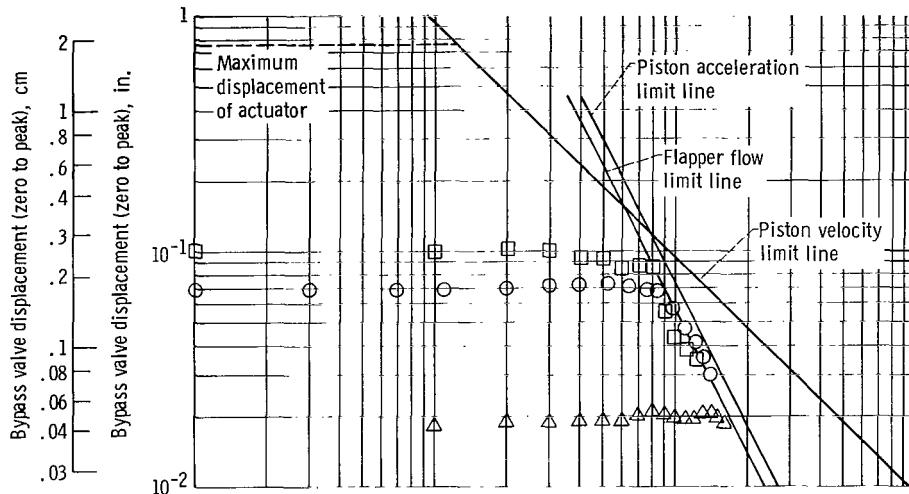

(a) Amplitude ratio.

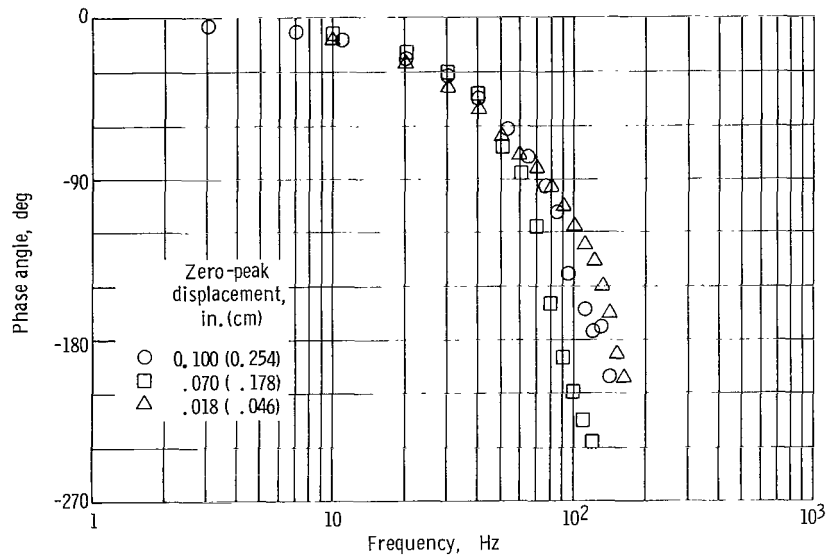

(b) Phase angle plot.

Figure 13. - Experimental position response of inlet bypass valve servosystem to three different amplitudes, demonstrating system performance limitation by servovalve flapper flow limit. Supply pressure, 2000 psi (1379 N/cm<sup>2</sup>); loop gain, 350.

Figure 13 shows the position response of the bypass valve servosystem for three different amplitudes. It shows that the system response is limited by the servovalve flapper flow limit for the two larger amplitudes used.

## RECOMMENDATIONS FOR IMPROVED MECHANICAL RELIABILITY

During the lengthy experimental test programs, a number of mechanical reliability problems were experienced with the high-performance inlet bypass valve system. Most of these problems are consequences of the cyclic forces created by the actuator and the bypass valve during repeated frequency response tests. Some of the more prevalent problem areas are

- (1) Fatigue failure of the mechanical linkage between the actuator and valve plate
- (2) Excessive backlash of attachment linkages
- (3) Inadequate bearing life on the sliding portions of the bypass valve
- (4) Unacceptable oscillations due to the connection of the feedback transducer to the valve body having backlash coupling to the actuator
- (5) Wear of actuator attachment points
- (6) Destruction of specific locations on contacting-type feedback transducers due to frequency response testing in this area

Elimination or minimization of these problems requires the mechanical designer to give careful consideration to the special problems of these high-performance servo-systems. The long cyclic life and zero backlash requirements can be met by the use of flexures in the place of linkages, overdesigned attachments, and noncontacting feedback transducers.

Operating experience has been obtained with another slotted-valve configuration (ref. 12) designed subsequent to the application reported herein. In this design, linkage backlash and fatigue failure problems were eliminated by taking the cyclic life requirements carefully into consideration during the design.

## CONCLUDING REMARKS

A slotted-plate valve and electrohydraulic servosystem was designed for use with a supersonic inlet. This design, as well as the application of a simplified technique for calculating servosystem saturation limits, is presented. A linearized transfer function block diagram for the bypass valve servosystem is derived, and system compensation is determined by means of the root-locus technique. A comparison between experimental and analytical responses illustrated good agreement. For controls investigations, the

bypass doors were within  $\pm 3$  decibels from 0 to 110 hertz for a peak-to-peak stroke amplitude that gave 14 percent of full bypass valve area. These capabilities were utilized significantly in several dynamics and controls investigations (refs. 4 and 8). By the use of the design techniques illustrated herein, the servosystem designer can build similar high-response electrohydraulic servovalve-actuated control devices with acceptable dynamic performance.

Lewis Research Center,  
National Aeronautics and Space Administration,  
Cleveland, Ohio, July 28, 1970,  
720-03.

## APPENDIX - SYMBOLS

$A_p$	actuator piston area, 0.331 in. <sup>2</sup> (2.14 cm <sup>2</sup> )	$K_s$	servovalve spool displacement to servovalve output flow gain, 840 in. <sup>3</sup> /sec/in. (5419 cm <sup>3</sup> /sec/cm) using 2000-psi (1379-N/cm <sup>2</sup> ) supply
$A_s$	servovalve spool end area, 0.026 in. <sup>2</sup> (0.168 cm <sup>2</sup> )	$K_{tm}$	servovalve torque motor current to torque gain, 25 in.-lb/in. (111 cm-N/cm)
a	inside area of lines connecting actuator and servovalve, 0.0254 in. <sup>2</sup> (0.164 cm <sup>2</sup> )	k	effective actuator and servovalve capacitance, $V_o/\beta$ , 3.75×10 <sup>-6</sup> in. <sup>3</sup> /psi (89.1×10 <sup>-6</sup> cm <sup>3</sup> /N/cm <sup>2</sup> )
B	damping coefficient, 10 lb-sec/in. (17.5 N-sec/cm)	$L_c$	effective torque motor coil inductance, 2.65 H
b	constant, 1/sec	l	length of lines connecting actuator and servovalve, 5.0 in. (12.7 cm)
d	inside diameter of lines connecting actuator and servovalve, 0.18 in. (0.46 cm)	M	load mass, 1.57×10 <sup>-2</sup> lb-sec <sup>2</sup> /in. (2.75×10 <sup>-2</sup> N-sec <sup>2</sup> /cm)
I	torque motor current, A	$\Delta P_c$	net pressure acting across actuator piston, $P_1 - P_2$ , psi (N/cm <sup>2</sup> )
K	amplifier gain, V/V	$P_s$	hydraulic supply pressure, 2000 psi (1379 N/cm <sup>2</sup> )
$K_a$	power amplifier voltage gain, 50 V/V	$P_1, P_2$	servovalve control port pressures, psi (N/cm <sup>2</sup> )
$K_{af}$	servovalve armature-flapper torque to flapper displacement gain, 93 in.-lb/in. (414 cm-N/cm)	Q	servovalve output flow, in. <sup>3</sup> /sec (cm <sup>3</sup> /sec)
$K_{cf}$	current feedback gain, 200 V/A	$Q_{fl}$	servovalve flapper flow, in. <sup>3</sup> /sec (cm <sup>3</sup> /sec)
$K_{fl}$	servovalve flapper displacement to flapper flow gain, 122 in. <sup>3</sup> /sec/in. (787 cm <sup>3</sup> /sec/cm) using 2000-psi (1379-N/cm <sup>2</sup> ) supply	$Q_r$	manufacturers servovalve rated flow, 15.4 in. <sup>3</sup> /sec (252 cm <sup>3</sup> /sec)
$K_{fw}$	servovalve feedback wire displacement to torque gain, 13.5 in.-lb/in. (60 cm-N/cm)		

$Q_1, Q_2$	servovalve control port flows, in. <sup>3</sup> /sec (cm <sup>3</sup> /sec)	$x$	actuator displacement, in. (cm)
$R_d$	resistance, 1350 V/A	$x_{com}$	commanded actuator displacement, in. (cm)
$S$	Laplace operator, 1/sec	$x_{fl}$	flapper displacement, in. (cm)
$V_a$	power amplifier voltage, A	$x_{fl, max}$	maximum flapper displacement, 0.0012 in. (0.00305 cm)
$V_{cylinder}$	piston actuator volume, 0.497 in. <sup>3</sup> (8.14 cm <sup>3</sup> )	$x_{max}$	maximum displacement of actuator, 1.50 in. (3.81 cm)
$V_e$	servoamplifier error voltage, V	$x_s$	servovalve spool displacement, in. (cm)
$V_f$	transducer feedback voltage, V	$\beta$	hydraulic fluid bulk modulus, 10 <sup>5</sup> psi (69×10 <sup>3</sup> N/cm <sup>2</sup> )
$V_{in}$	input voltage to power amplifier, V	$\rho$	servovalve armature-flapper damping ratio, 0.4
$V_{line}$	volume of line between actuator and servovalve, 0.127 in. <sup>3</sup> (2.08 cm <sup>3</sup> )	$\omega$	frequency, rad/sec
$V_o$	volume of oil under compression (one-half cylinder volume + volume of lines on one side between cylinder and servovalve), 0.375 in. <sup>3</sup> (6.15 cm <sup>3</sup> )	$\omega_n$	servovalve natural frequency, 4587 rad/sec
$V_r$	command reference voltage, V	Superscript:	
$X_o$	zero-to-peak amplitude of sinusoidal piston displacement, in. (cm)	( $\dot{\quad}$ )	time derivative of variable, d/dt

## REFERENCES

1. Cubbison, Robert W.; Meleason, Edward T.; and Johnson, David F.: Effect of Porous Bleed in a High-Performance Axisymmetric, Mixed-Compression Inlet at Mach 2.50. NASA TM X-1692, 1968.
2. Cubbison, Robert W.; Meleason, Edward T.; and Johnson, David F.: Performance Characteristics from Mach 2.58 to 1.98 of an Axisymmetric Mixed-Compression Inlet System with 60-Percent Internal Contraction. NASA TM X-1739, 1969.
3. Willoh, Ross G.: A Mathematical Analysis of Supersonic Inlet Dynamics. NASA TN D-4969, 1968.
4. Crosby, Michael J.; Neiner, George H.; and Cole, Gary L.: Restart and High Response Terminal Shock Control for an Axisymmetric Mixed-Compression Inlet with 60-Percent Internal Contraction. NASA TM X-1792, 1969.
5. Cole, Gary L.; Neiner, George H.; and Crosby, Michael J.: An Automatic Restart Control System for an Axisymmetric Mixed-Compression Inlet. NASA TN D-5590, 1969.
6. Cole, Gary L.; Neiner, George H.; and Wallhagen, Robert E.: A Coupled Supersonic Inlet-Engine Control Using Overboard Bypass Doors and Engine Speed to Control Normal Shock Position. NASA TN D-6019, 1970.
7. Paulovich, Francis J.; Neiner, George H.; and Hagedorn, Ralph E.: A Supersonic Inlet-Engine Control Using Engine Speed as a Primary Variable for Controlling Normal Shock Position. NASA TN D-6021, 1970.
8. Wasserbauer, Joseph: Dynamic Responses of a Mach 2.5 Axisymmetric Inlet with Engine or Cold Pipe and Utilizing 60 Percent Supersonic Internal Area Contraction. NASA TN D-5338, 1969.
9. Zeller, John R.: Design and Analysis of a Modular Servoamplifier for Fast-Response Electrohydraulic Control Systems. NASA TN D-4898, 1968.
10. Zeller, John R.: Analysis of Dynamic Performance Limitations of Fast Response (150 to 200 Hz) Electrohydraulic Servos. NASA TN D-5388, 1969.
11. Thayer, W. J.: Transfer Functions for Moog Servovalves. Tech. Bull. 103, Moog Servocontrols, Inc., Jan. 1965.
12. Baumbick, Robert J.: Device for Producing Dynamic Distortion Patterns at Inlets of Air-Breathing Engines. NASA TM X-2026, 1970.

NATIONAL AERONAUTICS AND SPACE ADMINISTRATION  
WASHINGTON, D. C. 20546  
OFFICIAL BUSINESS

FIRST CLASS MAIL



POSTAGE AND FEES PAID  
NATIONAL AERONAUTICS AND  
SPACE ADMINISTRATION

01U 001 28 51 3DS 70286 00903  
AIR FORCE WEAPONS LABORATORY /WLOL/  
KIRTLAND AFB, NEW MEXICO 87117

ATT E. LOU BOWMAN, CHIEF, TECH. LIBRARY

POSTMASTER: If Undeliverable (Section 158  
Postal Manual) Do Not Return

*"The aeronautical and space activities of the United States shall be conducted so as to contribute . . . to the expansion of human knowledge of phenomena in the atmosphere and space. The Administration shall provide for the widest practicable and appropriate dissemination of information concerning its activities and the results thereof."*

—NATIONAL AERONAUTICS AND SPACE ACT OF 1958

## NASA SCIENTIFIC AND TECHNICAL PUBLICATIONS

**TECHNICAL REPORTS:** Scientific and technical information considered important, complete, and a lasting contribution to existing knowledge.

**TECHNICAL NOTES:** Information less broad in scope but nevertheless of importance as a contribution to existing knowledge.

**TECHNICAL MEMORANDUMS:** Information receiving limited distribution because of preliminary data, security classification, or other reasons.

**CONTRACTOR REPORTS:** Scientific and technical information generated under a NASA contract or grant and considered an important contribution to existing knowledge.

**TECHNICAL TRANSLATIONS:** Information published in a foreign language considered to merit NASA distribution in English.

**SPECIAL PUBLICATIONS:** Information derived from or of value to NASA activities. Publications include conference proceedings, monographs, data compilations, handbooks, sourcebooks, and special bibliographies.

**TECHNOLOGY UTILIZATION PUBLICATIONS:** Information on technology used by NASA that may be of particular interest in commercial and other non-aerospace applications. Publications include Tech Briefs, Technology Utilization Reports and Notes, and Technology Surveys.

*Details on the availability of these publications may be obtained from:*

SCIENTIFIC AND TECHNICAL INFORMATION DIVISION  
NATIONAL AERONAUTICS AND SPACE ADMINISTRATION  
Washington, D.C. 20546