

Differentiation Criteria Study for Continuous Stirred Tank Reactor and Plug flow Reactor¹

D. D.-W. Tsai and P. H. Chen

Department of Soil and Water Conservation, National Chung-Hsing University, Taichung, Taiwan

e-mail: hlchen@dragon.nchu.edu.tw

Received January 21, 2011

Abstract—All reactors in reality are not ideal plug flow reactor (PFR) or ideal continuous stirred tank reactor (CSTR). They are difficult to differentiate. This study was to investigate the reactor analysis of PFR and CSTR through tracer response curves, residence time distributions (RTD) and several hydraulic performance indexes. We set up the differentiated value of each index. The tracer response curve showed that our lab-scale CSTR was close to ideal CSTR and got 99.9% recovery. In the RTD curves, the results could significantly recognize the PFR nature of high rate pond (HRP). With hydraulic performance indexes study, every selected index demonstrated that the studied HRP was closer to PFR than the studied CSTR. Based on the lab-scale study results, this study established the cutting point between the PFR and CSTR in each index; we were looking through the different types of reactors in literature and we confirmed the criteria with all literature reactors with the “graphic method”. The method helped us to establish those important values to help us to differentiate the reactor types in practice and to understand the designs better.

DOI: 10.1134/S0040579513060122

INTRODUCTION

High rate pond (HRP) was a remarkable design which was developed by W. Oswald in Richmond field station, U.C. Berkeley. Oswald tried to mimic the ecosystem mechanisms to optimize the reactor efficiency. Currently HRP has played a critical role for lots of applications in field especially on algae production, wastewater treatment, nutrition, food, pharmaceutical material, aquaculture, biotech, bio-fuel, etc.

The original design of HRP was tried to imitate plug flow reactor (PFR) in practice [1]. However, in reality, most of reactors are not ideal, mixed between ideal PFR and ideal continuous stirred tank reactor (CSTR) in a certain degree. The differentiation of reactor type was very difficult and there was only one reference index in the literature: Morrill dispersion index (MDI) which was induced from the engineering field reactor designs by Metcalf and Eddy Inc. [2]. The reactor differentiation was very significant to help the evaluation of reactor designs and performances. Consequently, the primary objective of this research was to focus on reactor analysis study such as: tracer response curves, residence time distributions (RTD), hydraulic performance indexes, etc. and to develop a cut off value of the indexes to differentiate a reactor between PFR and CSTR in reality.

EXPERIMENTAL

The research methodology is illustrated in Fig. 1. The bench scale HRP and lab-scale CSTR reactor were set up in the Sustainable Resources and Sustainable Engineering research lab (SRSE-LAB), department of soil and water conservation, National Chung-Hsing University, Taichung, Taiwan. The bench HRP was taken as a typical PFR [1] and the bench CSTR could be treated as the conventional standard CSTR reactor [3–6]. The lab-scale HRP design is shown in Fig. 2. Both reactors operated at 4 h detention time with spiking. Detention time is the theoretical time required for an amount of water to pass through a reactor at a given rate of flow and calculated as reactor volume divided by volumetric flow rate [2]. All other operational factors are listed in table. The reactor analysis of the tracer study was adopted and the results including tracer response curves, RTD and the most popular 5 hydraulic performance indexes were studied as depicted in Fig. 1.

Based on the bench CSTR and HRP, we set up the proper cut-point for each index to differentiate the reactor. For the confirmation and verification, the reactor performance studies in literature were adopted to calculate those indexes with the “graphic method” if the index values were not obtainable. The basic requirement for the calculation was tracer response curve and we drew several lines in fixed intervals of the curve to get tracer concentration at specific time we wanted and then to calculate the specific index from the paper. This was so-called the “graphic method”.

¹ The article is published in the original.

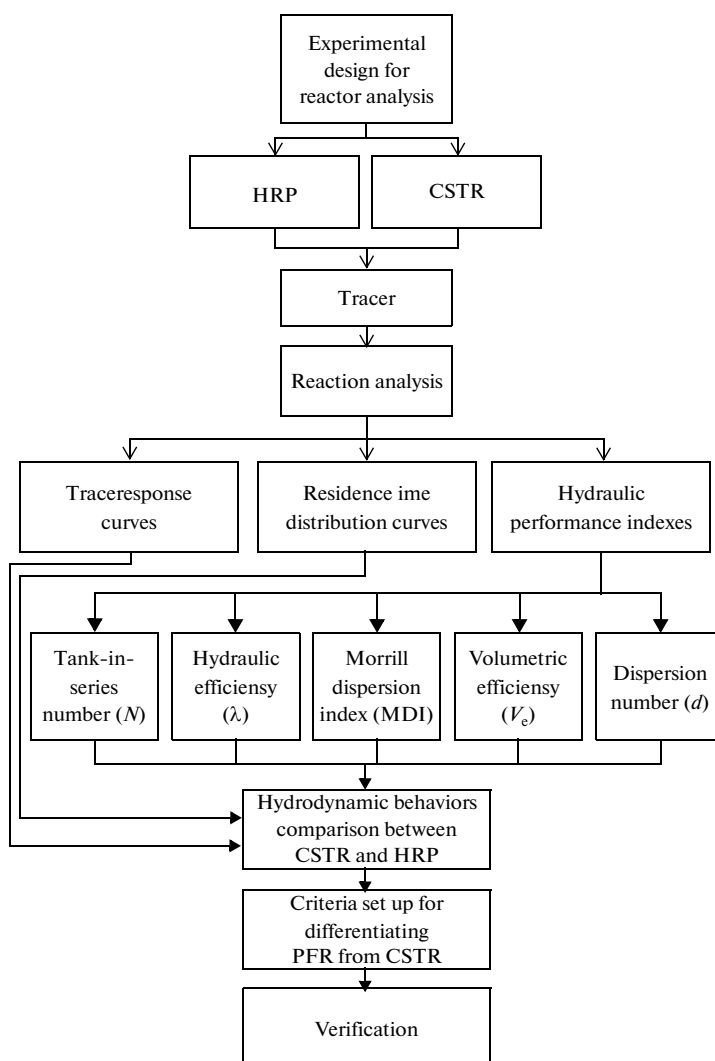

Fig. 1. Flow chart of methodology in this study.

After collecting the data of those reactor performances in each index from literature which was possibly found, we checked and verified the cut-point values by those cases.

RESULTS AND DISCUSSION

Tracer response curves. The tracer response curve of the CSTR is shown in Fig. 3. Mean retention time (τ_{mean}) was equal to 258 min and was about same with theoretical retention time (τ) of 240 min. Lab CSTR is a “closed reactor” under a closed boundary condition [7] therefore τ_{mean} should be equal to τ [8]. In Fig. 3, the CSTR was very close to ideal CSTR. The major reason was the limitation of the measure interval which made the CSTR’s peak appeared in the first measurement. Theoretically, the peak should be close to ideal CSTR.

The duration of this experiment was 735 min (3.06τ) and the final conductivity was 0.181 mS/cm.

For RTD studies, three retention time was needed to obtain a steady state [9, 10]. And because of the background conductivity of tap-water of 0.110 mS/cm, the recovery rate was calculated as 99.9% and the result was excellent. The HRP had a longer τ_{mean} of 292 min than τ (240 min) and a reasonable good recovery rate of 92.5%, better than the only literature data, 91 and 92% [11]. Because of the special designs of inlet/outlet, paddle wheel and retention wall in HRP as in Fig. 2, HRP was formed the recirculation flow; would make suspensions flow with recirculation current and could not make the recirculation flow out completely at each run. Consequently, those designs caused an extended retention time and were the possible reasons why HRP had longer τ_{mean} .

RTD curves. The RTD (E) curves of the CSTR, the HRP and ideal reactors are shown in Fig. 4. Since E curve standardized the area under the tracer response curve to 1 [2], we could possibly make a comparison among the different reactors. The CSTR’s and the

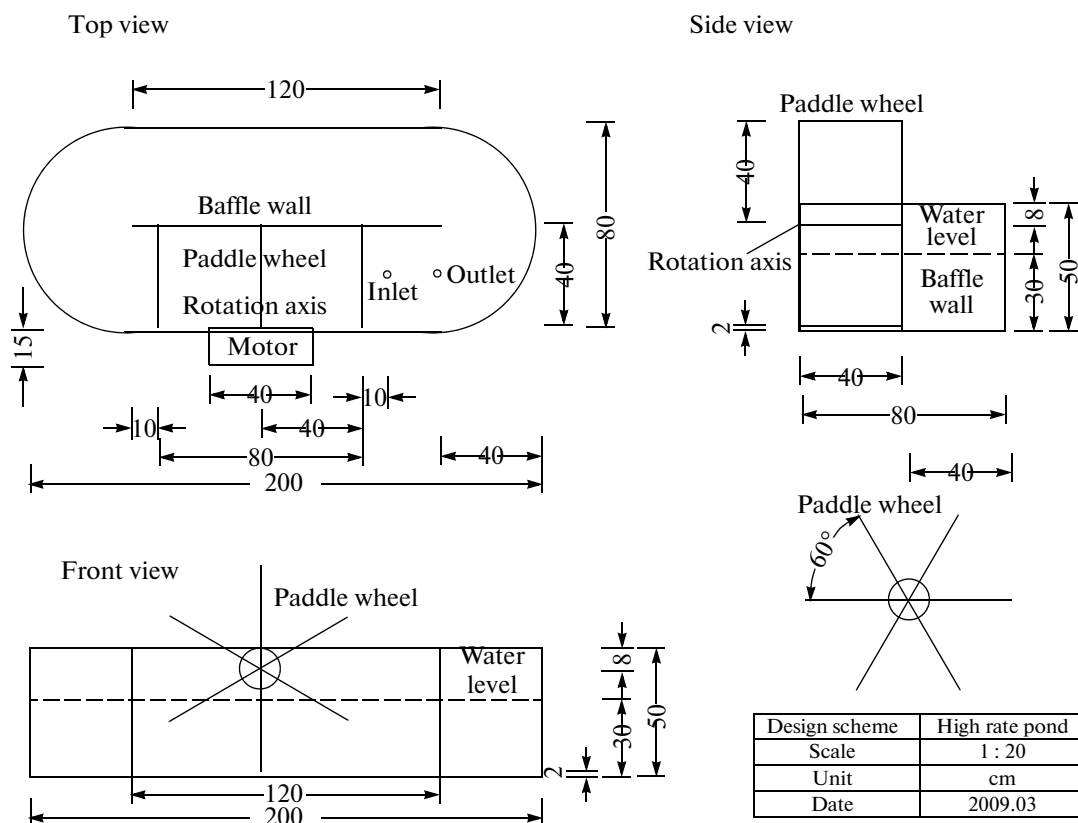

Fig. 2. HRP design scheme.

HRP's curves exhibited that the hydrodynamic behaviors were between ideal CSTR and PFR. Theoretically the homogeneity of the CSTR reactor must be better than HRPs'. For this reason the peak of CSTR reactors would be sooner and higher than HRPs'. Both the peaks of the studied CSTR and the HRP showed in the same time at the first measurement since both the studied intervals were set as 15 min. However, it was

clear that the CSTR was much closer to ideal CSTR than the HRP as shown in following. The peak of CSTR curve whose E of 0.0032 was obviously close to ideal CSTR value of 0.0042 and HRP of 0.0027 was a little off away from ideal CSTR. In short, the HRP exhibited more PFR natures than CSTR in lab.

The E accumulated curves (so-called F curves) could be illustrated as Fig. 5. We calculated the ideal

List of operational factors

Operational factor	HRP	CSTR
Scale	Lab	Lab
Detention time	4 h	4 h
Reactor design	Paddle wheel with recirculation	4 L up-flow flask
Water level	15 cm	—
Water volume	199 L	4 L
Inflow speed	820 mL/min	16.8 mL/min
Tracer	NaCl	NaCl
Inflow type	Spike	Spike
Mixing speed (surface speed)	10 cm/s	Magnetic mixer
Effluent measure interval	15 min	15 min

CSTR mathematical equation ($C = C_0 e^{-t/\tau}$) [2] and we found 66% tracer out at τ (CSTR of 56.2% vs. ideal CSTR of 66% at τ). In this study, HRP 49.8% tracer out at was close to the theoretical value of “PFR in reality” of 50%. This further result proved the HRP exhibited more PFR characteristics than the studied CSTR.

Hydraulic performance indexes. Tanks-in-series number $N = t_{\text{mean}}^2/\sigma^2$ characterized the non-ideal flows through a series of equal-size ideal stirred tanks [12]. They were 1.71 and 1.90 in our study for CSTR and HRP respectively. The theoretical value of N is 1 for ideal CSTR [13] as shown in Fig. 6, N of 1.71 in our lab-scale CSTR was closer to ideal CSTR compared to HRP’s value of 1.90. Ouarghi et al. [11] concluded N of 2 as PFR for HRP in field, and our lab N of 1.90 was very close to this value. Consequently, we concluded our HRP was approaching to PFR than CSTR mathematically.

From the N values of 1.71 in our lab CSTR and 1.90 in our lab HRP, we set up the cut point as 1.8 to differentiate CSTR and PFR. In literature, the reported results of N in different types of reactors are shown in Fig. 6. All the reactors claimed as CSTR had N values less than 1.8, such as N was 0.95–1 for the lab-scale disinfection reactor [14]; $N = 1$ was studied in the field Orbal activated sludge system [15]; $N = 1.1$ –1.14 was in the lab scale and 1.6 in the pilot-scale membrane bioreactor (MBR) claimed by Wang et al. [16]. Even Wang’s design followed our criterion; conventionally membrane process was the PFR and why were the Wang et al.’s designs as CSTRs. We thought this was the reason to explain: they put a strong air aeration which was a mixer in fact, inside the reactors, consequently whole designs turned to be CSTRs. For another lots of CSTRs’ cases in literature without N values which were claimed by each author, we applied the “graphic method” to calculate the N index as follows: 1.26 in the bench-scale activated sludge process [17], 1.01–1.41 in lab electrochemical reactors [18], 0.64 in the pilot anaerobic fix-bed [19], 1.44 in the cyanidation tank [20], etc. All the available data confirmed the 1.8 setup.

All data of PFRs in literature were higher than 1.90 of our lab HRP. The activated sludge baffled reactor $N = 4$ which was claimed as PFR by Tizghadam et al. [21]. In a water treatment plant clearwell, N was in the range of 11.7–12.36 also as PFR apparently [22]. In the bench-scale anaerobic baffled reactor (ABR), N was estimated of 9–11 by Krishna et al. [23] and obviously it was PFR. All were larger than our setup point 1.8. So far, all CSTRs’ and PFRs values in literature obeyed our established criterion; the cut point of 1.8 in N could be the truth number to differentiate CSTR and PFR in reality.

Hydraulic efficiency $\lambda = e(1 - 1/N)$ is a metric that combined existing flow uniformity ($1 - 1/N$) and effective volume ratio (e) [24, 25]. In this study, $\lambda =$

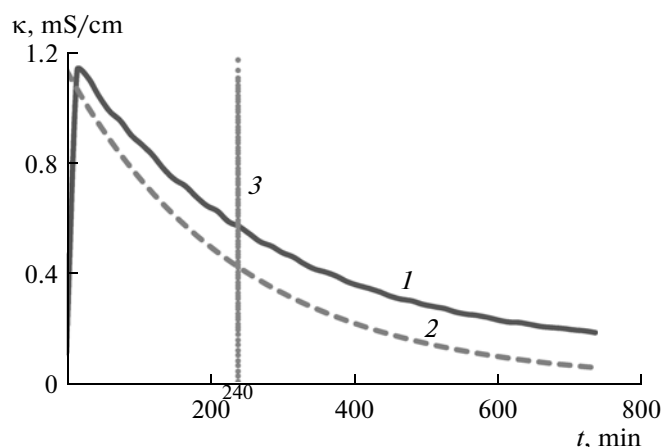

Fig. 3. Comparison of tracer response curves between the CSTR and ideal reactors: (1) CSTR; (2) ideal CSTR; (3) ideal PFR.

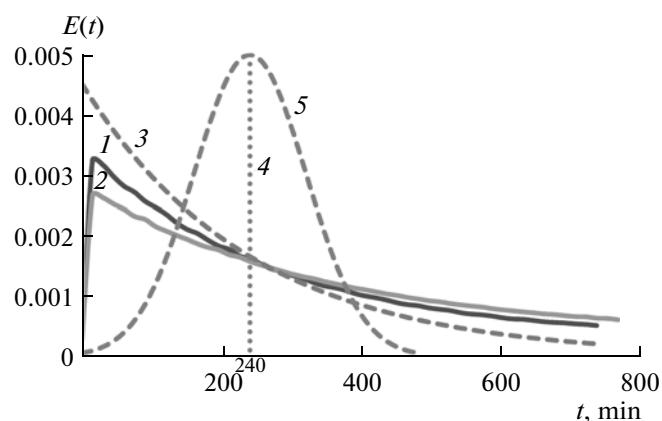

Fig. 4. Comparison of E curves among the CSTR, HRP and ideal reactors: (1) CSTR; (2) HRP; (3) ideal CSTR; (4) ideal PFR; (5) real PFR.

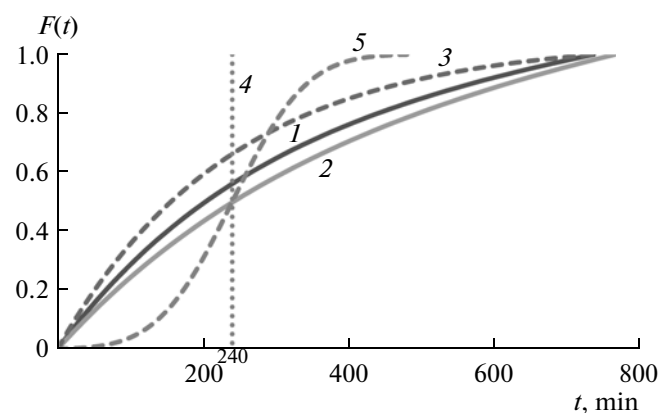

Fig. 5. Comparison of F curves among the CSTR, HRP and ideal reactors: (1) CSTR; (2) HRP; (3) ideal CSTR; (4) ideal PFR; (5) real PFR.

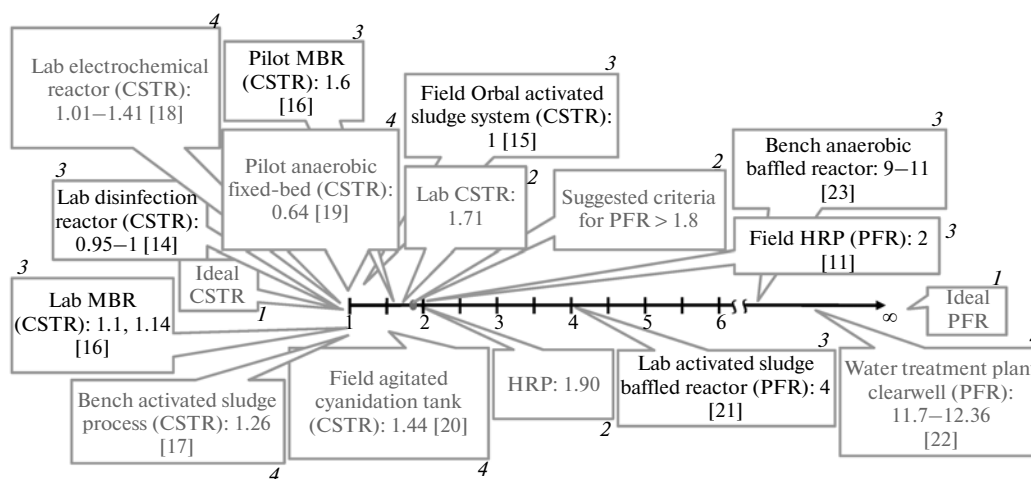

Fig. 6. Comparison of tanks-in-series number (N) among various types of reactors: (1) ideal values or official value for reactors in reality; (2) results of this study; (3) directly quoted from the literature; (4) calculated by graphic method from the literature by author.

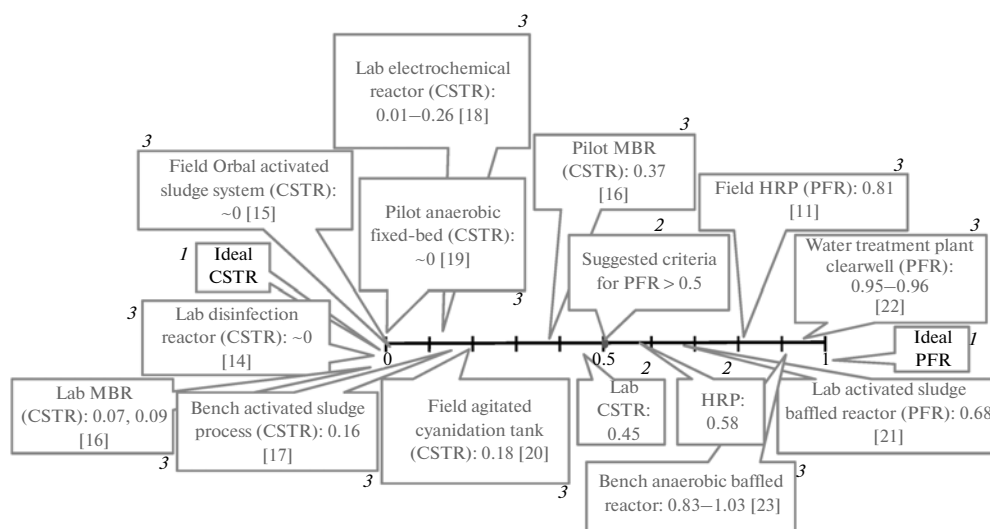

Fig. 7. Comparison of hydraulic efficiency (λ) among various types of reactors: (1) ideal values or official value for reactors in reality; (2) results of this study; (3) calculated by graphic method from the literature by author.

0.45 for the CSTR and $\lambda = 0.58$ for the HRP were computed in lab as shown in Fig. 7. For ideal CSTR and PFR, those indexes would be equal to 0 and 1 respectively. The distance from ideal PFR was 0.42 of the studied HRP which was closer than the distance of 0.58 of the CSTR to the ideal. As the result, the HRP was closer to PFR than CSTR here again and we could determine a criterion of 0.5 to categorize CSTR and PFR from our reactor study.

Hydraulic efficiency λ could be a practical index to sense the PFR natures in HRP. Examining through all CSTRs' values in literature were less than 0.45 of our CSTR data and all PFR literature were higher than 0.58 of our lab HRP just like in Fig. 7, the criterion of

0.5 could be the applicable value to classify all reactor designs into CSTR or PFR.

Morrill dispersion index (MDI) P_{90}/P_{10} which is an important index of dispersion behavior could be calculated by 10 and 90 percentile (P_{10} and P_{90}) from a log-probability plot of the time versus the cumulative percentage of passing tracer [26]. In our study of the CSTR and HRP, the results of MDI were 18.87 and 16.69 respectively in Fig. 8. Metcalf and Eddy Inc. [2] claimed ideal PFR equal to 1 and 22 for CSTR in field which was formed from the long time empirical data and did not include the bench scale design; the value of 18.87 for the studied CSTR was close to Metcalf and Eddy Inc.'s number. And the bench HRP 16.69 which was usually promoted by the high dispersion of strong

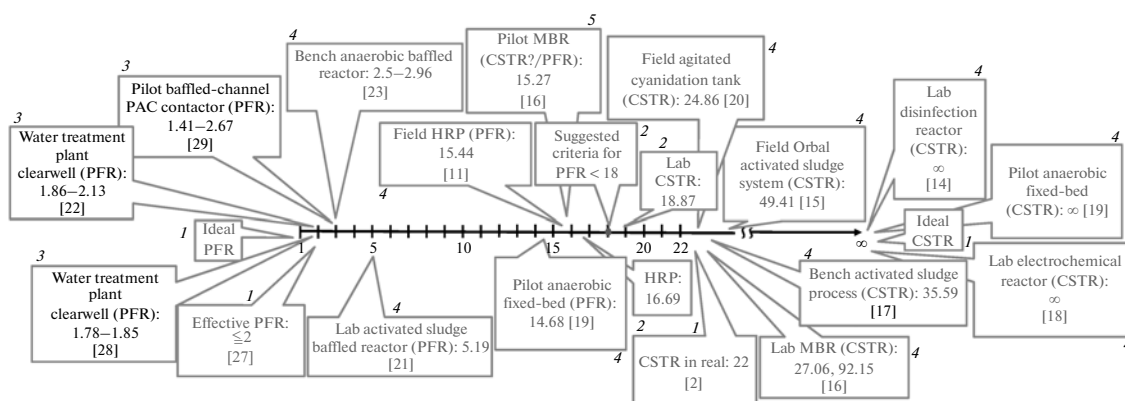

Fig. 8. Comparison of Morrill dispersion index (MDI) among various types of reactors: (1) ideal values or official value for reactors in reality; (2) results of this study; (3) directly quoted from the literature; (4) calculated by graphic method from the literature by author; (5) reactor did not follow the criterion we set.

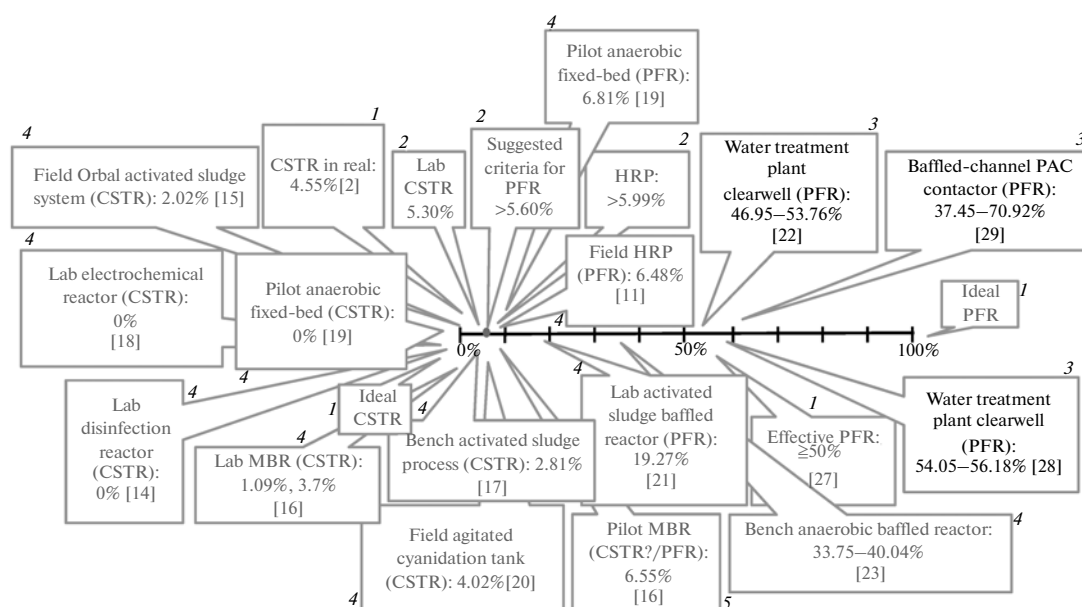

Fig. 9. Comparison of volumetric efficiency (V_e) among various types of reactors: (1) ideal values or official value for reactors in reality; (2) results of this study; (3) directly quoted from the literature; (4) calculated by graphic method from the literature by author; (5) reactor did not follow the criterion we set.

mixing in lab scale was lower than the study CSTR's 18.87 to differentiate the certain PFR natures in the HRP.

We authenticated 18 as a criterion to screen PFRs from CSTRs shown in Fig. 8. According to this value, the only exception that did not follow this rule in literature was 15.27 of the MBR in the pilot scale [16] which was claimed as CSTR by authors. But looking into the article of design and flow characteristics carefully, in the pilot-scale MBR the aerobic cell was separated from the membrane unit [16]; accordingly the membrane unit itself was a PFR process [30]. This only exception case still obeyed our rule even the author claimed it was CSTR by the special design incidentally.

The most important point here is that $P_{90}/P_{10} = 18$ was an adequate differentiator between CSTR and PFR. As mentioned before, $P_{90}/P_{10} = 22$ by Metcalf & Eddy Inc., all the CSTRs followed this rule and it performed reasonably well. However, this criterion is good for large scale rather than lab scale. The criterion we studied, $P_{90}/P_{10} = 18$, might possibly be a better standard for the reactors not only in field scale but also in lab scale.

In general, volumetric efficiency $V_e = P_{10}/P_{90}$ was used to estimate the proportion of the available reactor volume effectively [2]. In this study, HRP and CSTR, the values of V_e were 5.99 and 5.30% respectively. Calculated with theoretical MDI values and V_e will be

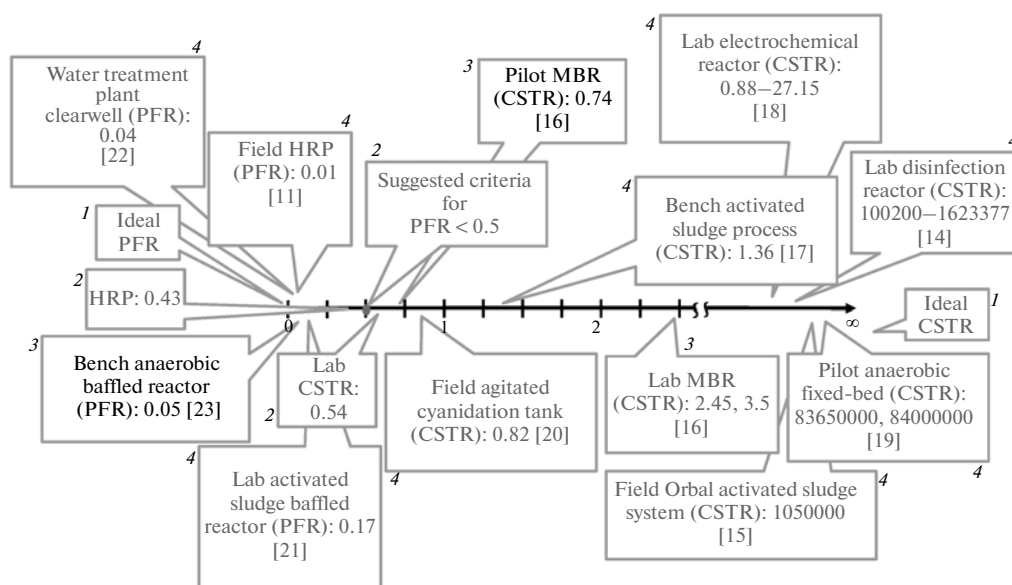

Fig. 10. Comparison of dispersion number (d) among various types of reactors: (1) ideal values or official value for reactors in reality; (2) results of this study; (3) directly quoted from the literature; (4) calculated by graphic method from the literature by author.

100% in ideal PFR. 5.99% seemed to be a low value for a HRP design in order to fulfill PFR purpose. This phenomenon could be explained by the lab scale flow characteristics and V_e index itself. Since there was the high dispersion in the HRP encouraged by a strong mixing with the enhancement of the recirculation/outlet effect, HRP would tend to lose more tracer in high concentration to make an early P_{10} , compared to the ideal PFR in Fig. 5. For the same reasons, the HRP would keep more tracer in the system to delay the P_{90} in the low concentration of tracer. The tendency of P_{10} came earlier to decrease the value t while P_{90} came later to increase the t value; this phenomenon would disguise the result into a smaller value and the studied HRP had a low V_e .

To establish the differentiation criteria, we compared the study HRP and CSTR to suggest 5.6% as a criterion of V_e . After calculating index values from the literature either by direct quotation from paper or estimation by the “graphic method”, all the results are showed in Fig. 9 and confirmed these data completely, we confidently instituted the criterion of $V_e = 5.6\%$ to separate the reactor type. The only exception of the MBR [16] was not a real CSTR as we discussed before.

Dispersion number $d = D/(uL)$ was proved as a sensitive index to screen PFR natures: 0.54 of the lab CSTR and 0.43 of HRP in our study. The index of d approaching 0 theoretically was an ideal PFR and approaching ∞ was an ideal CSTR [31]. For the distance comparison, the studied HRP was close to PFR in Fig. 10 and the figure also proved all the data among different types of reactors in literature obeyed and followed the determined criterion ($d = 0.5$).

CONCLUSIONS

It is very difficult to separate a reactor in reality between PFR and CSTR as we mentioned before. We cannot find any criteria except Metcalf and Eddy Inc.’s in literature which was for field only. This study discovered the true values of the five most popular reactor indexes to differentiate a reactor either in lab scale or in field scale: $N = 1.8$, $\lambda = 0.5$, $P_{90}/P_{10} = 18$, $V_e = 5.6\%$, $d = 0.5$ to help us to understand the reactors better.

NOTATION

C —concentration of the tracer in the reactor at time t , mg/L;
 C_0 —initial concentration of the tracer in the reactor, mg/L;
 D —axial dispersion coefficient, m^2/s ;
 $d = D/(uL)$ —dispersion number;
 E —residence time distribution function;
 e —effective volume ratio;
 F —fraction of the tracer in the exit stream;
 L —characteristic length, m;
 $N = t_{\text{mean}}^2/\sigma^2$ —tanks-in-series number;
 P_{10} —time at which 10% of the tracer has passed through the reactor, min;
 P_{90} —time at which 90% of the tracer has passed through the reactor, min;
 P_{90}/P_{10} —Morrill dispersion index;
 t —time, min;
 t_{peak} —time at which peak concentration of the tracer is observed, min;

u —fluid velocity, m/s;
 $V_e = P_{10}/P_{90}$ —volumetric efficiency;
 κ —conductivity, mS/cm;
 $\lambda = e(1 - 1/N) = t_{\text{peak}}/\tau$ —hydraulic efficiency;
 σ^2 —variance of the response curve, min²;
 τ —theoretical retention time, min;
 τ_{mean} —mean retention time, min.

REFERENCES

- Jupsin, H., Praet, E., and Vassel, J.L., Dynamic mathematical model of high rate algal ponds (HRAP), *Water Sci. Technol.*, 2003, vol. 48, p. 197.
- Wastewater Engineering: Treatment and Reuse*, New York: McGraw-Hill, 2003.
- Binaghi, L., Del Borghi, A., Lodi, A., Converti, A., and Del Borghi, M., Batch and fed-batch uptake of carbon dioxide by *Spirulina platensis*, *Process Biochem.*, 2003, vol. 38, p. 1341.
- Powell, E.E., Mapiour, M.L., Evitts, R.W., and Hill, G.A., Growth kinetics of *Chlorella vulgaris* and its use as a cathodic half cell, *Bioresour. Technol.*, 2009, vol. 100, p. 269.
- Carvalho, A.P. and Malcata, F.X., Transfer of carbon dioxide within cultures of microalgae: plain bubbling versus hollow-fiber modules, *Biotechnol. Prog.*, 2001, vol. 17, p. 265.
- Dong, Q.L. and Zhao, X.M., In situ carbon dioxide fixation in the process of natural astaxanthin production by a mixed culture of *Haematococcus pluvialis* and *Phaffia rhodozyma*, *Catal. Today*, 2004, vol. 98, p. 537.
- Fogler, H.S., *Elements of Chemical Reaction Engineering*, Upper Saddle River, N.J.: Pearson Education, 2006.
- Lion, L.W., *Reactor Characteristics, CEE 453: Laboratory Research in Environmental Engineering*, Ithaca, N.Y.: Cornell Univ., 2006.
- Garrido, J.M., van Benthum, W.A.J., van Loosdrecht, M.C.M., and Heijnen, J.J., Influence of dissolved oxygen concentration on nitrite accumulation in a biofilm airlift suspension reactor, *Biotechnol. Bioeng.*, 1997, vol. 53, p. 168.
- Langenhoff, A.A.M. and Stuckey, D.C., Treatment of dilute wastewater using an anaerobic baffled reactor: effect of low temperature, *Water Res.*, 2000, vol. 34, p. 3867.
- Ouarghi, E.I., Boumansour, B.E., Dufayt, O., Hamouri, E.I., and Vassel, J.L., Hydrodynamics and oxygen balance in a high-rate algal pond, *Water Sci. Technol.*, 2000, vol. 42, p. 349.
- Levenspiel, O., *The Chemical Reactor Omnibook*, Corvallis, Ore.: Oregon State University Book Stores, 1989.
- Kadlec, R.H. and Knight, R.L., *Treatment Wetlands*, Boca Raton, Fla.: CRC, 1996.
- Li, L., Effects of initial microbial density on disinfection efficiency in a continuous flow system and validation of disinfection batch kinetics in a continuous flow system, *PhD Dissertation*, Philadelphia: Drexel University, 2004.
- Burrows, L.J., West, J.R., Forster, C.F., and Martin, A., Mixing studies in an Orbital activated sludge system, *Water SA*, 2001, vol. 27, p. 79.
- Wang, Y., Sanly, Brannock, M., and Leslie, G., Diagnosis of membrane bioreactor performance through residence time distribution measurements—a preliminary study, *Desalination*, 2009, vol. 236, p. 120.
- Padoley, K.V., Rajvaidya, A.S., Subbarao, T.V., and Pandey, R.A., Biodegradation of pyridine in a completely mixed activated sludge process, *Bioresour. Technol.*, 2006, vol. 97, p. 1225.
- Saravanathamizhana, R., Paranthamana, R., Balasubramaniana, N., and Ahmed, B.C., Residence time distribution in continuous stirred tank electrochemical reactor, *Chem. Eng. J.*, 2008, vol. 142, p. 209.
- Escudié, R., Conte, T., Steyer, J.P., and Delgenés, J.P., Hydrodynamic and biokinetic models of an anaerobic fixed-bed reactor, *Process Biochem.*, 2005, vol. 40, p. 2311.
- Lima, A. and Hodouin, D., Residence time distribution of an industrial mechanically agitated cyanidation tank, *Miner. Eng.*, 2005, vol. 18, p. 613.
- Tizghadam, M., Dagot, C., and Baudu, M., Wastewater treatment in a hybrid activated sludge baffled reactor, *J. Hazard. Mater.*, 2008, vol. 154, p. 550.
- Yu, X., Putz, G., Mazurek, K.A., and Albers, C., Effect of columns on the flow behavior and residence time distribution in a water treatment plant clearwell, *Proc. CSCE 2008 Ann. Conf.*, Quebec City, Canada, 2008.
- Krishna, G.G., Kumar, P., and Kumar, P., Treatment of low-strength soluble wastewater using an anaerobic baffled reactor (ABR), *J. Environ. Manage.*, 2009, vol. 90, p. 166.
- Persson, J., Somes, N.L.G., and Wong, T.H.F., Hydraulics efficiency of constructed wetlands and ponds, *Water Sci. Technol.*, 1999, vol. 40, p. 291.
- Singh, S., Haberl, R., Moog, O., Shrestha, R.R., Shrestha, P., and Shrestha, R., Performance of an anaerobic baffled reactor and hybrid constructed wetland treating high-strength wastewater in Nepal—a model for DEWATS, *Ecol. Eng.*, 2009, vol. 35, p. 654.
- Morrill, A.B., Sedimentation basin research and design, *J. Am. Water Works Assoc.*, 1932, vol. 24, p. 1442.
- US EPA Design Manual, Municipal Wastewater Disinfection: EPA/625/1-86/021*, Cincinnati: U.S. Environmental Protection Agency, 1986.
- Maksymetz, B., Development of a real-time disinfection (CT) program at a large conventional water treatment plant, *Proc. WCWWA Conf.*, Calgary, 1998.
- Kim, Y.I. and Bae, B.U., Design and evaluation of hydraulic baffled-channel PAC contactor for taste and odor removal from drinking water supplies, *Water Res.*, 2007, vol. 41, p. 2256.
- Koukou, M.K., Papayannakos, N., and Markatos, N.C., Dispersion effects on membrane reactor performance, *AIChE J.*, 1996, vol. 42, p. 2607.
- Philippou, A. and Mitchell, E., Dispersion number studies in CMP of interlayer dielectric films, *J. Electrochem. Soc.*, 2003, vol. 150, p. G854.