

Multiaxis three-dimensional weaving for composites: A review

Kadir Bilisik

Textile Research Journal 2012 82: 725 originally published online 1 February 2012

DOI: 10.1177/0040517511435013

The online version of this article can be found at:

<http://trj.sagepub.com/content/82/7/725>

Published by:



<http://www.sagepublications.com>

Additional services and information for *Textile Research Journal* can be found at:

Email Alerts: <http://trj.sagepub.com/cgi/alerts>

Subscriptions: <http://trj.sagepub.com/subscriptions>

Reprints: <http://www.sagepub.com/journalsReprints.nav>

Permissions: <http://www.sagepub.com/journalsPermissions.nav>

Citations: <http://trj.sagepub.com/content/82/7/725.refs.html>

>> [Version of Record](#) - Mar 7, 2012

[OnlineFirst Version of Record](#) - Feb 1, 2012

[What is This?](#)

Multiaxis three-dimensional weaving for composites: A review

Kadir Bilisik

Textile Research Journal
82(7) 725–743
© The Author(s) 2012
Reprints and permissions:
sagepub.co.uk/journalsPermissions.nav
DOI: 10.1177/0040517511435013
trj.sagepub.com



Abstract

The aim of this study is to review three-dimensional (3D) fabrics and a critical review is especially provided on the development of multiaxis 3D woven preform structures and techniques. 3D preforms are classified based on various parameters depending on the fiber sets, fiber orientation and interlacements, and micro–meso unit cells and macro geometry. Biaxial and triaxial two-dimensional (2D) fabrics have been widely used as structural composite parts in various technical areas. However, they suffer delamination between their layers due to the lack of fibers. 3D woven fabrics have multiple layers and no delamination due to the presence of Z-fibers. However, the 3D woven fabrics have low in-plane properties. Multiaxis 3D knitted fabrics have no delamination and their in-plane properties are enhanced due to the \pm bias yarn layers. However, they have limitations regarding multiple layering and layer sequences. Multiaxis 3D woven fabrics have multiple layers and no delamination due to Z-fibers and in-plane properties enhanced due to the \pm bias yarn layers. Also, the layer sequence can be arranged based on end-use requirements. However, the multiaxis 3D weaving technique is at an early stage of development and needs to be fully automated. This will be a future technological challenge in the area of multiaxis 3D weaving.

Keywords

Multiaxis 3D weaving, bias yarns, z-yarns, multiaxis 3D fully interlaced preform, orthogonal 3D woven preform, process-property relations

Introduction

Textile structural composites are widely used in various industrial sectors, such as civil and defense as they possess some improved specific properties compared to basic materials such as metal and ceramics.^{1–6} Research conducted on textile structural composites has shown that they can be considered as alternative materials since they are delamination-free and damage tolerant.^{3,7} Two-dimensional (2D) biaxial, triaxial and three-dimensional (3D) fabric structures are used as structural elements in medical, space and rocket propulsions and transportation industries.⁸ Examples of these elements are plate, stiffened panels, beams and spars, shell or skin structures, hip and medical devices and prostheses.^{9–11} Recently, it has been found that using nano-based high modulus fibers in 3D fabrics results in a 10-fold increase of their mechanical properties.¹²

From a textile processing viewpoint they are readily available, cheap and not labor intensive.¹ Textile preforms are made by weaving, braiding, knitting and

stitching, and also by using non-woven techniques, and can be chosen, generally, based on the end-use requirements. A simple 3D preform consists of 2D fabrics and is stitched depending on the stack sequence. Generally, 3D preforms are fabricated by using a modified weaving loom or in some cases by using specially designed automated looms and manufactured to a near-net shape to reduce scrap.^{13,14} However, it has been observed that their low in-plane properties are partly due to through-the-thickness fiber reinforcement.^{1,2,15} A multiaxis knitted preform enhances in-plane properties.¹⁶ However, it was reported that a multiaxis knitted preform suffers from limitations in its

Department of Textile Engineering, Erciyes University, Talas-Kayseri, Turkey.

Corresponding author:

Kadir Bilisik, Department of Textile Engineering, Faculty of Engineering, Erciyes University, 38039 Talas-Kayseri, Turkey
Email: kadirbilisik@gmail.com

fiber architecture and through-thickness reinforcement due to thermoplastic stitching thread and 3D shaping during molding.³ A multiaxis 3D woven preform is a relatively new concept and it is produced by a specially developed multiaxis 3D weaving technique and its in-plane properties are improved by orienting the fiber in the preform surfaces.^{17,18}

The aim of this study is to review 3D fabrics, their production methods and some of their properties. A critical review is provided on the development of multi-axis 3D woven preform structures and techniques.

Classifications of 3D fabrics

3D preforms are classified based on various parameters. These parameters depend on the fiber type and formation, fiber orientation and interlacements, and micro-meso unit cells and macro geometry. One general classification scheme was proposed by Ko and Chou.³ Another was proposed depending upon yarn interlacement and type of processing.¹⁹ In this scheme, a 3D woven preform is divided into orthogonal and multi-axis fabrics and their production process is categorized as traditional or new weaving, and those produced on specially designed looms. Chen²⁰ categorized 3D woven preforms based on macro geometry where 3D woven fabrics are considered as being of solid, hollow, shell and nodal forms. Bilisik²¹ proposed a more specific classification scheme of 3D woven preforms based on the type of interlacements, yarn orientation and number of yarn sets. In this classification scheme shown in Table 1, 3D weaving is divided into four categories of preforms: fully interlaced 3D woven, 3D orthogonal woven, multiaxis fully interlaced 3D woven and multiaxis 3D woven, which is non-interlaced inside except on the outside surface. They are further subdivided based on reinforcement directions ranging from two to five with Cartesian or polar forms. This classification scheme can be useful for further research on the development of multiaxis 3D fabric and weaving.

3D fabric structure and weaving method

2D fabric

Biaxial woven fabric. 2D woven fabric is the most widely used material in the composite industry, with its usage being at about 70%. It has two yarn sets, warp (0°) and filling (90°), which are interlaced with each other to form the fabric surface. Basically it consists of plain, twill and satin weaves which are produced by traditional weaving techniques. 2D woven fabric can be layered based on the required thickness and consolidated for rigid composites. However, 2D woven fabric suffers

from poor impact resistance because of crimp, low delamination strength due to the lack of binder fibers (Z-fibers) in the thickness direction and low in-plane shear properties because of no off-axis fiber orientation other than the material's principal direction.⁴ Although a 2D layered stitched preform eliminates delamination weakness, it can reduce the in-plane properties.^{1,2}

Biaxial non-crimp fabric. A biaxial non-crimped fabric was developed to replace the unidirectional, cross-ply lamina structure.²² The fabric has basically two sets of fibers: filling and warp, and locking fibers. The warp is positioned in the 0° direction and the filling on the warp layer in the cross-direction (90°) and two sets of fibers are locked by two sets of stitching yarns. One is directed to 0° and the other is directed to 90° . A traditional weaving loom was modified to produce such fabrics. Additional warp beam and filling insertions were mounted on the loom. It was also demonstrated that 3D shell shapes with high modulus fibers can be knitted by a weft knitting machine with a fabric control sinker device as shown in Figure 1.

Triaxial fabrics. Triaxial weave has basically three sets of yarns: \pm bias (\pm warp) and filling.²³ They interlace with each other at about a 60° angle to form the fabric as shown in Figure 2. The interlacement is similar to that of traditional fabric, which means one set of yarns is above and below the other and this repeats throughout the fabric width and length. This fabric generally has a large open area between the interlacements. Dense fabrics can also be produced. However, it may not be woven in a very dense structure compared to traditional fabrics. This weaving process usually has an open reed. Triaxial fabrics have been developed basically in two variants, one of loose-weave and the other of tight weave. The structure was evaluated and it was concluded that the open-weave triaxial fabric has a certain degree of stability and shear stiffness in the $\pm 45^\circ$ direction compared to the biaxial fabrics; it also has more isotropy.²⁴

3D orthogonal fabric

3D orthogonal woven preforms have three yarn sets: warp, filling and z-yarns.²⁵ These sets of yarns are all interlaced to form the structure wherein warp yarns are longitudinal and the others are orthogonal. Filling yarns are inserted between the warp layers and double picks are formed. The z-yarns are used for binding the other yarn sets to provide structural integrity. The unit cell of the structure is given in Figure 3.

A state-of-the-art weaving loom was modified to produce 3D orthogonal woven fabric.²⁶ For instance, one of the looms for carpet, which has three rigid rapier

Table 1. The classification of 3D weaving based on interlacement and fiber axis.

Number of yarn sets	3D weaving							
	Fully interlaced 3D woven		Orthogonal 3D woven		Multiaxis fully interlaced woven		Multiaxis 3D woven	
	Cartesian	Polar	Cartesian	Polar	Cartesian	Polar	Cartesian	Polar
2 or 3	Angle interlock	Tubular						
	<ul style="list-style-type: none"> • layer-to-layer Core structure							
3	<ul style="list-style-type: none"> • rectangular • triangular • double layer • angularly oriented • diamond 							
	Plain	Plain	Open-lattice	Tubular				
	<ul style="list-style-type: none"> • Plain weft or Z-laid-in 	<ul style="list-style-type: none"> • plain radial or circumferential laid-in 	Solid					
	Twill <ul style="list-style-type: none"> • twill weft or Z-laid-in Satin <ul style="list-style-type: none"> • satin weft or Z-laid-in 	Twill <ul style="list-style-type: none"> • twill radial or circumferential laid-in Satin <ul style="list-style-type: none"> • satin radial or circumferential laid-in 						
4								
5								

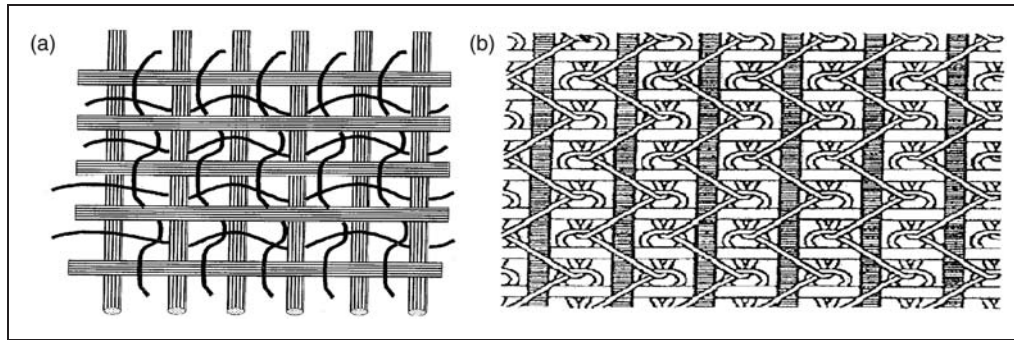

Figure 1. Non-interlace woven fabric (a)²² and warp inserted knitted fabric (b).³

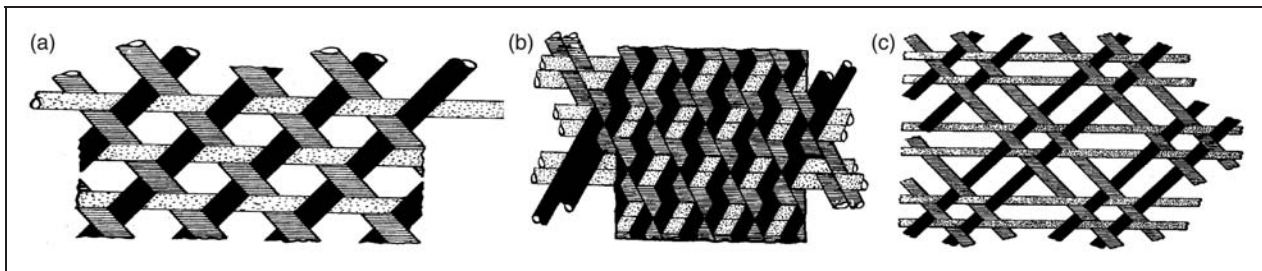

Figure 2. Triaxial woven fabrics; loose fabric (a), tight fabric (b) and one variant of triaxial woven fabric (c).²³

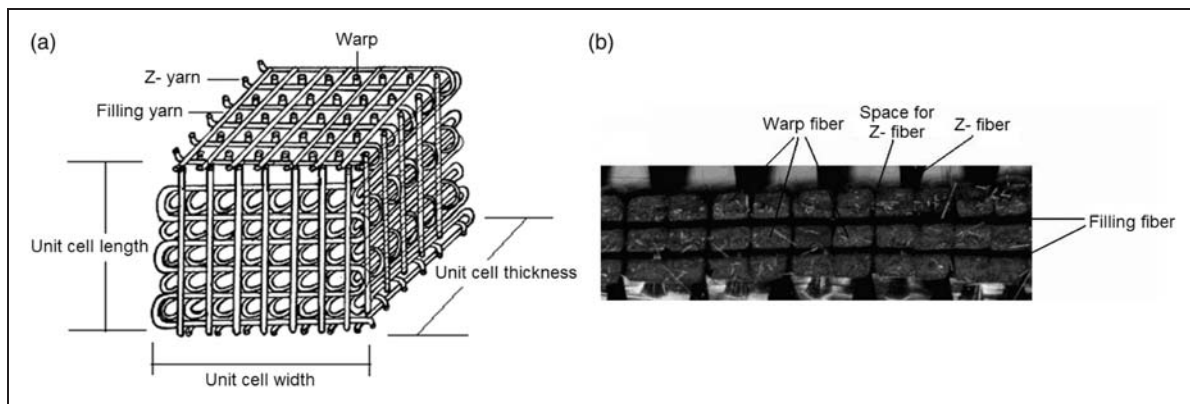

Figure 3. 3D orthogonal woven unit cell: schematic (a) and 3D woven carbon fabric preform (b).²⁵

insertions with dobby type shed control systems, was converted to produce 3D woven preforms as seen in Figure 4(a). The new weaving loom was also designed to produce various sectional 3D woven preform fabrics as seen in Figure 4(b).

On the other hand, specially designed weaving looms for 3D orthogonal woven preforms were developed to make parts for structural applications such as billet and conical frustum.^{28,29} These looms are shown in Figure 5. The first loom was developed based on the needle insertion principle as shown in Figure 5(a),

whereas the second loom was developed on the rapier-tube insertion principle as seen in Figure 5(b).

3D angle interlock fabrics were fabricated by a 3D weaving loom.³⁰ They are considered as layer-to-layer and through-the-thickness fabrics as shown in Figure 6. Layer-to-layer fabric has four sets of yarns: filling, \pm bias and stuffer yarns (warp). \pm Bias yarns are oriented in the thickness direction and interlaced with several filling yarns. Bias yarns make zig-zag movements in the thickness direction of the structure and change the course of the structure in the machine

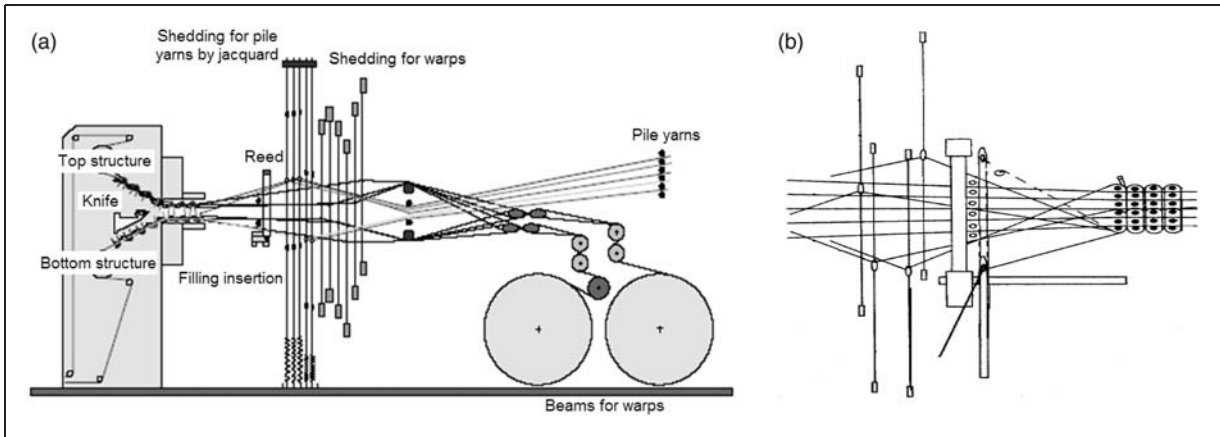

Figure 4. Traditional weaving loom (a) and new weaving loom (b) producing 3D orthogonal woven fabrics.^{26,27}

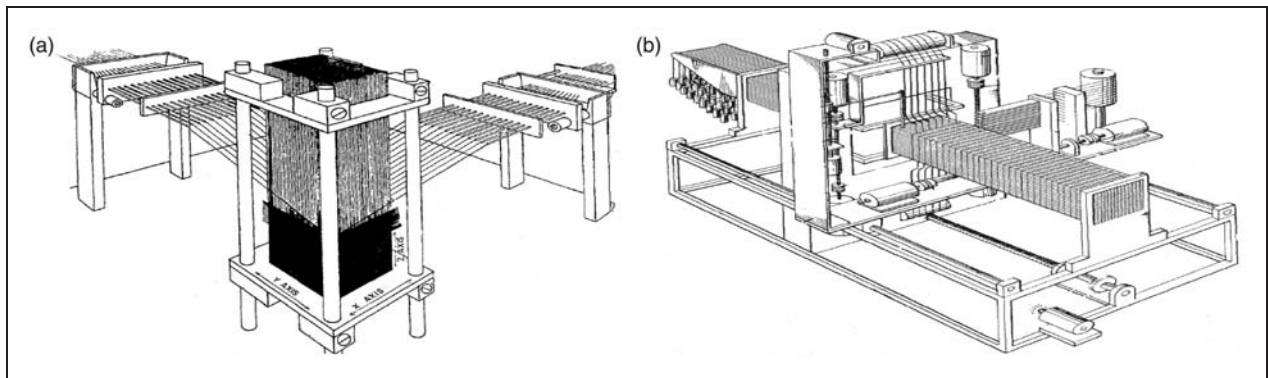

Figure 5. 3D weaving looms for thick part manufacturing based on needle (a) and rapier (b) principles.^{28,29}

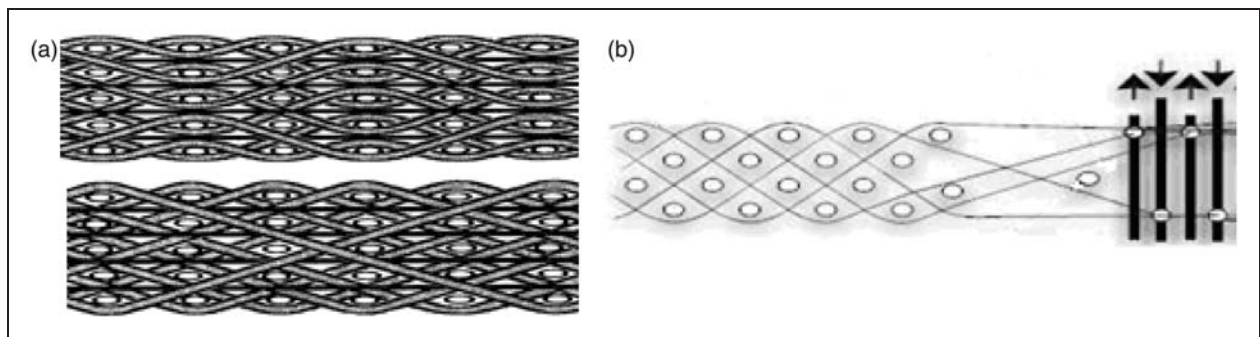

Figure 6. 3D angle interlock fabrics (a) and schematic view of 3D weaving loom (b).³¹

direction. Likewise, through-the-thickness fabric has four sets of fibers: \pm bias, stuffer yarn (warp) and fillings. \pm Bias yarns are oriented in the thickness direction of the structure. Each bias yarn is oriented until it comes to the top or bottom face of the structure. Then, it is moved towards the top or bottom faces until it comes to the edge. Bias yarns are locked by several filling yarns according to the number of layers.

Another type of 3D orthogonal woven fabric, in which the pultruded rod is layered, was introduced. \pm Bias yarns are inserted between the diagonal rows and columns to open the warp layers at a cross-section of the woven preform structure.³² The process includes a \pm bias insertion needle assembly, warp layer assembly and hook holder assembly as shown in Figure 7. The warp yarns are arranged in matrix array according to the preform cross-section. A pair of multiple latch

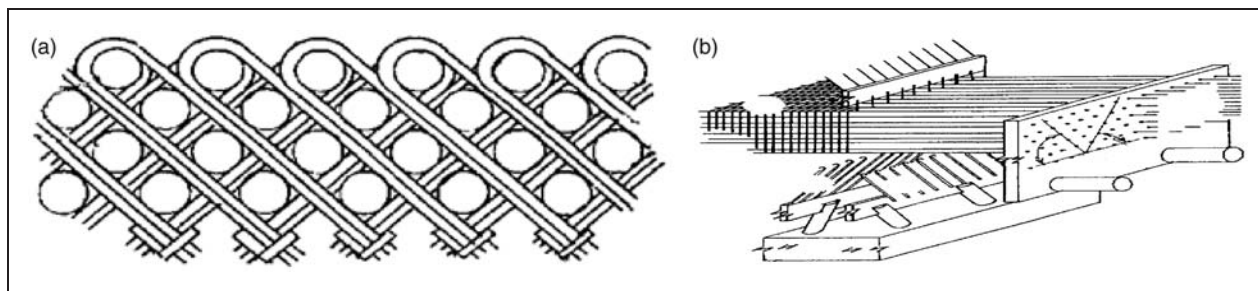

Figure 7. 3D orthogonal fabric at an angle in cross-section (a) and production loom (b).³²

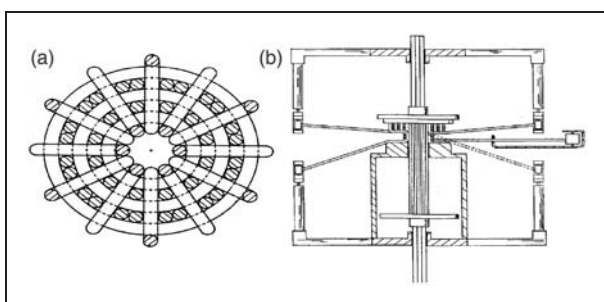

Figure 8. 3D circular woven preform (a) and weaving loom schematic (b).³³

needle insertion systems inserts \pm bias yarns at the cross-sections of the structure at an angle of about 60° . Loop holder fingers secure the bias loop for the next bias insertion and pass to the previous loop.

3D circular weaving (or 3D polar weaving) was also developed.³³ A preform has mainly three sets of yarns, axial, radial and circumferential, to create a cylindrical shape and addition of the central yarns for rod formation as shown in Figure 8. The device has a rotating table for holding the axial yarns, a pair of carriers which extend vertically up and down to insert the radial yarn and each carrier includes several radial yarn bobbins and finally a guide frame for regulating the weaving position. A circumferential yarn bobbin is placed on the radial position of the axial yarns. After the circumferential yarn is wound over the radial yarn which is vertically positioned, the radial yarn is placed radially to the outer ring of the preform. The exchanging of bobbins results in a large shedding motion which may cause fiber damage.³³

3D orthogonal woven fabrics with various sectional shapes, such as T, I and box beams, were fabricated by a modified 2D weaving loom.³⁴ This fabric has \pm bias, warp and filling yarns. During weaving, the \pm bias fibers are placed in the web of the T shape. The flange section has warp and filling and is connected to part of the \pm bias fibers. The process is realized on a traditional

two rapier insertion loom. \pm Bias fibers are placed in the web by a Jacquard head. The \pm bias yarns were connected during the weaving of the flange section.³⁴ A 2D woven plain fabric based laminated connector was developed. It was joined adhesively to the spar and sandwiched panel in aircraft wings.³⁵ An integrated 2D shaped woven connector fabric was developed to join the sandwiched structures together for aircraft applications.³⁶ A 2D integrated woven connector has warp and filling yarns. Basically, two yarn sets are interlaced with each other. Z-fibers can be used based on the connector thickness. The connector can be woven as TT, Y, H shapes according to the joining types as shown in Figure 9. Ribs or spars in the form of sandwiched structures are joined to the connector by gluing.

Multiaxis 3D fabric

Single layer multiaxis fabric. A century ago, a multiaxis fabric, which consisted of \pm bias, warp (axial) and filling, was developed for garment and upholstery applications.³⁷ The yarn used in weaving was slit cane. The weaving loom's principal operation is the same as that of the triaxial weaving loom. The loom consists of a rotatable bias creel, a \pm bias indexing and rotating unit, axial warp feeding, rigid rapier type filling insertion and take-up units.³⁷

Tetra-axial woven fabric was introduced for structural tension member applications. The fabric has four yarn sets: \pm bias, filling and warp.³⁸ They are all interlaced together similar to traditional woven fabric. Therefore, the fabric properties are enhanced in the longitudinal direction. The process has a rotatable bias bobbin unit, a pair of pitched bias cylinders, a bias shift mechanism, shedding unit, filling insertion and warp (0°) insertion units. After the bias bobbins rotate to incline the yarns, helical slotted bias cylinders rotate to shift the bias one step similar to the indexing mechanism. Then, the bias transfer mechanism changes the position of the end of the bias yarns. Shedding bars push the bias yarns to make an opening for the filling insertion. The filling is inserted by rapier and take-up

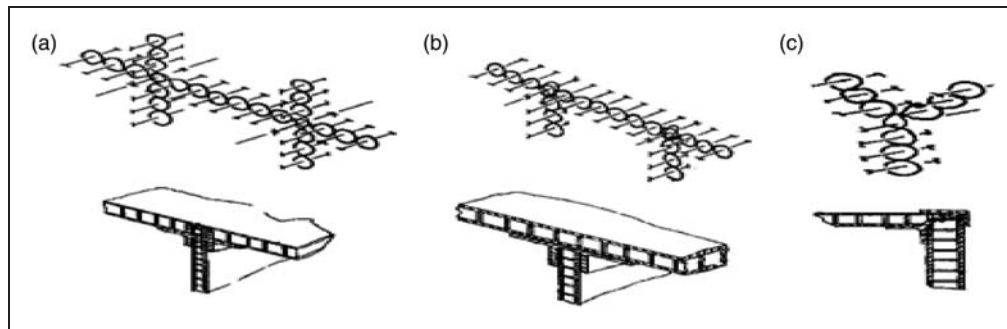

Figure 9. 2D shaped woven connectors as H shape (a), TT shape (b) and Y shape (c).³⁶

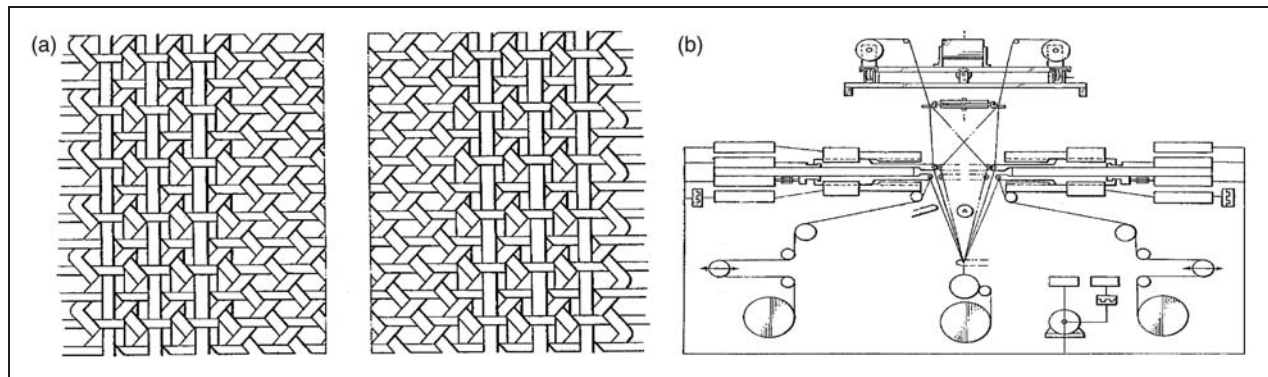

Figure 10. Quart-axial woven fabric (a) and weaving loom (b).⁴⁰

movements and the fabric continues to the next weaving cycle.³⁸ Another tetra-axial fabric has four fiber sets, \pm bias, warp and filling. In this fabric, the warp and filling have no interlacement points with each other. The filling lies under the warp and \pm bias yarns, and locks all the yarns together to provide fabric integrity.³⁹ In this way, the fabric has isotropic properties in the principal and bias directions. The process has a rotatable bias feeding system, \pm bias orientation unit, shedding bars unit, warp feeding, filling insertion and take-up. After the bias feeding unit rotates one bobbin distance, the \pm bias system rotates one yarn distance. Shedding bars push the \pm bias fiber sets towards each other to make an open space for filling insertion. The filling is inserted by a rapier and take-up delivers the fabric.³⁹

Fabric known as quart-axial fabric has four sets of fibers, \pm bias, warp and filling yarns, as shown in Figure 10. All fiber sets are interlaced with each other to form the fabric structure. However, warp yarns are introduced into the fabric at selected places depending upon the end-use.⁴⁰ The process includes rotatable \pm bias yarn beams or bobbins, close eye hook needle assembly, a warp yarn feeding unit, a filling insertion unit and an open reed for beat-up and take-up. After the \pm bias yarns rotate one bobbin distance, heddles are

shifted to one heddle distance. The warp is then fed to the weaving zone and heddles move to each other selectively to make a shed. Filling insertion takes place and an open reed beats the filling to the fabric formation zone.⁴⁰

A four-layer multiaxis 3D woven fabric was developed.⁴¹ This fabric has four yarn sets: \pm bias, warp and filling. \pm Bias yarns are placed between the warp (0°) and filling (90°) yarn sets so that they are locked by warp and filling whereby the warp and filling yarns are orthogonally positioned as shown in Figure 11. The bias yarns are positioned by the use of special split-reeds together and a Jacquard shedding mechanism with special heddles. A creel supplies the bias warp yarns in a sheet to the special heddles connected to the Jacquard head. The bias yarns then pass through the split-reed system which includes an open upper reed and an open lower reed together with guides positioned in the reed dents. The lower reed is fixed while the upper reed can be moved in the weft direction.⁴¹ The Jacquard head is used for the position selected bias yarns in the dents of the upper reed so that they can be shifted transversely in the normal warp direction. The correct positioning of the bias yarns requires a series of such lifts and transverse displacements and

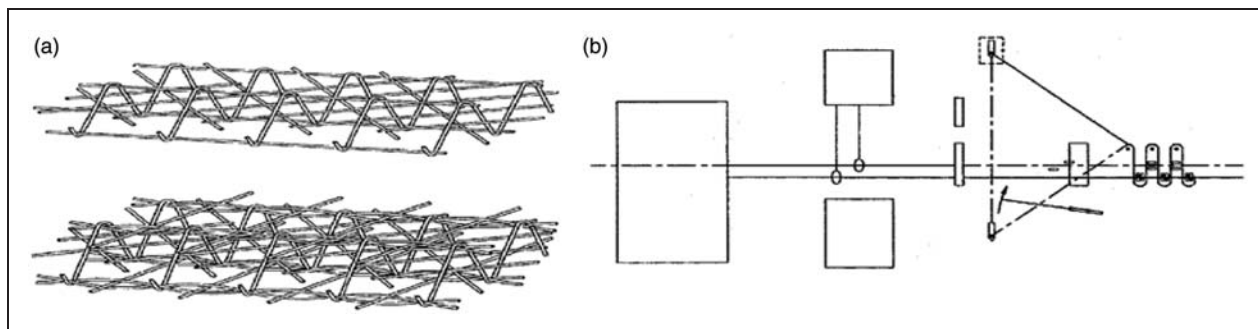

Figure 11. Four-layer multiaxis woven fabric (a) and Jacquard weaving loom (b).⁴¹

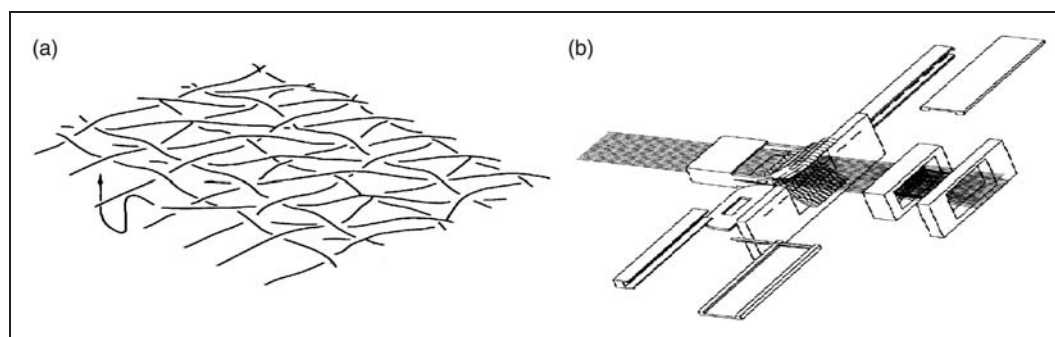

Figure 12. Four-layer multiaxis woven fabric (a) and narrow weaving loom (b).⁴²

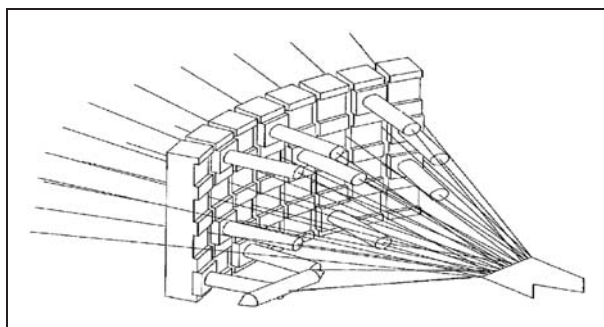

Figure 13. Schematic view of multiaxis weaving loom.⁴³

no entanglement of the warp. A shed is formed by the warp binding yarn via a needle bar system and the weft is inserted at the weft insertion station with beat-up performed by another open reed.⁴¹

Another multiaxis four-layer fabric was developed based on the multilayer narrow weaving principle.⁴² The fabric has \pm bias, warp and filling yarn sets as shown in Figure 12. It can be produced in various cross-sections such as \perp , Π , \square . Two sets of bias yarns are used during weaving and when the + bias yarns reach the selvedge of the fabric they then transverse to the opposite side of the fabric and become –

bias. All yarns are interlaced based on traditional plain weave.⁴²

A narrow weaving loom was modified to produce the four-layer multiaxis fabric. The basic modified part is in the bias insertion assembly. The bias yarn set is inserted by an individual hook. The basic limitation is the continuous manufacturing of the fabric. It is restricted by the bias yarn length. Such a structure may be utilized as a connector in the structural elements of aircraft components.⁴² A multiaxis weaving loom was developed to produce four-layer fabric which has \pm bias, warp and filling yarns as shown in Figure 13. The process has a warp creel, a shuttle for filling insertion, a braider carrier for + bias or – bias yarns, an open reed and take-up. Bias carriers are moved on a predetermined path based on the cross-sectional shape of the fabric. The filling is inserted by the shuttle to interlace it with the warp as in traditional weaving. An open reed beats the inserted filling to the fabric fell line to provide structural integrity.⁴³

Multilayer multiaxis fabric. A multiaxis 3D woven fabric, method and machine based on lappet weaving principles were introduced by Ruzand and Guenot.⁴⁴ The fabric has four yarn sets, \pm bias, warp and filling,

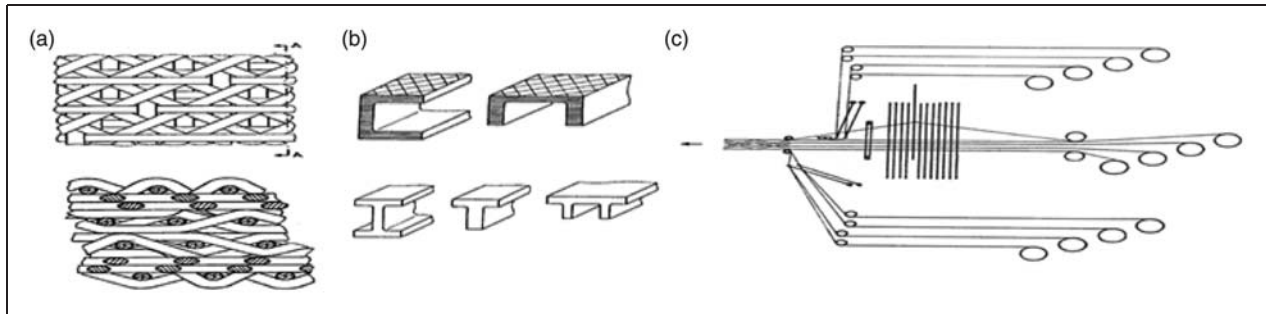

Figure 14. Multiaxis 3D woven fabric (a), structural parts (b) and loom based on lappet weaving (c).⁴⁴

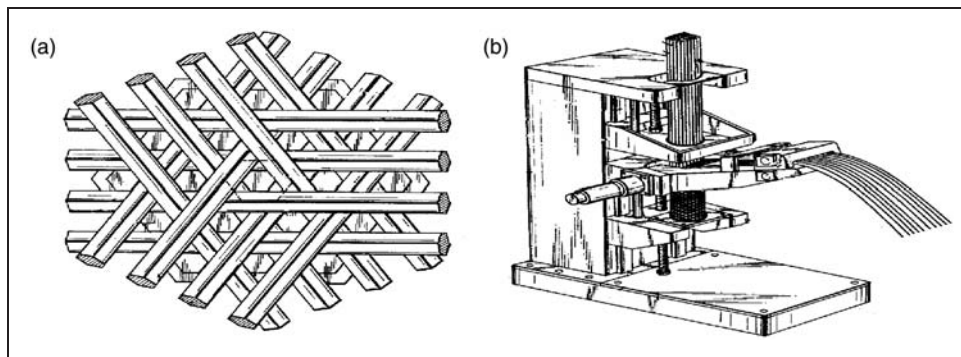

Figure 15. Multiaxis pultruded rod fabric (a) and device to produce the fabric (b).⁴⁵

as shown in Figure 14. The bias yarns run across the full width of the fabric in two opposing layers on the top and bottom surfaces of the fabric, or if required on only one surface. They are held in position using selected weft yarns interlaced with warp binding yarns on the two surfaces of the structure. The intermediate layers between the two surfaces are composed of other warp and weft yarns which may be interlaced.⁴⁴ The basis of the technique is an extension of lappet weaving in which pairs of lappet bars are used on one or both sides of the fabric. The lappet bars are re-segmented and longer than the fabric width by one segment length. Each pair of lappet bars moves in an opposite direction with no reversal in the motion of a segment until they fully exceed the opposite fabric selvedge. When the lappet passes across the fabric width, the segment in the lappet bar is detached, its yarns are gripped between the selvedge and the guides, and it is cut near the selvedge. The detached segment is then transferred to the opposite side of the fabric where it is reattached to the lappet bar and its yarn subsequently connected to the fabric selvedge. Since a rapier is used for weft insertion, the bias yarns can be consolidated into the selvedge by an appropriate selvedge-forming device employed for weaving. The bias warp supply for each lappet bar segment is independent and does not interfere with the yarns from other segments.⁴⁴

A multiaxis structure and process have been developed to produce the fabrics. The pultruded rods are arranged in a hexagonal array as warp yarns as shown in Figure 15. Three sets of rods are inserted into the cross-section of such an array at an angle of about 60° . The properties of the structure may distribute isotropically depending upon end-use.⁴⁵

A fabric has been developed where the \pm bias yarns are inserted into the traditional 3D lattice fabric's cross-section at an angle of $\pm 45^\circ$. The fabric has warp, filling and Z-yarns which are orthogonal arrangements and plain type interlaced fiber sets are used as the (Z-yarn)-interlace and filling-interlace as shown in Figure 16. The \pm bias yarns are inserted into such a structure's cross-section at $\pm 45^\circ$. The fabric has a complex internal geometry and the production of such a structure may not be feasible.⁴⁶

Anahara and Yasui⁴⁷ developed a multiaxis 3D woven fabric. In this fabric, the normal warp, bias and weft yarns are held in place by vertical binder yarns. The weft is inserted as double picks using a rapier needle which also performs beat-up. The weft insertion requires the normal warp and bias layers to form a shed via shafts which do not use heddles but rather have horizontal guide rods to maintain the vertical separation of these layers. The binders are introduced simultaneously across the fabric width by

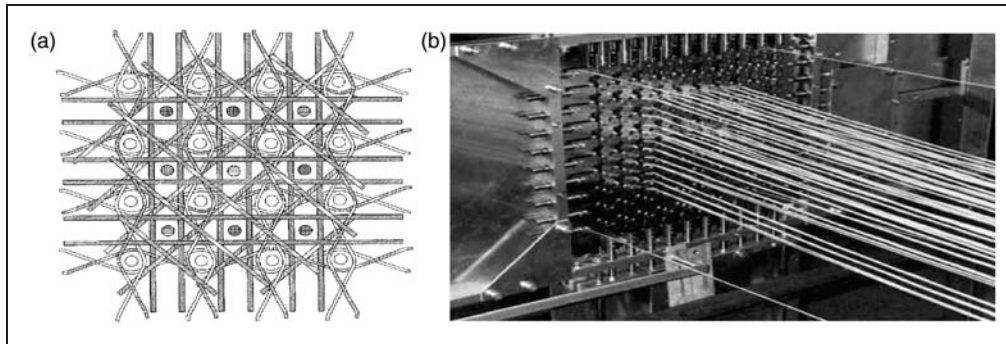

Figure 16. The fabric (a) and specially designed loom to fabricate the multiaxis 3D fabric (b).⁴⁶

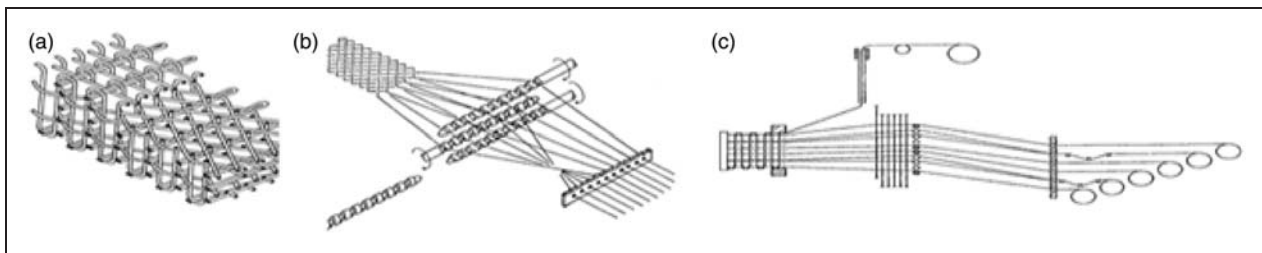

Figure 17. The multiaxis 3D woven fabric (a), indexing mechanism for \pm bias (b) and loom (c).⁴⁷

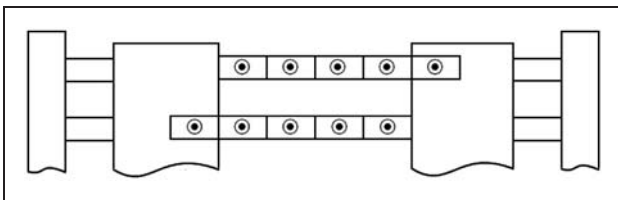

Figure 18. Guide block mechanism for \pm bias yarns.⁴⁷

a vertical guide bar assembly comprising a number of pipes with each pipe controlling one binder as shown in Figure 17.

The bias yarns are continuous throughout the fabric length and traverse the fabric width from one selvedge to the other in a cross-laid structure. Lateral positioning and cross-laying of the bias yarns are achieved by using an indexing screw-shaft system. As the bias yarns are folded downwards at the end of their traverse, there is no need to rotate the bias yarn supply. Therefore, the bias yarns can supply on warp beams or from a warp creel, but they must be appropriately tensioned due to path length differences at any instant of weaving. A bias yarn placement mechanism has been modified instead of using an indexing screw-shaft system; actuated guide blocks are used to place the bias yarns as shown in Figure 18. The folded structure of the bias yarns results in each layer having triangular sections which alternate in the direction of the bias angle in about the warp

direction due to the bias yarn interchanges between adjacent layers. The bias yarns are threaded through individual guide blocks which are controlled by a special shaft to circulate in one direction around a rectangular path. Obviously, this requires rotation of the bias yarn supply.⁴⁷

Uchida et al.⁴⁸ developed the fabric called the 'five-axis 3D woven' which has five yarn sets: \pm bias, filling, warp and Z-fiber. The fabric has four layers and sequences, + bias, -bias, warp and filling from top to bottom. All layers are locked by Z-fibers as shown in Figure 19. The process has a bias rotating unit, filling insertion, Z-yarn insertion, warp, \pm bias and Z-fiber feeding units, and take-up. A horizontally positioned bias chain, which rotates one bias yarn distance to orient the yarns, and filling is inserted into the fixed shed. Then the Z-yarn rapier inserts the Z-yarn to bind all yarns together and all Z-yarn units are moved to the fabric fell line to carry out the beat-up function. The take-up removes the fabric from the weaving zone.⁴⁸

Mohamed and Bilisik¹⁷ developed a multiaxis 3D woven fabric, method and machine in which the fabric has five yarn sets: \pm bias, warp, filling and Z-fiber. Many warp layers are positioned in the middle of the structure. The \pm bias yarns are positioned on the back and front faces of the preform and lock the other set of yarns by the Z-yarns as shown in Figure 20.

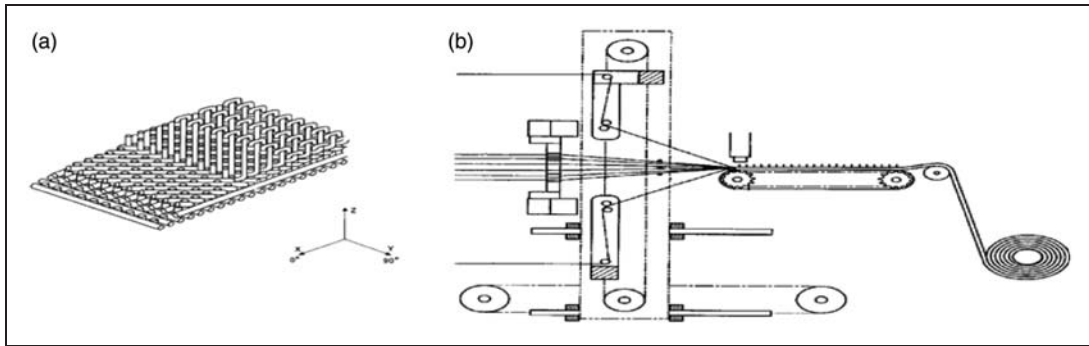

Figure 19. Five-axis fabric (a) and newly developed weaving loom (b).⁴⁸

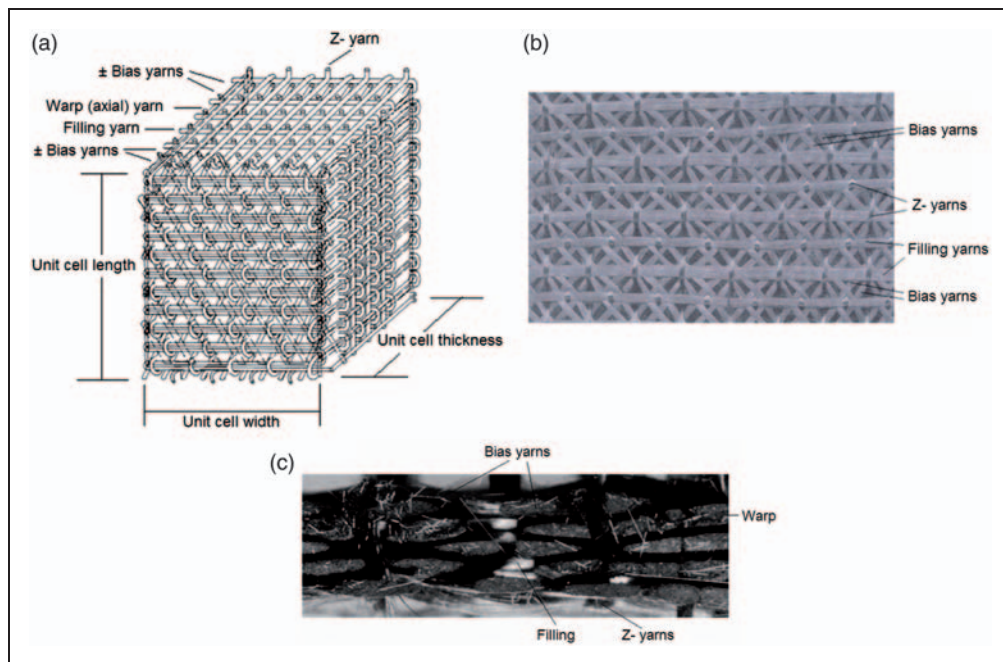

Figure 20. The unit cell of multiaxis fabric (a), top surface of multiaxis small tow size carbon fabric (b) and cross-section of the multiaxis carbon fabric (c).^{17,49}

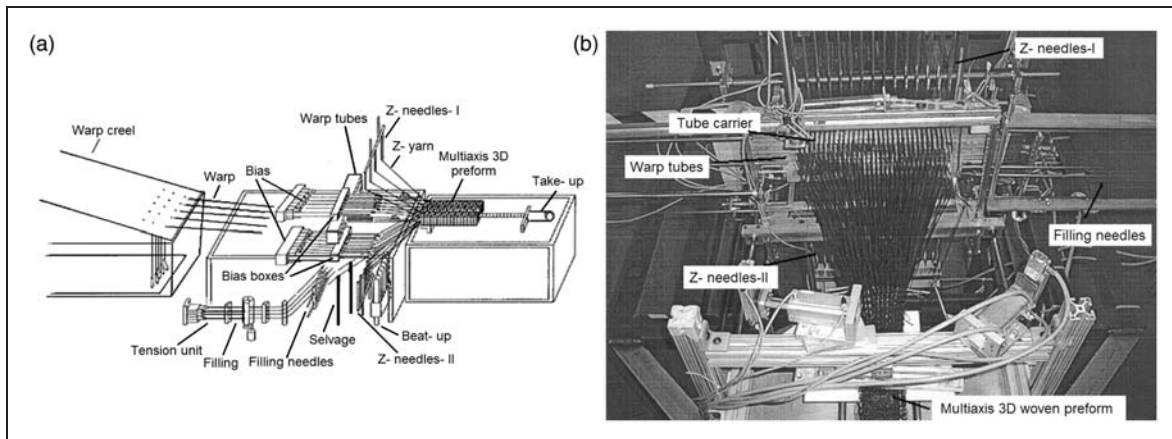

Figure 21. Schematic view of multiaxis weaving machine (a) and top side view of multiaxis weaving machine (b).^{17,50}

This structure can enhance the in-plane properties of the resulting composites.

The warp yarns are arranged in a matrix of rows and columns within the required cross-sectional shape. After the front and back pairs of the bias layers are oriented relative to each other by the pair of tube rapiers, the filling yarns are inserted by needles between the rows of warp (axial) yarns and the loops of the filling yarns are secured by the selvage yarn at the opposite side of the preform by selvage needles and cooperating latch needles. Then, they return to their initial position as shown in Figure 21. The Z-yarn needles are inserted into both the front and back surface of the preform and pass across each other between the columns of the warp yarns to lay the Z-yarns in place across the previously inserted filling yarns. The filling is again inserted by filling insertion needles and secured by the selvage needle at the opposite side of the preform. Then, the filling insertion needles return to their starting position. After this, the Z-yarns are returned to their starting position by the Z-yarn insertion needles by passing between the columns of the warp yarns once again and locking the bias yarn and filling yarns into place in the woven preform. The inserted filling, \pm bias and Z-yarns are beaten into place against the woven line as shown in Figure 22, and a take-up system moves the woven preform.

Bilisik⁵¹ developed a multiaxis 3D circular woven fabric, method and machine. The preform is basically composed of the multiple axial and radial yarns, multiple circumferential and the \pm bias layers as shown in Figure 23. The axial yarns (warp) are arranged in radial

rows and circumferential layers within the required cross-sectional shape. The \pm bias yarns are placed at the outside and inside of the ring of the cylinder surface. The filling (circumferential) yarns lie between each of the warp yarn's helical corridors. The radial yarns (Z-fiber) lock all the yarn sets to form the cylindrical 3D preform. A cylindrical preform can be made with a thin or thick wall section depending upon end-use requirements.⁵¹

The process has been designed based on the 3D braiding principle. It has a machine bed, \pm bias and filling ring carriers, radial braider, warp creel and take-up. After the bias yarns are oriented at $\pm 45^\circ$ to each other on the surface of the preform, the carriers rotate around the adjacent axial layers to wind the circumferential yarns. The radial yarns are inserted into each other by the special carrier units and they lock the circumferential yarn layers with the \pm bias and axial layers all together. A take-up system removes the structure from the weaving zone. This describes one cycle of the operation required to weave the multiaxial 3D circular woven preform. It is thought that the torsional properties of the preform are improved because of the bias yarn layers.

Multiaxis 3D knitted fabric

Wilkins⁵³ introduced a multiaxis warp knit fabric for Karl Mayer Textilmaschinenfabrik GmbH. The multiaxis warp knitting machine which produces the multiaxis warp knit fabric was developed by Naumann and Wilkins.⁵⁴ The fabric has warp (0° yarn), filling (90°

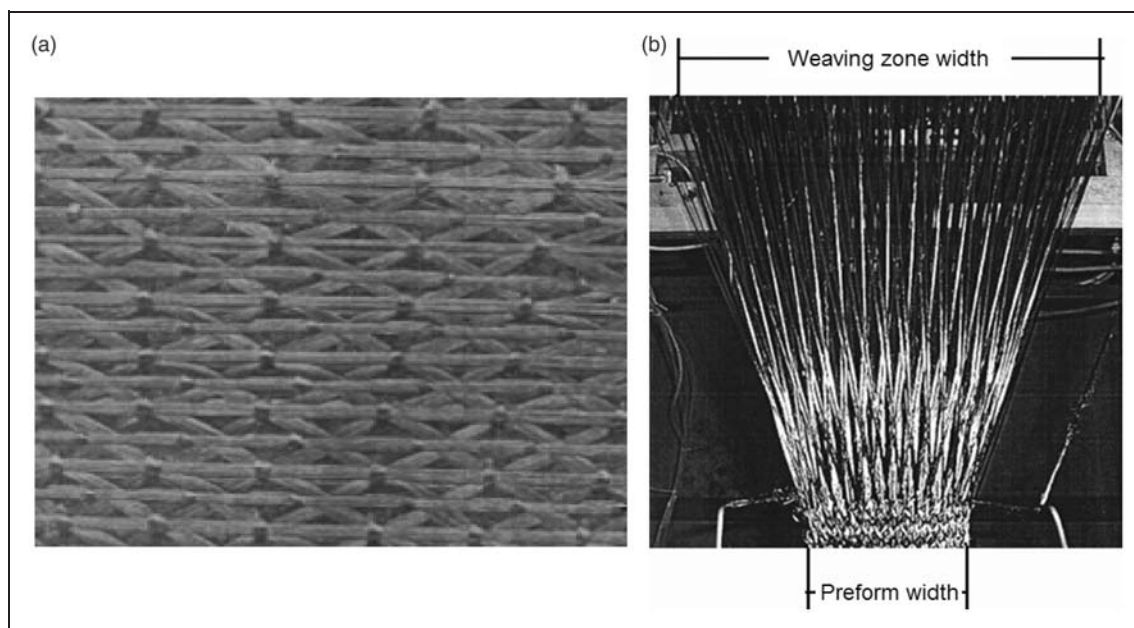

Figure 22. Top surface of multiaxis large tow size carbon fabric (a) and weaving zone of the multiaxis weaving machine (b).²⁵

yarn), \pm bias yarns and stitching yarns as shown in Figure 24. The machine includes a \pm bias beam, \pm bias shifting unit, warp beam feeding unit, filling laying-in unit and stitching unit. After the bias yarn rotates one bias yarn distance to orient the fibers, the filling lies in the predetermined movable magazine to feed the filling into the knitting zone. The warp ends are then fed to the knitting zone and the stitching needle locks all the yarn sets to form the fabric. To eliminate the bias yarn inclination in the feeding system, the machine bed rotates around the fabric. The stitching pattern, tricot or chain, can be arranged according to the end-use requirements.⁵⁴

Hutson⁵⁵ developed a fabric which is similar to the multiaxis knitted fabric. This fabric has three sets of yarns, \pm bias and filling (90° yarn), and the stitching yarns which lock all the yarn sets to provide structural integrity. The process basically includes a machine track, lay down fiber carrier, stitching unit, fiber feeding and take-up. The +bias, filling and -bias are laid according to the yarn layer sequence in the fabric. The pinned track delivers the layers to the stitching

zone. A compound needle locks all the yarn layers to form the fabric.⁵⁵ Wunner⁵⁶ developed a machine for the production of a fabric called multiaxis warp knit for Liba GmbH. It has four yarn sets, \pm bias, warp and filling (90° yarn), and stitching yarn. All layers are locked by the stitching yarn in which the tricot pattern is used as shown in Figure 25. The process includes a pinned conveyor bed, fiber carrier for each yarn set, stitching unit, yarn creels and take-up.⁵⁶

A multiaxis warp knit/braided/stitching type structure for an aircraft wing-box has been developed by NASA/BOEING. The multiaxis warp knit fabric is sequenced and cut from two to 20 layers to produce a complex aircraft wing skin structure. Then, a triaxial braided tube is collapsed to produce a stiffener spar. All of them are stitched by a multi-head stitching machine which was developed by the Advanced Composite Technology Program. The stitching density is 3 columns/cm. The complex contour shape can be stitched according to requirements as shown in Figure 26. When the carbon dry preform is ready, the resin film infusion technique is used to produce the rigid composites.

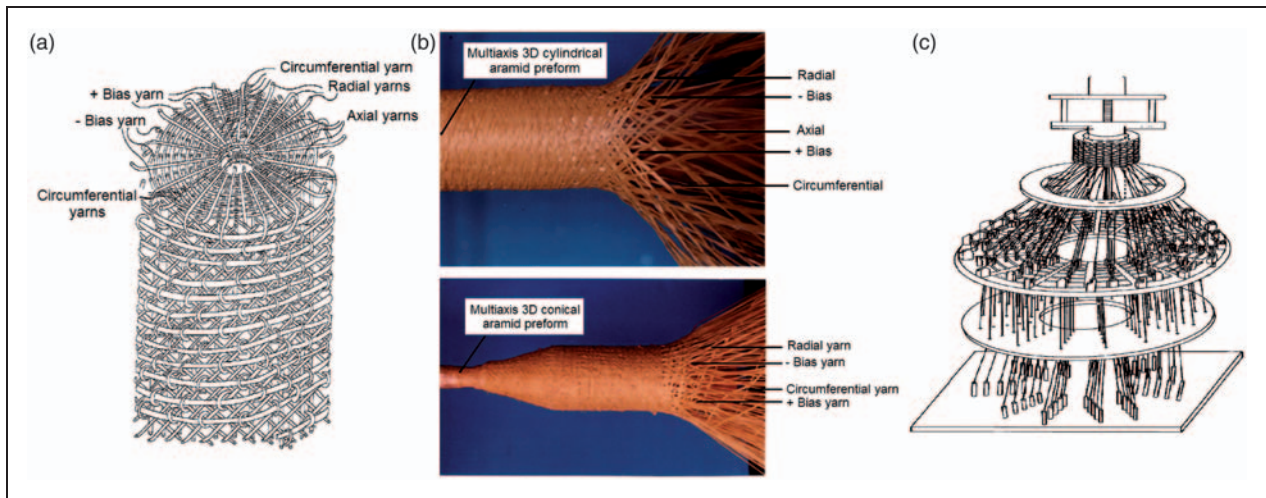

Figure 23. The unit cell of multiaxis 3D circular woven fabric (a), multiaxis 3D aramid circular woven fabric (b) and the weaving loom (c).^{51,52}

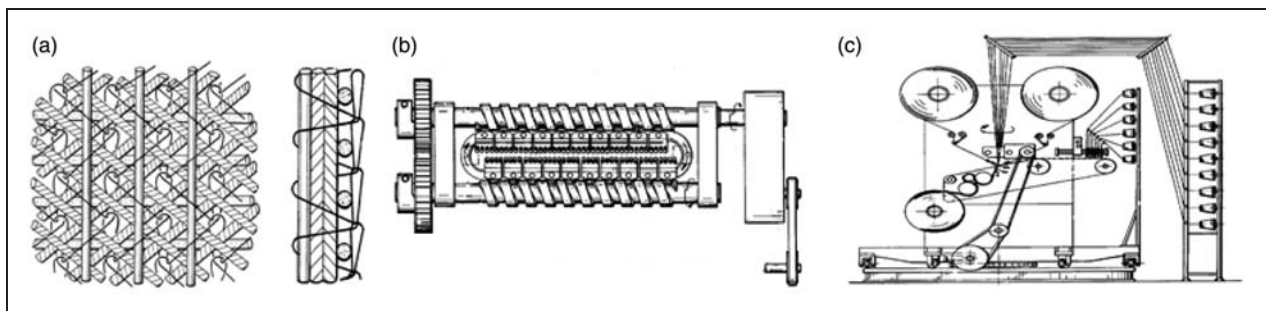

Figure 24. Top and side views of multiaxis warp knit fabric⁵³ (a), bias indexing mechanism (b) and warp knitting machine (c).⁵⁴

In this way, 25% weight reduction and 20% cost savings can be achieved in the aircraft structural parts. In addition, the structures have high damage tolerance properties.¹

Comparison of fabric and methods

Kamiya et al.² compared multiaxis 3D woven fabrics and methods based on the bias fiber placement and uniformity, the number of layers and through-the-thickness (Z-yarn) reinforcements. They concluded that the biaxial fabric/stitching, and the multiaxis knitted fabric and methods are readily available. They recommended that multiaxis 3D woven fabrics and methods should be developed further. A more general comparison is carried out and is presented in Table 2. As seen in the Table 2, the multiaxis 3D fabric

parameters are the yarn sets, interlacement, yarn directions, multiple layer and fiber volume fraction. The multiaxis 3D weaving process parameters are the bias unit, manufacturing type such as continuous or part, yarn insertion, packing and development stage. It can be seen that the triaxial fabrics and 3D woven fabrics are well developed and are commercially available. However, multiaxis 3D woven fabric is still in the early stages of development.

Multiaxis fabric properties and composites

Triaxial fabric

Scardino and Ko⁵⁷ reported that the fabric in the bias direction has better properties compared to the biaxial fabric. Comparisons have revealed a four-fold tearing

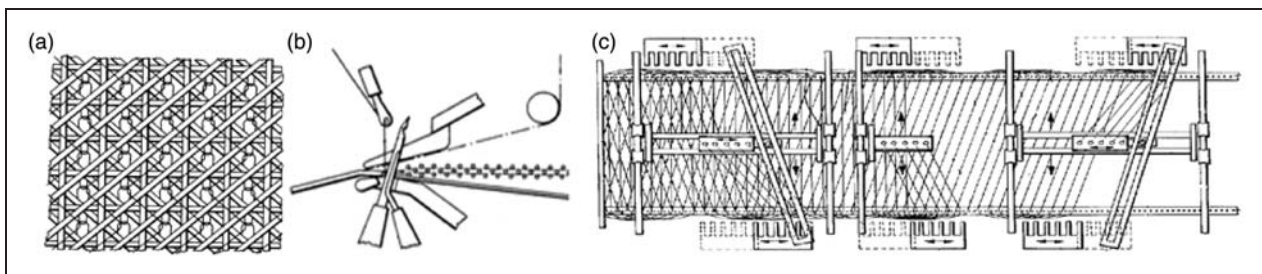

Figure 25. Warp knit structure (a), stitching unit (b) and warp knit machine (c).⁵⁶

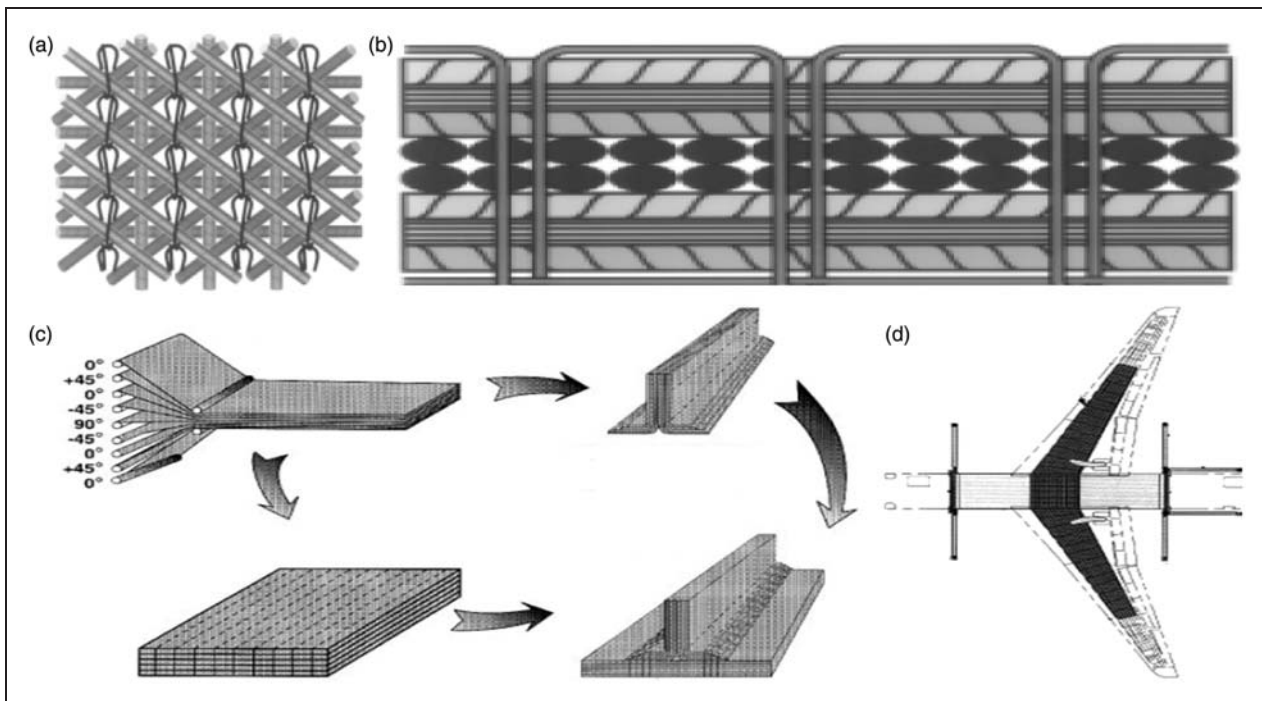

Figure 26. Warp knit structure (a), multilayer stitched warp knit structure (b), layering-stitching-shaping (c) and application in airplane wing structure (d).¹

Table 2. Comparison of the multiaxis 3D fabrics and methods

Fabric	Yarn sets	Interlacement	Yarn directions	Multiple layer	Fiber volume fraction	Development stage
Ruzand and Guenot ⁴⁴	Four	Interlace, plain	Warp/weft/ \pm bias (In-plane)	Four layers	Low or medium	Commercial stage
Anahara and Yasui ⁴⁷ Uchide ¹⁸ et al.	Five	Non-interlace	Warp/weft/ \pm bias/Z-yarn (in-plane)	More than four layers	Low	Prototype stage
Mohamed and Bilisik ¹⁷	Five	Non-interlace	Warp/weft/ \pm bias/Z-yarn (in-plane)	More than four layers	Medium or high	Prototype stage
Khokar ⁴⁶	Five	Interlace, plain	Warp/weft/ \pm bias/Z-yarn (out-of-plane)	More than four layers	Low or medium	Prototype stage
Bryn ⁴² et al. Nayfeh ⁴³ et al.	Four	Interlace, plain	Warp/weft/ \pm bias (in-plane)	Four layers	Low or medium	Prototype stage
Yasui ³³ et al.	Four	Non-interlace	Axial/circumferential + or -bias (in-plane)	Five layers	Medium	Prototype stage
Bilisik ⁵¹	Five	Non-interlace	Axial/circumferential/ \pm bias/Z-yarn (in-plane)	More than four layers	High	Early prototype stage
Wilkens ⁵³	Four	Non-interlace	Warp/weft/ \pm bias/stitched yarn (in-plane)	Four layers	Medium or high	Commercial stage
Wunner ⁵⁶	Four	Non-interlace	Warp/weft/ \pm bias/stitched yarn (in-plane)	Four layers	Medium or high	Commercial stage

strength and five-fold abrasion resistance compared with a biaxial fabric with the same setting. Strength-elongation properties are roughly the same. Schwartz⁵⁸ analyzed triaxial fabrics and compared them with the leno and biaxial fabrics. He defined the triaxial unit cell and proposed the fabric moduli at the crimp removal stage. It was concluded that the equivalency in all fabrics must be carefully defined to explore to usefulness of the triaxial fabric. Schwartz suggested that when equivalence was determined, triaxial fabric has better isotropy compared to leno and plain fabrics.⁵⁸ Isotropy can be considered to depend on the fabric bursting and tearing strengths, and the shearing and bending properties. Skelton⁵⁹ proposed a bending rigidity relation depending on the angle of orientation. Triaxial fabric is independent of the orientation angle for bending. It is isotropic. Skelton noted that the stability of the triaxial fabric was much greater than that of an orthogonal fabric with the same percentage of open area. The triaxial fabric exhibited greater isotropy in its bending behavior and greater shear resistance than a comparable biaxial fabric.

General properties of 3D fabrics

3D woven fabrics are designed for use as composite structural components for various applications where structural design depends on loading conditions. Their basic parameters are fiber and matrix properties, volume fraction, preform types and yarn orientation in the preform and preform geometry. These parameters, together with end-use requirements, determine the

preform's manufacturing techniques. Many calculation methods have also been developed with the aid of computer supported numerical methods in order to predict the stiffness and strength properties and to understand the complex failure mechanism of the textile structural composite.^{4,60,61} **TEXCAD** is a comprehensive program that calculates the elastic properties of 3D angle interlock preform structure which includes progressive damage and failure analysis.⁶² **WEAVE** is a program that calculates the 3D elastic stiffness of 3D angle interlock including that in through-the-thickness and layer-to-layer woven composites.⁶³ **BINMOD** is a program based on a stiffness averaging analytical model and the finite element method used for the calculation of the 3D elastic stiffness of 3D various unit cell base woven preform composites.⁶⁴ **CCM-TEX** is a program to calculate the stiffness matrix and strength estimates for 3D angle interlock preform structures.⁶⁵ **WISETEX** is a program based on a micromechanical model that calculates elastic stiffness after defining the unit cells of 3D orthogonal or multiaxis 3D knitted preform composite structures.⁶⁶

Multiaxis 3D and 3D orthogonal fabric process-property relations

Gu⁶⁷ reported that the take-up rate of 3D weaving affects the directional and total volume fraction of 3D woven fabrics. A high packing density can be achieved if beat-up acts twice in the fabric formation line. Friction between brittle fibers such as carbon and parts of the weaving machine must be kept low to

prevent filament breakages. Bilisik²⁵ identified the most related process-product parameters of multiaxis 3D weaving. These are the bias angle, width ratio, packing, tension and fiber waviness. The bias fiber is oriented by a discrete tube-block movement. One tube-block movement is about 15–22° based on the process parameters. If it requires any angle between 15° and 75°, the tube-block must be moved by one, two or three tube distances. Small angle changes have been identified from the loom state to the out-of-loom state at an average of 46° to 42°.

The multiaxis weaving width is not equal to that of the preform as shown in Figure 22. This difference is defined as the width ratio (preform width/weaving width). This is not currently the case in 2D or 3D orthogonal weaving. The width ratio is almost 1/3 for multiaxis weaving. This is caused by excessive filling length during insertion. It has been reported that the fiber density and pick variations are observed. Some of the warp yarns which accumulated at the edges are similar to those in the middle section of the preform. When the preform cross-section is examined, a uniform yarn distribution is not achieved for all the preform volume as shown in Figure 20. This indicated that light beat-up did not apply enough pressure to the preform, and the layered warp yarns are redistributed under the initial tension. In part, the crossing of bias yarn prevents the Z-yarn from sliding the filling yarns towards the fabric line where the filling is curved. Probably, this problem is unique to multiaxis weaving. Hence, it can be concluded that the rigid beat-up is necessary. This unique problem can be solved by a special type of open reed, if the width ratio is considered the main design parameter.⁶⁸ The dry volume fraction in the fabricated preform shows that increasing the fiber content in the warp or \pm bias and filling fiber sets results in a high total preform volume fraction and that porosity in the crossing points of fiber sets in the preform is reduced.²⁵

Fiber waviness is observed during weaving in bias and filling yarn sets. The bias yarn sets do not properly compensate for excessive length during biasing on the bias yarns. Variable tensioning may be required for each bias bobbin. The filling yarn sets are mainly related to the width ratio and level of tension applied. A sophisticated tensioning device may be required for filling yarn sets. On the other hand, the brittle characteristics of carbon fiber must be considered. The bias fiber waviness is observed during weaving in the loom state. First of all, this is because of the variable tension in the bias fiber sets. Secondly, other fiber sets affect bias waviness in the fabric formation zone. Thirdly, because of the rotatable creel used for the \pm bias fiber sets, there is excessive bias fiber on the preform surface. This causes the \pm bias waviness, and is eliminated by the compensation system connected to the rotational

bias creels. The filling waviness mainly depends on width ratio, and the related processing parameter is the selvage transfer system. The Z-fiber waviness depends on the Z-fiber path which is different during one half cycle of weaving and another half cycle. This is because Z-fiber needles, which is a part of the processing parameter.

The parameters related with the multiaxis 3D circular woven fabric process are bias orientation, radial and circumferential yarn insertion, beat-up and take-up. It was found that the bias yarns on the outer and inner surfaces of the structure form helical paths and that there is a slight angle difference between them, especially in the production of thick wall preforms.⁵² There is a certain relation between preform density (fiber volume fraction), bias yarn orientation and take-up rate. More research may be required to understand the relations between these processing parameters and preform structural parameters. In circumferential yarn insertion, excessive yarn length during insertion occurs due to the diameter ratio (preform outer diameter/outermost ring diameter) which is not 1. The amount of the diameter ratio depends on the number of the rings. When excessive circumferential yarn is not retracted, this causes waviness in the structure. However, adequate tension must be applied on the circumferential yarns to get proper packing during beat-up. There are six circumferential yarn ends in each layer, which are equivalent to filling in flat weaving, during insertion. This results in a high insertion rate. It was found that there is a relation between the number of layers and the radial yarn retraction. If the number of layers in the preform increases, yarn retraction in the radial carrier increases. Retraction must be kept within the capacity of the radial carrier. It was also observed that the tension level in the radial yarn is high compared to that of circumferential yarns because of easy packing and applying a tensioning force to the bias crossing points which resists radial yarn movements during structure formation in the weaving zone. However, a certain relation exists between radial yarn tension and beat-up force. There must be an optimum tension level and beat-up force between the yarns during the weaving for proper structural formation. It was observed that the radial yarn in the structure is at a slight angle. This depends partly on the structure wall thickness and partly on the weaving zone length during structure formation. At this point, the take-up rate is a crucially important process parameter. Also, a high beat-up force causes local yarn distortion in the structure. Two types of take-up are necessary. A part manufacturing needs a mandrel and is adapted to the take-up unit. A continuous manufacturing needs a pair of coated cylinders. For both take-up units, the most important process parameter is the take-up rate during

the delivery of the fabric from the weaving zone. The take-up rate affects the fabric volume fraction and the bias angle, and relations between preform structural parameters and processing parameters should be analyzed. This will be addressed by future analytical research in take-up rate.⁵²

Multiaxis 3D and 3D orthogonal fabric composites

Cox et al. stated that low volume fraction 3D woven preforms may perform well under impact load compared to tight volume fraction 3D woven preforms.⁷ Dickinson⁶⁹ studied 3D carbon/epoxy composites. It Dickinson realized that the amount of Z-yarn and the placement of Z-yarn in the 3D woven preform influence the in-plane properties of the 3D woven structure. When the Z-yarn volume ratio increases, the in-plane properties of the 3D woven structure decrease. On the other hand, when the Z-yarn volume fraction ratio in the 3D woven composite decreases, a local delamination type failure mode on the 3D woven composite occurs. Babcock and Rose⁷⁰ explained that under the impact load, 3D woven or 2D fabric/stitched composites confined the impact energy around the local region due to the Z-yarn.

A five-axis 3D woven fabric composite was characterized by Uchida et al.¹⁸ The tensile and compression results of multiaxis 3D and stitched 2D woven laminate were comparable. The open hole tensile and compression results of the multiaxis woven structure looked better than those of the stitched 2D woven laminated structure. A Compression After Impact (CAI) test showed that the multiaxis 3D woven composite was better than the stitched 2D woven laminated structure. Also, the damaged area in terms of absorbed energy level was small in the multiaxis 3D woven composite compared to that of the stitched 2D woven laminated composite. The multiaxis 3D knitted fabric suffers from limitation in fiber architecture, through-thickness reinforcement due to thermoplastic stitching thread and 3D shaping during molding. For these reasons, multiaxis 3D knitted fabric is layered and stitched to increase damage resistance and to reduce production cost.¹

Another experimental study was conducted on multiaxis and orthogonal 3D woven composites by Bilisik.⁶⁸ The bending strength and modulus of the multiaxis and orthogonal woven composites were 569 and 715 MPa, and 43.5 and 50.5 GPa, respectively. The bending strength and modulus of the 3D orthogonal woven composites were higher than those of multiaxis 3D woven composites by about 20% and 14%, respectively. This indicates that the \pm bias yarn orientations on both surfaces of the multiaxis woven composites cause a reduction in bending properties. Bending failure in the multiaxis 3D woven composite was analyzed. It

was observed that there was bias yarn breakage at the outside surface of the warp side and a local delamination occurs between the filling and \pm bias yarns in places where it is restricted by the Z-yarn. In the 3D orthogonal woven composite, bending failure occurs at the outside surface of the structure. Initially, matrix and yarn breakages are in the normal direction of the yarn but later on these breakages turn and propagate parallel to the yarn direction. Crack propagation is restricted by the Z-yarn.

Interlaminar shear strengths were determined to be 47.1 MPa for the multiaxis woven composite and to be 52.2 MPa for the orthogonal woven composite. The interlaminar shear strength of the 3D orthogonal woven composite was higher than that of multiaxis 3D woven composites by almost 10%. The \pm bias yarns have no considerable effect on the interlaminar shear strength of the multiaxis 3D woven composite. There are directional yarn breakages mainly in the bias and warp yarns and some local yarn–matrix splitting on the warp side of the structure. On the surface, local yarn crack occurs throughout the normal direction of the warp yarn. In the 3D orthogonal woven composite, yarn and matrix cracks are observed in the shearing load on the warp side and filling direction of the structure surface.

The in-plane shear strength and modulus of the multiaxis and orthogonal woven composites were measured as 137.7 and 110.9 MPa, and 12.1 and 4.5 GPa, respectively. The in-plane shear strength and modulus of the multiaxis 3D woven composites were higher than those of multiaxis 3D woven composites by almost 25% for in-plane shear strength and 170% for in-plane shear modulus due to the addition of the \pm bias yarns on the surface of the multiaxis 3D woven composites. There was local delamination on the warp-filling yarns and local breakages on the \pm bias yarns in the through-the-thickness direction and on the surface of the multiaxis 3D woven composites for in-plane shear failure. For the 3D orthogonal woven composite, there was local yarn breakage between the warp and filling yarns and local delamination between the warp and filling yarns in the through-the-thickness direction.

Conclusion

In this study, 3D fabrics, methods and techniques were reviewed. Biaxial 2D fabrics have been widely used as structural composite parts in various technical areas. However, composite structures of biaxial 2D fabrics suffer delamination between their layers due to the lack of fibers. Biaxial methods and techniques are well developed. Triaxial fabrics have delamination, an open structure and low fabric volume fractions. However, the in-plane properties of the triaxial fabrics

become homogeneous due to the \pm bias yarn orientations. Triaxial weaving methods and techniques are also well developed. 3D woven fabrics have multiple layers and no delamination due to the presence of Z-fibers. However, 3D woven fabrics have low in-plane properties. 3D weaving methods and techniques are commercially available. Multiaxis 3D knitted fabrics, which have four layers and layering achieved by stitching, have no delamination and their in-plane properties are enhanced due to the \pm bias yarn layers. However, it has limitations regarding multiple layering and layer sequences. Multiaxis 3D knitting methods and techniques have been perfected. Multiaxis 3D woven fabrics have multiple layers and no delamination due to Z-fibers and enhanced in-plane properties due to the \pm bias yarn layers. Also, the layer sequence can be arranged based on end-use requirements. However, the multiaxis 3D weaving technique is at an early stage of development and needs to be fully automated. This will be a future technological challenge in the area of multiaxis 3D weaving.

Funding

This research received no specific grant from any funding agency in the public, commercial, or not-for-profit sectors.

References

- Dow MB and Dexter HB. Development of stitched, braided and woven composite structures in the ACT Program and at Langley Research Center (1985 to 1997). NASA/TP-97-206234, 1997.
- Kamiya R, Cheeseman BA, Popper P, et al. Some recent advances in the fabrication and design of three dimensional textile preforms: A review. *Composite Sci Technol* 2000; 60: 33–47.
- Ko FK and Chou TW. *Textile structural composites*. New York: Elsevier, 1989.
- Chou TW. *Microstructural design of fiber composites*. Cambridge, UK: Cambridge University Press, 1992.
- Hearle JWS. Textiles for composites. *Textile Horizons* 1994; 11: 11–15.
- Mouritz AP, Bannister MK, Falzon PJ, et al. Review of applications for advanced three dimensional fiber textile composites. *Composites Part A* 1999; 30: 1445–1461.
- Cox BN, Dadkhah MS, Morris WL, et al. Failure mechanisms of 3D woven composites in tension, compression and bending. *ACTA Metal Mater* 1993; 42: 3967–3984.
- Beyer S, Schmidh S, Maida F, et al. Advanced composite materials for current and future propulsion and industrial applications. *Adv Sci Technol* 2006; 50: 178–171.
- Yamamoto T and Hirokawa T. Advanced joint of 3D composite materials for space structure. *35th international SAMPE symposium*, Anaheim, USA, 1990, pp. 1069–1077.
- Donnet JB and Bansal RC. *Carbon fibers*. New York, USA: Marcel Dekker Inc, 1990.
- Bilisik K. Multiaxis three-dimensional (3-D) woven and braided preform unit cells and implementation of possible functional characterization for biomedical applications. *Artif Organs* 2009; 33(8): A101.
- Atkinson KR, Skourtis C and Hutton SR. Properties and applications of dry-spun carbon nanotube yarns. *Adv Sci Technol* 2008; 60: 11–20.
- Brandt J, Drechsler K and Filsinger J. Advanced textile technologies for the cost effective manufacturing of high performance composites. *RTO AVT Specialist Meeting on Low Cost Composite Structures*. Leon, Norway: RTO-MP- 069(II), 7–11 May, 2001.
- Mohamed MH. Three dimensional textiles. *Am Sci* 1990; 78: 530–541.
- Bilisik A and Mohamed MH. Multiaxis 3D weaving machine and properties of multiaxial 3D woven carbon/epoxy composites. *The 39th international SAMPE symposium*, Anaheim, USA, 11–14 April, 1994, pp. 868–881.
- Dexter HB and Hasko GH. Mechanical properties and damage tolerance of multiaxial warp-knit composites. *Composite Sci Technol* 1996; 51: 367–380.
- Mohamed MH and Bilisik AK. *Multilayered 3D fabric and method for producing*. US Patent 5465760, 1995.
- Uchida H, Yamamoto T and Takashima H. Development of low cost damage resistant composites. Muratec Murata Machinery Ltd, <http://www.muratec.net/jp> (2000). Access date: June 2010.
- Khokar N. Noobing: A nonwoven 3D fabric-forming process explained. *J Text Inst* 2002; 93(1): 52–74.
- Chen X. Technical aspect: 3D woven architectures. In: *Proceedings of the NWTexNet 2007 Conference*, Blackburn, UK, 2007.
- Bilisik K. *Three dimensional (3D) weaving and braiding*. PhD Thesis, University of Leeds, Leeds, UK, 1991.
- Bhatnagar A and Parrish ES. *Bidirectional and multiaxial fabric and fabric composites*. US Patent 7073538, 2006.
- Dow NF. Triaxial fabric. US Patent 3446251, 1969.
- Dow NF and Tranfield G. Preliminary investigations of feasibility of weaving triaxial fabrics (Doweave). *Textile Res J* 1970; 40(11): 986–998.
- Bilisik K. Multiaxis three dimensional (3D) flat woven fabric and weaving method: Feasibility of prototype tube carrier weaving. *Fibres Text East Eur* 2009; 17(6): 63–69.
- Deemey S. The new generation of carpet weaving machines combines flexibility and productivity. Technical Notes, Van de Wiele Incorporations, 2002.
- Mohamed MH and Zhang ZH. Method of forming variable cross-sectional shaped three dimensional fabrics. US Patent 5085252, 1992.
- King RW. Three dimensional fabric material. US Patent 4038440, 1977.
- Fukuta K, Nagatsuka Y, Tsuburaya S, et al. Three dimensional fabric, and method and loom construction for the production thereof. US Patent 3834424, 1974.
- Crawford JA. Recent developments in multidirectional weaving. NASA Conference Publication No. 2420, November, 1985, pp. 259–269.
- Khokar N. 3D-weaving: theory and practice. *J Text Inst* 2001; 92(2): 193–207.

32. Evans RG. Air jet machine and diagonal Z loop fabric pattern for three dimensional fabrics. US Patent 5924459, 1999.
33. Yasui Y, Anahara M and Omori H. Three dimensional fabric and method for making the same. US Patent 5091246, 1992.
34. Edgson R and Temple S. Fibre preforms for structural composite components. US Patent 5783279, 1998.
35. Jonas PJ. Method for fastening aircraft frame elements to sandwich skin panels covering same using woven fiber connectors. US Patent 4671470, 1987.
36. Abildskow D. Three dimensional woven fabric connector. US Patent 5533693, 1996.
37. Goldstein AD. Textile material. US Patent 2244835, 1939.
38. Kazumara M. Tetraxial fabric and weaving methods. European Patent 0263392, 1988.
39. Mamiliano D. Tetraxial fabric and weaving machine for its manufacture. US Patent 5351722, 1994.
40. Lida S, Ohmori C and Ito T. Multiaxial fabric with triaxial and quartaxial portions. US Patent 5472020, 1995.
41. Mood GI. Multiaxial yarn structure and weaving method. US Patent 5540260, 1996.
42. Bryn L, Islam MA, Lowery WL, et al. Three-dimensional woven forms with integral bias fibers and bias weaving loom. US Patent 6742547, 2004.
43. Nayfeh SA, Rohrs JD, Rifni O, et al. Bias weaving machine. US Patent 7077167, 2006.
44. Ruzand JM and Guenot G. Multiaxial three-dimensional fabric and process for its manufacture. International Patent WO 94/20658, 1994.
45. Kimbara M, Fukuta K, Tsuzuki M, et al. Three dimensional multi-axis fabric composite materials and methods and apparatuses for making the same. US Patent 5076330, 1991.
46. Khokar N. Woven 3D fabric material. US Patent 6338367, 2002.
47. Anahara M and Yasui Y. Three dimensional fabric and method for producing the same. US Patent 5137058, 1992.
48. Uchida H, Yamamoto T, Takashima H, et al. Three dimensional weaving machine. US Patent 6003563, 1999.
49. Bilisik K. Multiaxis 3D weaving: comparison of developed two weaving methods-tube-rapier weaving versus tube-carrier weaving and effects of bias yarn path to the preform properties. *Fibers Polym* 2010; 11(1): 104–114.
50. Bilisik K. Dimensional stability of multiaxis 3D woven carbon preform. *J Text Inst* 2010; 101(5): 380–388.
51. Bilisik K. Multiaxial three dimensional (3D) circular woven fabric. US Patent 6129122, 2000.
52. Bilisik K. Multiaxis three dimensional (3D) circular woven preforms-radial crossing weaving and radial in-out weaving: Preliminary investigation of feasibility of weaving and methods. *J Text Inst* 2010; 101(11): 967–987.
53. Wilkens C. Warp knitted ware with reinforcing thread. US Patent 4518640, 1985.
54. Naumann R and Wilkens C. Warp knitting machine. US Patent 4703631, 1987.
55. Hutson HK. Biased multilayer structural fabric composites stitched in a vertical direction. US Patent 4550045, 1985.
56. Wunner R. Apparatus for laying transverse weft threads for a warp knitting machine. US Patent 4872323, 1989.
57. Scardino FL and Ko FK. Triaxial woven fabrics: Part I Behavior under tensile, shear and burst deformations. *Textile Res J* 1981; 51(2): 80–89.
58. Schwartz P. The mechanical behavior of fabrics having three, non-orthogonal thread directions (triaxial) and the equivalence of conventional fabrics. PhD Thesis, NCSU, 1981.
59. Skelton J. Triaxial woven fabrics: Their structure and properties. *Textile Res J* 1971; 41(8): 637–647.
60. Gowayed YA and Pastore CM. Analytical techniques for the prediction of elastic properties of textile reinforced composites. *Mech Compos Mater* 1993; 28(5): 393–408.
61. Tan P, Tong L and Steven GP. Modelling for predicting the mechanical properties of textile composites-A review. *Composites Part A* 1997; 28A: 903–922.
62. Naik RA. TEXCAD – Textile composite analysis for design. NASA Contractor Report 4639, 1994.
63. Cox BN and Dadkhah MS. The macroscopic elasticity of 3D woven composites. *J Compos Mater* 1995; 29: 785–819.
64. Cox BN and Flanagan G. Handbook of analytical methods for textile composites. NASA Contractor Report 4750, 1997.
65. Pochiraju K and Chou TW. Three-dimensional woven and braided composites-I. A model for anisotropic stiffness prediction. *Polym Compos* 1999; 20(4): 565–580.
66. Verpoest I and Lomov SV. Virtual textile composites software WiseTex: Integration with micro-mechanical, permeability and structural analysis. *Compos Sci Technol* 2005; 65: 2563–2574.
67. Gu P. Analysis of 3D woven preforms and their composite properties. PhD Thesis, NCSU, College of Textiles, Raleigh, 1994.
68. Bilisik K. Multiaxis 3D woven preform and properties of multiaxis 3D woven and 3D orthogonal woven carbon/epoxy composites. *J Reinf Plast Compos* 2010; 29(8): 1173–1186.
69. Dickinson LC. Evaluation of 3D woven carbon/epoxy composites. MS Thesis, NCSU, Raleigh, USA, 1990.
70. Babcock W and Rose D. Composite preforms. *AMPTIAC Newsletter* 2001; 5(1): 7–11.