

Electric Vehicle Scheduling Considering Co-optimized Customer and System Objectives

Maigha, *Student Member, IEEE*, M. L. Crow, *Fellow, IEEE*

Abstract—Efficient electric vehicle scheduling is a multi-objective optimization problem with conflicting customer and system operator interests, especially during vehicle-to-grid implementations. Economic charging while minimizing battery degradation and maintaining system load profiles couple the interests of these two entities. This paper focuses on identifying the relationships between these objectives and proposes to use an augmented epsilon-constrain (AUGMECON) based technique to implement two-way and three-way multi-objective optimizations. The importance of using these objectives in peak-shaving and valley-filling for an aggregated (residential) EV fleet is discussed. The proposed solution provides a look-ahead strategy into effective electric vehicle scheduling by co-optimizing multiple objectives. To provide operational guidance to utilities and customers, an optimal solution may be selected from those represented by the Pareto fronts.

Index Terms—AUGMECON, battery degradation, electric vehicles, multi-objective optimization, V2G

NOMENCLATURE

Parameters	
λ^t	Electricity rate at time instant t . (\$/kWh)
ε	Positive constant of AUGMECON $\in [10^{-6} \ 10^{-3}]$
η_{ch}	Battery charging efficiency (= 0.92).
η_{dch}	Battery discharging efficiency (= 0.90).
bat_{life}	Battery lifetime in years (= 10 years or 5000 cycles).
d	Linear battery degradation cost-intercept = 6.41×10^{-6}
e_j	Equality constraint parameter.
$grid_j$	Number of gridpoints of objective.
$iter_j$	Iteration parameter.
m	Linear battery degradation cost-slope parameter = 1.59×10^{-5} .
$range_j$	Range of objective function.
t	Time instant.
ub_j	Upper bound of objective.
$B_{cap,i}$	Battery capacity of vehicle i .
C_{bat}	Battery cost in \$ (= \$300/kWh).
C_{labor}	Labor cost for battery replacement (= \$240).
CF_{max}	Capacity fade at end of life = 20%
DOD	Depth of discharge of battery at end of life.
$E_{i,req}$	Energy required for full charge for vehicle i . (kWh)
N_{veh}	Total number of vehicles.
P_{avg}	Average load demand. (kW)
$P_{ch,max}$	Maximum charging power rating $\in [1.44, 6.66]$. (kW)
$P_{ch,min}$	Minimum charging power rating (= 0) (kW)
P_{peak}	Forecasted peak load demand. (kW)
P_{res}^t	Residential load demand at time t . (kW)
$P_{dch,max}$	Maximum discharging power rating (= 0). (kW)
$P_{dch,min}$	Minimum discharging power rating $\in [-1.44, -6.66]$. (kW)

The authors are with the Department of Electrical and Computer Engineering, Missouri University of Science and Technology, Rolla, MO 65401 USA.

$t_{i,avail}$ Time available for charging vehicle i . (h)

$SoC_{i,min}$ Minimum SOC of battery of vehicle i .
 $SoC_{i,max}$ Maximum SOC of battery of vehicle i .

Variables

$x_{i,ch}^t$	Charging power of vehicle i at time t . (kW)
$x_{i,dch}^t$	Discharging power of vehicle i at time t . (kW)
$E_{\Delta t}^{dch}$	Energy discharged in Δt . (kWh)
E_{bat}^t	Energy stored in the battery at time t . (kWh)
$P_{i,veh}^t$	Vehicle i load demand at time t . (kW)
P_{sys}^t	Total system load demand at time t . (kW)
$SoC_{i,avg}^t$	Average SOC of battery of vehicle i at time t .
f_j	Objective function j .
s_j	Positive slack variable.
x	Optimization variable.
v_i^t	Binary optimization variable.
S	Solution space for variable x .

I. INTRODUCTION

COMMERCIALIZATION and adoption of electric vehicles (EV) in the automobile market has raised concerns over their uncontrolled charging demands and their impact of the present electrical power system to serve the increasing load demand efficiently. Increases in EV load may lead to network congestion, high losses, thermal stresses, and require network reinforcements, in addition to higher operating costs at peak demands. Therefore, scheduling and control of the EV load is essential for the economic operation of the power system. Vehicle-to-grid (V2G) operations of the EVs impose additional problems due to power injection into the electric grid traditionally designed for one-way power flow. Apart from the technical challenges, well designed financial models and transactive energy frameworks are required to make V2G a feasible and lucrative option [1]-[3].

Lack of widespread fast charging infrastructure, range anxiety, and higher costs of EVs influence customer choice. Additionally, relinquishing charging control to an external entity is undesirable to the customer unless on-demand availability and adequacy of the vehicle is ensured. Hence, there is a need for well-designed control and scheduling techniques that cater to customer comfort, financially motivate them, and provide incentives for V2G without compromising network or battery health. These challenges motivate the need for a multi-pronged approach to problem solution.

Past literature has studied various aspects of multi-objective optimization of electric vehicles [4]-[23] from the perspective of customer vs. the system operator. For example, in [6], annual traffic at fast charging stations was maximized, while minimizing distribution system energy losses and annual investments. In general, artificial intelligence-based methods such

as genetic algorithms (NSGA-II) or particle swarm optimization (ESPSO) have been used for determination of efficient solutions in multi-objective optimization (MOO) problems.

Most literature on multi-objective optimization study this problem from the power management perspective [9]-[12]. References [9] and [11] use an electrochemical battery model to determine optimal battery health conscious power management strategies for EVs. The detailed impacts and dynamics on load profiles and customer charging costs have not been discussed in these studies. A multi-objective health conscious charging paradigm developed in [14] coupled electro-thermal-aging model for the charging/discharging cycles and used a nonlinear battery model that did not have a specific electric vehicle application.

Investment in transportation and power infrastructure have been considered in [15]-[16]. In [15], fast and slow charging models of electric vehicles using driving profiles derived from the NHTS data were considered. The planning models seek to minimize annual investment costs and energy losses and maximize annual traffic flow using a MOEA/D algorithm that captures efficient investment in power and transportation infrastructure. Owner convenience and revenue of the service provider are considered in [16] which consider a battery-swapping infrastructure and EV ownership respectively. Neither of these studies considered V2G or battery degradation in their models.

In [17], microgrid operational costs and voltage deviations have been co-optimized in a multi-objective optimization framework using the ϵ -constraint method. Aggregated PV parking lots with active and reactive power support have been modeled without consideration of individual driving profiles. Reference [18] proposes an incentive program with lower off-peak electricity price for EV charging. A particle swarm based two-stage multi-optimal optimization strategy has been proposed and implemented to minimize load variations and system operator's financial losses. In [19], authors use an adaptive weighted sum method to maximize total utility which is defined as a linear combination of customer satisfaction, system operator profits and grid impacts. They use a regression model to find aggregated energy demand of different charging stations based on electricity price. These studies all use an aggregated EV load without consideration of V2G capability or commuter dynamics.

In [20] and [21], a 2-way multi-objective problem considering operating load variance versus charging costs and costs versus emissions have been solved using the weighted-sum and augmented ϵ -constraint methods respectively. The authors established the conflicting nature of the objectives. The former designed a local control scheme, while the latter used a centralized control approach for EV scheduling. Reference [20] used a normalizing factor based on the Nadir and Utopia points of each objective function. Despite the consideration of V2G, battery degradation was not considered in either study.

Lastly, the authors in [22] included a depreciation term to account for battery degradation in a weighted objective function. An event driven, model predictive control method has been proposed in this work to minimize user costs and to track a reference profile. A similar approach was followed

in [23] to optimize the weighted sum of four objectives using a particle swarm optimization technique. The objectives included minimizing system losses, frequency of OLTC transformer tap changing, deviation from the daily load profile, and maximizing customer satisfaction. In these studies, a fixed set of weights were used for analysis, thus Pareto solutions were not obtained.

These papers lay the groundwork to support our claim that multi-objective optimization schemes result in better scheduling strategies for electric vehicles. We bridge the gap identified in the literature by considering V2G, battery degradation, and individual driving profiles in this study. To date, a three-way MOO combining battery health, cost, and system operation has not been studied in detail. This paper bridges this gap and proposes a mathematical programming technique for the three-way MOO, thereby extending the work in [6]-[21]. In this paper, we extend these frameworks and the scheduling paradigm developed in [24] to solve 2-way and 3-way optimization problems considering customer and system perspectives. We then compare the weighted-sum approach with the augmented ϵ -constraint approach.

In this paper, a centralized EV control, optimization, and scheduling (COS) scheme is presented based on a multi-objective optimization approach that co-optimizes customer and system operator (SO) objectives. It addresses the needs of the system operator to control the peak load and that of the customer, who is financially motivated but concerned with battery life during V2G operations. The COS scheme provides a look ahead into the optimal solution choices for the available vehicle set. In real time, this may be used to guide EV scheduling directly, or indirectly through change in pricing schemes, or by providing charging choices to customers. With the development of transactive business models, parking structures/lots could participate as independent actors in energy markets.

The contributions of this paper include:

- 1) Identification of conflicting and in-line objectives for efficient EV charging.
- 2) Implementation of 2-way and 3-way multi-objective optimization for EV scheduling for a residential parking lot using augmented ϵ -constraint optimization (AUGMECON).
- 3) Co-optimization of customer and utility objectives.
- 4) Comparison between AUGMECON and weighted sum approaches in determining efficient Pareto fronts.

II. PROBLEM FORMULATION AND METHODOLOGY

The centralized COS scheme is implemented by the parking lot controller (PLC). The parking lot controller receives vehicle characteristic information (VCI) and vehicle profile information (VPI) from each vehicle as tuples: $\langle B_{i,cap}, SOC_{i,min}, SOC_{i,max} \rangle$, and $\langle t_{i,avail}, SOC_{i,avg}^0 \rangle$ respectively. After the optimization calculations, the resulting schedule and additional cost information is sent to each vehicle and the system operator. Depending on the objectives used during the optimization, information regarding cost/revenues earned during scheduling, battery degradation costs incurred,

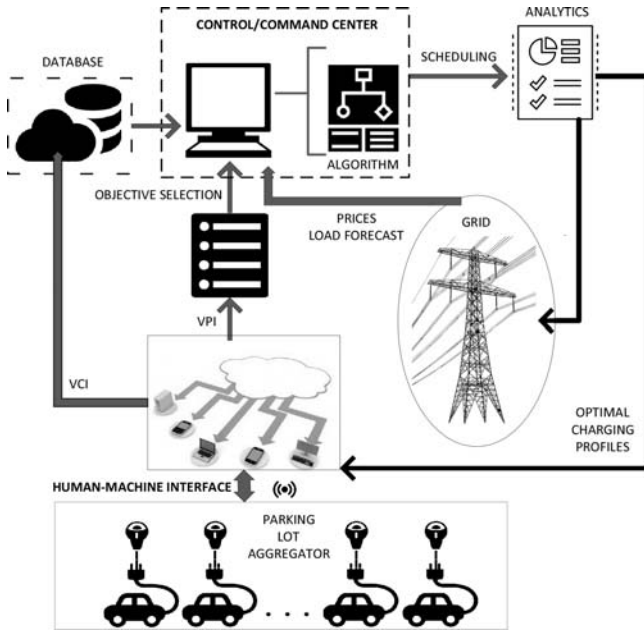

Fig. 1. Control Optimization and Scheduling Architecture for PLC

and impact on the system may be sent to the customer. The system operator may be informed of the energy available for transaction at each hour and the impacts of different schemes on the system load profiles. Therefore, the COS scheme implemented by the parking lot controller acts as a mid-layer between the customer and system operator.

A. Objective Function Modeling

This section defines the objective functions corresponding to battery degradation, customer costs/revenues, and system load profiles.

1) *Battery Degradation Cost Model (BDCM)*: Cyclic charging and discharging during V2G implementation affects the life of the automotive EV battery adversely, thus incurring costs to the customers [26]. The battery, being one of the most expensive components of the EV, needs special consideration to provide the best return on investment to the customer. Battery power fade and capacity fade have been found to be influenced by temperature, open-circuit voltage, C-rate, and depth-of-discharge (DOD) of the battery [27]. Often the effect of power fade is very small in comparison to capacity fade. Since battery degradation costs are highly non-linear functions, a simplified lifetime battery degradation cost ($\Psi^{deg}(x)$) model has been adopted from [8] and [27]. For each vehicle i at time instant t , the battery degradation cost (Ψ_i^t) is composed of two components: 1) SOC related cost $\Psi_{i,t}^{SOC}$, and 2) depth of discharge related cost $\Psi_{i,t}^{DOD}$ (1). These components are defined in (2) and (3) for all $x \in X$ where $x = \{\{x_{ch,i}^t, x_{dch,i}^t\}: i \in [1, N_{veh}], t \in [1, t_{avail}]\}$. A capacity fade of 20% at the end of a ten year lifetime of a Li-ion battery has been assumed in this study.

$$\begin{aligned} \Psi_i^{deg}(x) &= \sum_{t=1}^{t_{i,avail}} \Psi_i^t \\ &= \sum_{t=1}^{t_{i,avail}} \Psi_{i,t}^{SOC} + \sum_{t=1}^{t_{i,avail}} \Psi_{i,t}^{DOD} \end{aligned} \quad (1)$$

$$\Psi_{i,t}^{SOC} = C_{bat} \frac{m SOC_{avg,t} - d}{8760 CF_{max} bat_{life}} \quad (2)$$

$$\Psi_{i,t}^{DOD} = \frac{C_{bat} B_{cap} + C_{labor}}{bat_{life} B_{cap} DOD} E_{\Delta t}^{dch} \quad (3)$$

$$x = \begin{cases} x_{ch,i}^t, & \text{if } v_i^t=1 \text{ (charging mode)} \\ x_{dch,i}^t, & \text{if } v_i^t=0 \text{ (discharging mode)} \end{cases} \quad (4)$$

where

$$SOC_{i,avg}^{t+1} = SOC_{i,avg}^t + \frac{x_{i,ch}^t + x_{i,dch}^t}{B_{cap}} \quad (5)$$

$$E_{\Delta t}^{dch} = E_{t-1}^{bat} - E_t^{bat} \quad (6)$$

A binary variable v_i^t is introduced in (4) to ascertain whether the battery is in either a charging or discharging mode at each time instance t for each vehicle i . The $SOC_{i,avg}^{t+1}$ is calculated using the net energy added to the battery during that time interval, as in Eq. (5). Since the degradation cost due to depth of discharge is associated with the V2G mode, Eq. (6) is true only for discharging operations.

The first objective function is defined as:

$$\arg \min_x f_1(x) = \sum_{i=1}^{N_{veh}} \Psi_i(x) \quad (7)$$

which seeks to minimize the battery degradation costs across all vehicles.

2) *Customer Charging-Discharging Cost Model (CCDM)*: Time-of-use (TOU) rates are being offered by utilities as a part of a demand-response initiative to motivate load shifting by customers. EV owners are being provided with special time-of-use rates to schedule vehicle charging during valley periods, typically at night [28]. The resulting decrease in electric bills serves as financial incentive to the customer. Similarly, a customer might earn higher revenues by participating in V2G energy transactions by selling energy during peak hours. In this study, we assume a net-metering policy for charging and discharging the EV at the time-of-use prices offered by the utility (λ_t). The total costs incurred/revenues earned by the customer are represented by Ψ_i^{rev} . Equations (8) and (9) provide the mathematical formulation and definition of the objective respectively.

$$\Psi_i^{rev}(x) = \sum_{t=1}^{t_{i,avail}} \lambda_t \left(\frac{x_{ch,i}^t}{\eta_{ch}} - x_{dch,i}^t \eta_{dch} \right) \quad (8)$$

$$\arg \min_x f_2(x) = \sum_{i=1}^{N_{veh}} \Psi_i^{rev}(x) \quad (9)$$

3) *Valley-filling Model (VFM)*: Uncoordinated EV charging may cause a substantial increase in peak demand. This is economically undesirable due to 1) bringing up of costly generators to serve the load and 2) increase in network stresses requiring infrastructural reinforcements. Valley-filling leads to shifting of load demand to create a more level profile without increasing the peak demand, thus serving the interests of the system operator. Valley filling minimizes the deviation between instantaneous and the average load. EV scheduling during lightly loaded valley periods is expected to improve the load factor of the system. It is defined as:

$$\arg \min_x f_3(x) = \sum_{t=1}^{24} (P(x)_{sys}^t - P_{avg})^2 \quad (10)$$

$$P(x)_{sys}^t = P_{res}^t + \sum_{i=1}^{nVeh} P_{i,veh}^t \Delta t \quad \forall t \quad (11)$$

where

$$P_{i,veh}^t = \frac{x_{ch,i}^t}{\eta_{ch}} - x_{dch,i}^t \eta_{dch} \quad (12)$$

The total system load at time t is calculated in (11) as the sum of residential load and total vehicle load at that time instant. The total vehicle load is the net EV demand (*charging-discharging*) on the system at time t . A 1 hour time step (Δt) has been considered in this study.

B. Vehicle and System Constraints

Vehicle scheduling is a constrained optimization problem. Due consideration must be given to customer convenience (vehicle arrival and departure times, SOC requirements), charger limitations (maximum input/output power), battery dynamics (minimum/maximum SOC), and system peak loads. The following constraints complete the problem definition. For each vehicle i and time instant t , the following constraints hold:

$$P_{ch,min} \leq x_{i,ch}^t \leq P_{ch,max} \quad (13)$$

$$P_{dch,min} \leq x_{i,dch}^t \leq P_{dch,max} \quad (14)$$

$$SoC_{i,min} \leq SoC_{i,avg}^t \leq SoC_{i,max} \quad (15)$$

$$\sum_{t=1}^{t_{i,avail}} (x_{i,ch}^t - x_{i,dch}^t) \Delta t = E_{i,req} \quad (16)$$

$$\sum_{i=1}^{nVeh} \left(\frac{x_{ch,i}^t}{\eta_{ch}} - x_{dch,i}^t \eta_{dch} \right) \leq (P_{peak} - P_{res}^t) \quad (17)$$

Equations (13) and (14) define the minimum and maximum charging and discharging power limits respectively and $SoC_{i,avg}^t$ defined in (5) is constrained in (15). Constraint (16) ensures that the battery is fully charged at the end of the charging period. To constrain the peak load to its original value (residential peak load demand), (17) may be used.

Note that any change in the driving or parking patterns between predicated and actual behavior, would affect the scheduling schemes and would require a stochastic analysis. Eventually, with higher penetrations of EVs, their impact on

real-time pricing and market dynamics would also become prominent. These factors would have an impact on the charging approach, but these considerations are currently out of the scope of this study.

C. Multi-objective optimization procedure

Unlike mathematical programming with a single objective, the objectives in multi-objective optimization may not be optimized simultaneously. The concept of a single optimal solution is therefore replaced by the most preferred solution under a Pareto optimality or efficiency conditions. A solution is a Pareto optimal if its improvement cannot be accomplished without deteriorating the performance of at least one of the other objectives. An effective MOO technique seeks to find these multiple trade-off solutions from which one may be chosen based on a user-defined set of higher-level information (Fig. 2).

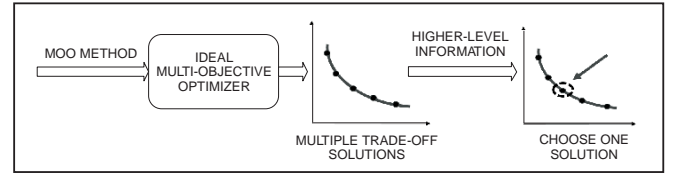

Fig. 2. Illustration of multi-objective optimization method

The original MOO problem is:

$$\begin{aligned} \min & (f_1(x), f_2(x), \dots, f_p(x)) \\ \text{subject to} & x \in S \end{aligned}$$

Two classical methods for solving MOO have been discussed in the following sections.

1) *Weighted Sum Method*: In the weighted-sum MOO method, the problem is designed as an aggregated convex combination of the objectives. Each objective is multiplied by a weighting factor and added to transform the multi-objective problem into a single objective. In order to account for the bias due to the scale of one objective over the other, the objective functions may be normalized. Generally, this normalizing factor is the corresponding optimum function value (f_i^*). The aggregated function is given as:

$$\min_x f_{weighted} = w_1 (f_1(x)/f_1^*) + w_2 (f_2(x)/f_2^*) \quad (18)$$

where w_1 and w_2 are the weights for functions f_1 and f_2 respectively and $w_1 + w_2 = 1$. The functions f_1 and f_2 have been normalized using their optimal values f_1^* and f_2^* , obtained by performing the optimizations individually. Despite its simplicity in solving convex problems, the weighted-sum method does not guarantee a uniformly distributed set of Pareto-optimal solutions for a uniformly distributed set of weights. Secondly, it cannot find solutions in the non-convex solution space. These drawbacks can be overcome by using the AUGMECON method.

2) *Augmented ϵ -constraint method*: The ϵ -constraint method seeks to optimize one of the objectives while varying the others within a restricted range specified by a pay-off table. The AUGMECON method is an improvement on the traditional ϵ -constraint method [29] for performing multi-objective optimization. The advantage of AUGMECON over the classical weighted-sum approach is 1) its ability to find solutions in non-convex regions, and 2) finding different Pareto-optimal solutions by varying the value of ϵ , which thus dictates the solution set to some extent. As the number of objectives increase, the user is required to provide more information. The AUGMECON method for solving the MOO for vehicle scheduling is described below:

$$\arg \min_{x, s_2, s_3} \left(\underbrace{f_3(x)}_{\text{term 1}} - \underbrace{\epsilon(s_2 + s_3)}_{\text{term 2}} \right) \quad x \in S \quad (19)$$

subject to:

$$f_j(x) + s_j = e_j \quad \forall j \in [1, 2] \quad (20)$$

where

$$e_j = ub_j - \frac{(iter_j \times range_j)}{grid_j} \quad (21)$$

A $p \times p$ payoff table defining the range of each objective is introduced using the lexicographic method described in [29]. Each row j of the payoff table corresponds to objective f_j with its optimal value f_j^* as the j^{th} column entry and values of all other $p - 1$ objectives calculated at x^{j*} at each corresponding column. One of the p objectives is then used as the optimization function (key objective) along-with the other $p - 1$ functions introduced as equality constraints, varied within the maximum and minimum range defined by the payoff table (Fig. 3).

TABLE I
PAYOFF TABLE FOR THE OBJECTIVE FUNCTIONS

	f_1 (\$) (BDCM)	f_2 (\$) (CCDM)	f_3 (VFM)
f_1^*	0.1634	156.2275	6.7345×10^4
f_2^*	282.8085	20.5376	8.5883×10^4
f_3^*	295.7163	86.6299	1.3921×10^3
Range	295.553	135.6899	15.486×10^4

In Table I, row 1 corresponds to the result of optimizing battery degradation costs with its optimal value in column 1. The values of charging cost and valley filling, calculated at its minimum argument ' x ', are then entered in columns 2 and 3 respectively. The range of each objective is calculated as the difference between its maximum and minimum values. Once the range is defined, the gridpoints ($grid_j$) give the number of sections/blocks this range is divided into. The ratio $\frac{range_j}{grid_j}$ defines the step size through which e_j decrements at every iteration as each constrained objective moves from its maximum value to its minimum value. Therefore, a sub-problem P is defined corresponding to each value of parameter e_j (19)-(21).

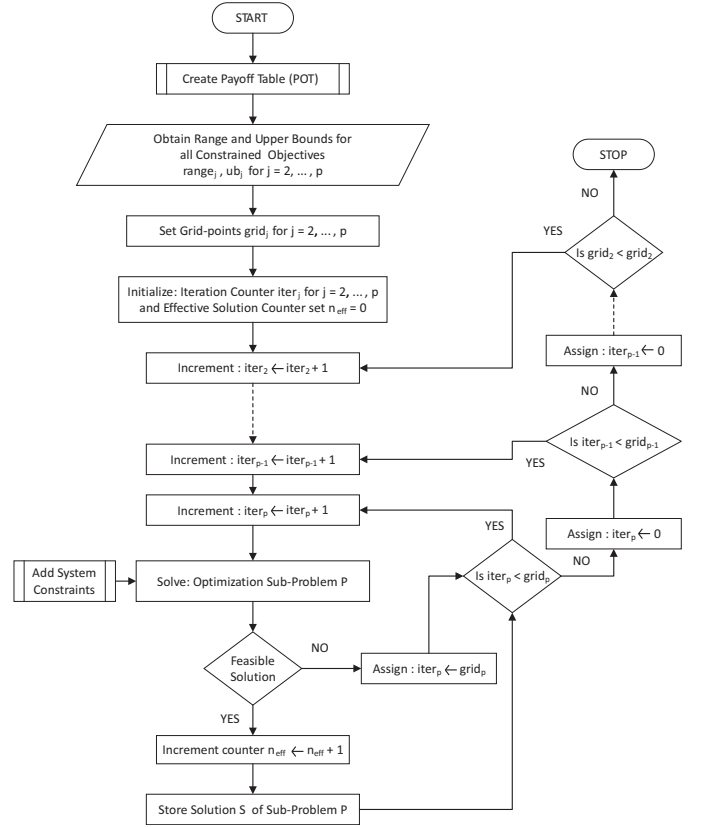

Fig. 3. Flowchart for the AUGMECON method for MOO

In a 3-way MOO using the AUGMECON method, valley filling (f_3) was chosen as the key objective with the addition of term 2 of (19) for two reasons:

- 1) It results in a flat load profile
- 2) It is computationally easier to handle linear functions as constraints than quadratic functions

Objectives f_1 and f_2 are then entered as equality constraints according to (20) and (21). The value of ϵ in (19) is set at 10^{-6} . Twenty and twenty-five gridpoints ($grid_j$) are considered in the 2-way and 3-way MOO cases respectively. In the 2-way case, the iterate $iter_j$ varies between 1 and 20 leading to 20 sub-problems. A step size of 0.05 was used in the weighted-sum approach for updating the weights, thus resulting in 20 weight combinations. In the 3-way case, 5 gridpoints for each of the $p - 1 = 2$ objectives resulted in 25 sub-problems to be solved. An increase in computational complexity is encountered with an increase in the number of gridpoints in solving the sub-problems. Here, a parallel programming approach could provide better computational speeds.

III. SIMULATION RESULTS AND OBSERVATIONS

A typical summer day load profile and a 3-tier time-of-use pricing (Table II) were obtained from Pacific Gas and Electric (PGE), and subsequently scaled up for simulating the residential parking lot [30]. The PGE rates were tiered for better accuracy using the clustering method proposed in [31]. A 60% EV penetration in a 245 house residential complex is assumed for which the driving profiles were obtained from

the NHTS database [32]. A modified IEEE 34 bus system has been used in this study [33]. Vehicles are randomly distributed in the ratio of load at the nodes (Fig. 4). Furthermore, the methodology proposed in [33] was adopted for battery and charger assignments which included 5 battery sizes and type I and II chargers [34]. The aggregated effect of the vehicles on the system is considered due to the absence of geo-spatial distribution of the vehicles in the distribution system.

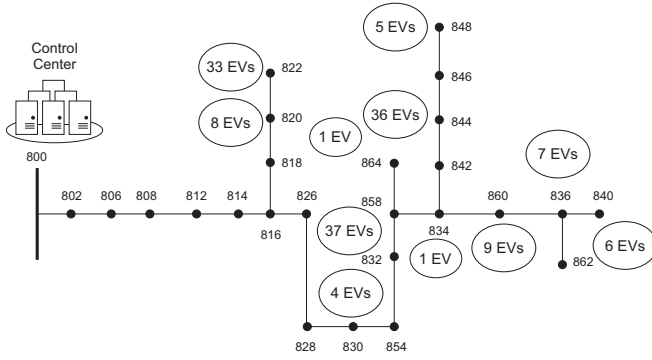

Fig. 4. Modified IEEE-34 bus system [33]

TABLE II
TOU RATE STRUCTURE [30]

Rate Type	Energy Charge ($\text{\$/kWh}$)		
	TOU 2-Tier	16.94	26.5425
TOU 3-tier	1:00-12:00	13:00-24:00	
	13.101	20.779	32.306
	2:00-10:00	11:00-13:00	14:00-20:00
		21:00-1:00	

The Battery Degradation Cost Model and the Customer Charging-Discharging Cost Model have been solved as mixed integer linear problems. Due to the quadratic nature of the valley filling objective, the valley filling and AUGMECON models have been solved as quadratic mixed integer problems. The IBM-ILOG CPLEX software platform [35] was used to generate the initial guess for the relaxed version of each problem (LP and QP respectively) followed by final solution using GUROBI optimization package [36].

A. Case Definitions

The following cases have been used to test the viability of MOO approach:

Base case with no optimization

- *Case 0*: Uncoordinated EV charging

Single objective function optimizations

- *Case 1*: Customer focused: Minimizing customer charging cost (or maximizing revenues) in V2G/G2V modes (CCDM)
- *Case 2*: Customer focused: Minimizing battery degradation cost in V2G/G2V modes (BDCM)
- *Case 3*: System focused: Valley filling in V2G/G2V modes (VFM)

Multiple objective function optimizations with two objective functions

- *M200 1*: Battery degradation vs. Customer cost/revenues
- *M200 2*: Valley filling vs. Customer cost/revenues
- *M200 3*: Valley filling vs. Battery degradation

Multiple objective function optimizations with three objective functions

- *M300*: Battery degradation vs. Customer cost/revenues vs. Valley filling

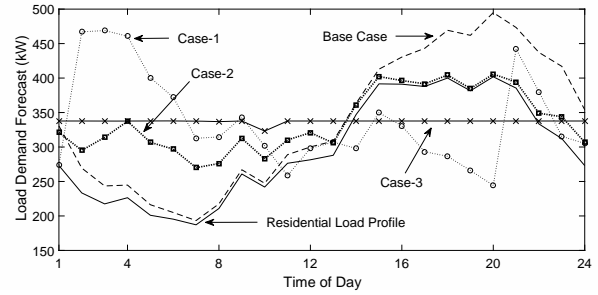

Fig. 5. Optimal load demand forecast under individual objectives

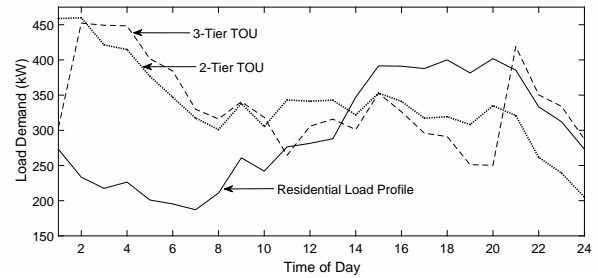

Fig. 6. System load profiles with 2-tier and 3-tier TOU rates

TABLE III
TOTAL CUSTOMER COST

Customer Cost	2-Tier TOU	3-Tier TOU
		\$102.44

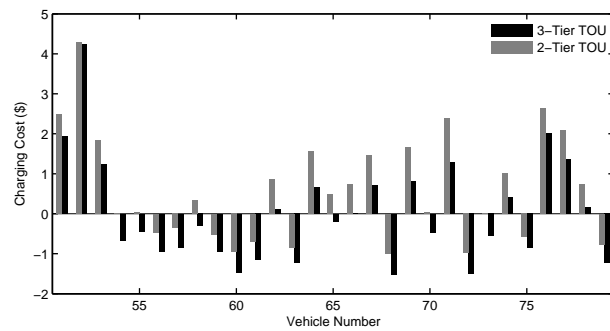

Fig. 7. Charging costs under the two pricing schemes for a population sample

Figure 5 shows the resulting load profiles for cases 1-3 with independent implementation of the three objective functions. Charging/discharging profiles for electric vehicle load has been shown in Fig. 9 The following observations can be made:

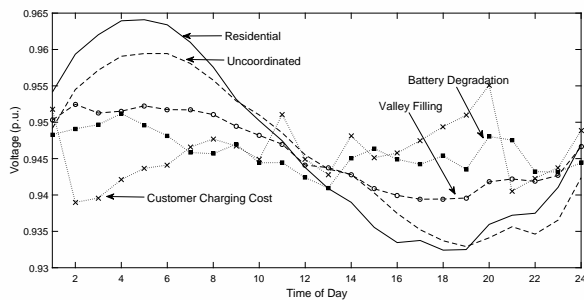

Fig. 8. Voltage profile of Node 844 under different schemes

TABLE IV
SYSTEM LOSSES FOR INDIVIDUAL CASES (KW)

Residential	Case 0	Case 1	Case 2	Case 3
511.266	600.790	579.415	581.243	576.718

- (Base case) Uncoordinated charging results in an inadvertent increase in peak demand during evening hours and leaves the valley period during early morning unchanged.
- (Case 1: Minimizing customer charging cost) Implementation of time-of-use rates (without imposing system-level constraints) leads to two peaks: one in late evening and another in early morning. Furthermore, the resulting peaks are higher than the original system peak demand. Using the 2-tier TOU prices, one additional peak emerges on application of off-peak pricing (Fig. 6). 2-tier TOU results in higher costs to the customer in comparison to 3-tier pricing (Fig.7). In such situations, adaptive real-time pricing strategies would be required to alleviate these outcomes.
- (Case 2: Minimizing battery degradation cost) Avoiding battery degradation costs results in limited V2G operations and peak shaving does not occur since the load profile closely follows the residential load demand during peak hours. Vehicles charge during primarily during the valley period. Little is gained by this approach except moderate improvement in the load factor.
- (Case 3: Valley filling) V2G and G2V operations in the valley filling mode result in a nearly flat load profile. This is the most desirable load profile and is independent of the effect of pricing structure.
- Figure 9 shows that electric vehicles undergo deeper charge/discharge cycles in Case 1 followed by Case 3 and Case 2.
- The voltage profiles at system nodes follow the trends shown in Fig. 8. It can be argued that when using the multi-objective optimization scheme, the resulting profiles would remain bounded between the voltage traces for the corresponding fitness functions.
- Table IV shows that constrained charging results in lower system losses in comparison to the unconstrained case. Lowest losses were observed during valley filling. Implementation of multiple objectives would bound the system losses within the limits shown in the table.

Fig. 10 depicts the battery degradation costs and customer

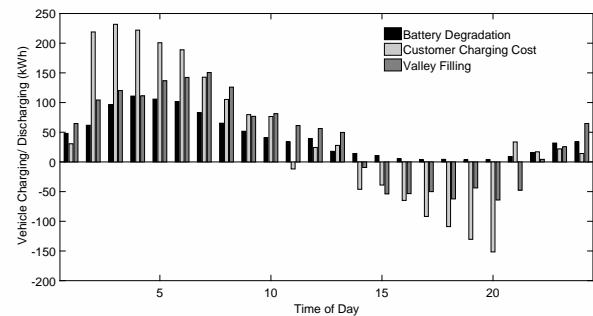

Fig. 9. Optimal EV charging/discharging profiles under individual objectives

daily costs/revenues during V2G operations for each vehicle. The x -axis represents individual vehicles. This figure indicates that battery degradation costs and V2G revenues conflict with each other. Higher revenues come at the expense of increased battery degradation costs. This outcome therefore suggests that there exists a “trade-off” or Pareto front relationship between these two objectives. This relationship is explored further through two-way multi-objective optimization.

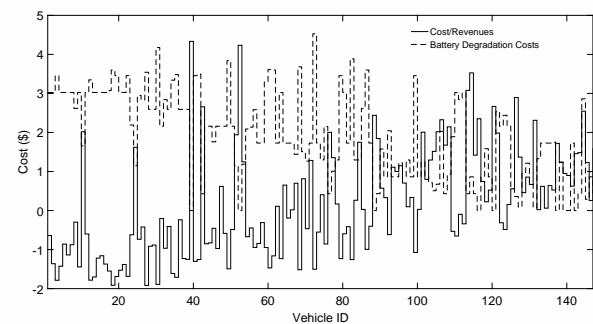

Fig. 10. Comparison of battery degradation costs vs Charging Costs/Revenues for a sample set.

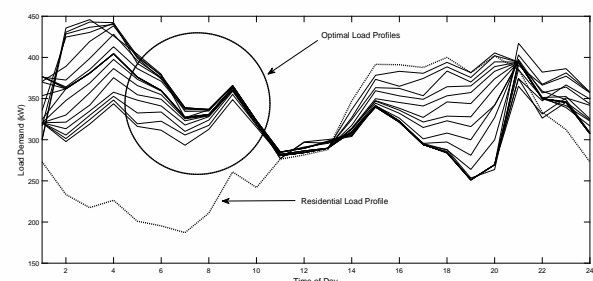

Fig. 11. Load profiles for 2-way MOO with charging cost vs. battery degradation

B. Two-way multi-objective optimization

Figures 11-15 show the load profiles and Pareto fronts for cases M2OO 1, M2OO 2, and M2OO 3. The resulting system load profiles provide insights into the variation of the optimal load demand forecast under the specified conditions. Results of the two MOO methods discussed in Section II-C have been shown in the Pareto fronts in Figs. 12, 14, and 15. The following observations can be made:

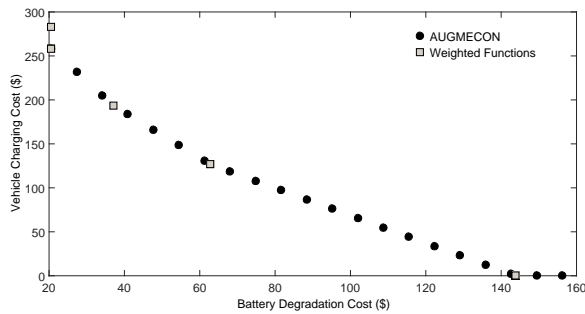

Fig. 12. Pareto front (customer charging cost/revenue vs. battery degradation cost)

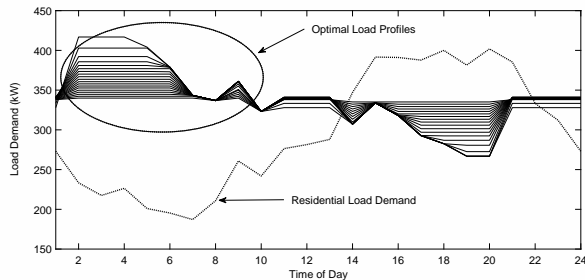

Fig. 13. Load profiles for 2-way MOO with charging cost vs. valley filling

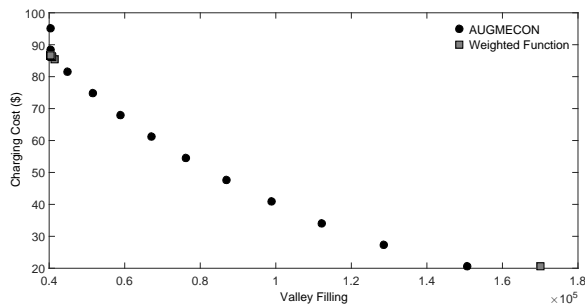

Fig. 14. Pareto front (customer charging cost/revenue vs. valley filling)

- (M2OO 1: Battery degradation vs. Customer cost/revenues): These two models are in conflict with each other as illustrated in Fig. 12. Both the AUGMECON and weighted function approach result in the same Pareto front. Therefore, the Pareto front allows the customer to select the operating condition that weighs financial profits against losses attributed to battery health, leading to any number of different load profiles based on the weighting selected. Fig. 11 illustrates the range of possible load profiles.
- (M2OO 2: Valley filling vs. Customer cost/revenues): Minimizing Charging Cost (Case 1) uses the low price tier to charge most vehicles and uses the high price tier to earn profits through V2G operation. This distorts the load profile as shown in Case 1 in Fig. 5. Since the Case 1 is undesirable to the system operator, the valley filling objective tries to balance the charge/discharge operations. Therefore, the customer charging cost/revenues model and valley filling model conflict with each other (Fig. 13). The Pareto front in Fig. 14 provides the system

operator and customer with the capability to reach a mutual consensus by selection of optimal operating criteria. Note that the AUGMECON and the weighted function approach both give the same Pareto front.

- (M2OO 3: Valley filling vs. Battery degradation) Valley filling and battery degradation both limit the V2G operations. While the former approach levelizes the load profile, the latter follows the initial residential load profile during peak hours. Fig. 15 shows the optimal operating points as the battery degradation costs are varied within the *POT* range. There is a slight Pareto-like behavior when there is a heavy weighting towards valley filling and it dominates (approaching Case 2). Battery degradation costs were found to be higher when valley filling was implemented alone. Cyclic discharging during peak hours to flatten the load profile results in an increase in battery degradation costs comparatively.

Note that in all cases, the weighted-sum method does not provide uniformly distributed solutions, but the solutions for both the weighted sum and AUGMECON techniques lie within the same range. The AUGMECON methods provides a uniform Pareto front and is therefore better suited for decision making.

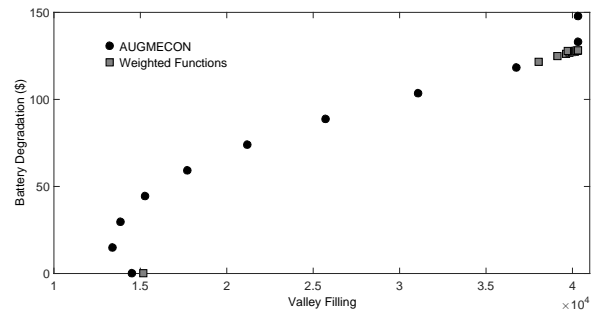

Fig. 15. Optimal solutions for battery degradation costs vs. valley filling.

C. Three-way multi-objective optimization

The results in section III-B show that there are two pairs of conflicting objectives and one pair of in-line objectives. As valley filling and battery degradation increase, customer charging costs decrease. Figs. 16 and 17 show the load profile and Pareto front as a result of performing a 3-way multi-objective optimization on battery degradation costs, customer charging costs, and valley filling objectives.

The information in the Pareto front can provide the system operator with the tools to design effective incentive plans to motivate the customers. Consequently, the system integrity may be preserved while providing financial benefits to the customers through V2G operations. Weighing customer benefits against the system requirements can provide better solutions to the EV scheduling problem. Moreover, the impacts of different pricing structures and driving profiles on customer profits and battery health may be used to educate the customer. Furthermore, efficient charging practices may be suggested for their benefit, thus improving customer engagement. A multi-objective optimization approach provides an efficient

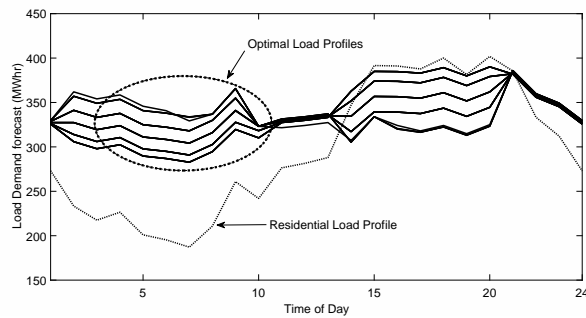

Fig. 16. Load profiles for 3-way multi-objective optimization

technique to understand these dynamics and formulate plans accordingly.

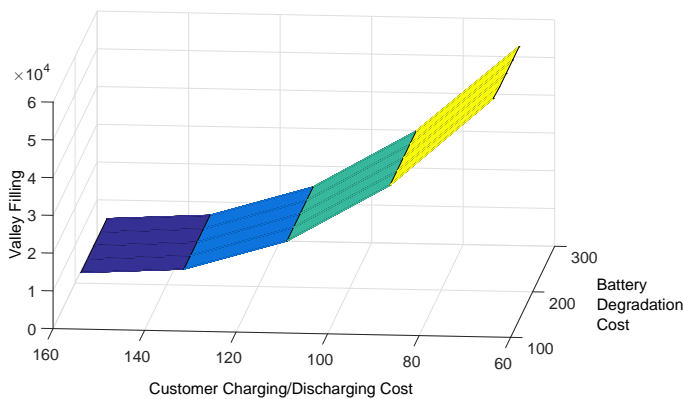

Fig. 17. Optimal solutions for battery degradation costs vs. valley filling.

IV. CONCLUSION

In this paper, the dynamics between customer and system objectives have been identified and investigated. An AUGMECON based multi-objective optimization methodology has been implemented to identify co-optimal solutions for the benefit of these two entities. A customer's financial motives and a system operator's network-based concerns have been leveraged for this purpose. A comparison between AUGMECON and weighted-sum approach establishes the superiority of the former in finding uniformly distributed solutions. The day-ahead centralized scheduling scheme would provide information to the customer and system operator to make informed decisions. The inadequacy of single objectives in proposing mutually beneficial and efficient multi-objective optimization-based control and scheduling schemes has been established.

REFERENCES

- [1] W. Kempton and J. Tomic, "Vehicle-to-grid power implementation: From stabilizing the grid to supporting large-scale renewable energy," *J. Power Sources*, vol. 144, no. 1, Jun. 2005.
- [2] M. S. ElNozahy and M. M. A. Salama, "A Comprehensive Study of the Impacts of PHEVs on Residential Distribution Networks," *IEEE Tran. Sustainable Energy*, vol. 5, no. 1, Jan. 2014.
- [3] W. Kempton and J. Tomic, "Vehicle-to-grid power fundamentals: Calculating capacity and net revenue," *Journal of Power Sources*, vol. 144, no. 1, pp. 268-279, 2005.
- [4] W. Yao et al., "A Multi-Objective Collaborative Planning Strategy for Integrated Power Distribution and Electric Vehicle Charging Systems," *IEEE Trans. Power Systems*, vol. 29, no. 4, pp. 1811-1821, July 2014.
- [5] H. Li, C. Zheng, X. Zhang, X. Chen and X. Chang, "Research on multi-objective optimization coordination of plug-in hybrid electric vehicle and distributed generation," *5th International Conference on Electric Utility Deregulation and Restructuring and Power Technologies (DRPT)*, Changsha, 2015, pp. 2608-2613.
- [6] J. Ning, Y. Tang and W. Gao, "A hierarchical charging strategy for electric vehicles considering the users' habits and intentions," *2015 IEEE Power & Energy Society General Meeting*, Denver, CO, 2015, pp. 1-5.
- [7] H. Xiao, W. Pei, Y. Yang, H. Qu, Z. Qi and L. Kong, "Multi-objective optimal operation of micro-grid with plug-in electric vehicles," *(ITEC Asia-Pacific), 2014 IEEE Conf. and Expo*, Beijing, 2014, pp. 1-5.
- [8] J. Tan and L. Wang, "Integration of Plug-in Hybrid Electric Vehicles into Residential Distribution Grid Based on Two-Layer Intelligent Optimization," *IEEE Trans. on Smart Grid*, vol. 5, no. 4, pp. 1774-1784, July 2014.
- [9] R. M. Patil, J. C. Kelly, Z. Filipi and H. K. Fathy, "A Framework for the Integrated Optimization of Charging and Power Management in Plug-in Hybrid Electric Vehicles," *IEEE Trans. Vehicular Technology*, vol. 62, no. 6, pp. 2402-2412, July 2013.
- [10] S. J. Moura, J. L. Stein and H. K. Fathy, "Battery-Health Conscious Power Management in Plug-In Hybrid Electric Vehicles via Electrochemical Modeling and Stochastic Control," *IEEE Trans. on Control Systems Technology*, vol. 21, no. 3, pp. 679-694, May 2013.
- [11] S. Bashash, S. J. Moura, J. C. Forman, H. K. Fathy, "Plug-in hybrid electric vehicle charge pattern optimization for energy cost and battery longevity," *Journal of Power Sources*, vol. 196, no. 1, pp. 541-549, January 2011.
- [12] S. J. Moura, D. S. Callaway, H. K. Fathy and J. L. Stein, "Tradeoffs between battery energy capacity and stochastic optimal power management in plug-in hybrid electric vehicles," *Journal of Power Sources*, vol. 195, no. 9, pp. 2979-2988, May 2010.
- [13] I. Unda, P. Papadopoulos, S. Skarvelis-Kazakos, L. M. Cipcigan, N. Jenkins, and Ed. Zabala, "Management of electric vehicle battery charging in distribution networks with multi-agent systems," *Electric Power Systems Research*, vol. 110, pp. 172-179, 2014.
- [14] H. Perez, X. Hu, S. Dey and S. Moura, "Optimal Charging of Li-Ion Batteries with Coupled Electro-Thermal-Aging Dynamics," *IEEE Trans. on Vehicular Technology*, vol. PP, no.99, pp.1-1, March 2017.
- [15] S. Wang et al., "A stochastic collaborative planning approach for electric vehicle charging stations and power distribution system," *2016 IEEE Power and Energy Society General Meeting (PESGM)*, Boston, MA, 2016, pp. 1-5.
- [16] L. Ming, J. Liu, X. Duan, X. Han, D. Yu and H. Diao, "Electric vehicle charge-swap station multi-objective planning optimization," *2014 IEEE PES Asia-Pacific Power and Energy Engineering Conference (APPEEC)*, Hong Kong, 2014, pp. 1-5.
- [17] T. Shekari, S. Golshannavaz, F. Aminifar, "Techno-Economic Collaboration of PEV Fleets in Energy Management of Microgrids," *IEEE Trans. on Power Systems*, vol. PP, no.99, pp.1-1, December 2016.
- [18] Q. Kang, S. Feng, M. Zhou, A. C. Ammari and K. Sedraoui, "Optimal Load Scheduling of Plug-In Hybrid Electric Vehicles via Weight-Aggregation Multi-Objective Evolutionary Algorithms," *IEEE Trans. on Intelligent Transportation Systems*, vol. PP, no.99, pp.1-12, May 2017.
- [19] C. Luo, Y. F. Huang, V. Gupta, "Stochastic Dynamic Pricing for EV Charging Stations with Renewables Integration and Energy Storage," *IEEE Trans. on Smart Grid*, vol. PP, no.99, pp.1-1, April 2017.
- [20] J. Garca-Villalobos, I. Zamora, K. Knezovi and M. Marinelli, "Multi-objective optimization control of plug-in electric vehicles in low voltage distribution networks," *Applied Energy*, vol. 180, pp. 155-168, October 2016.
- [21] A. Zakariazadeh, S. Jadid, P. Siano, "Multi-objective scheduling of electric vehicles in smart distribution system," *Energy Conversion and Management*, vol. 79, pp. 43-53, March 2014.
- [22] A. D. Giorgio, F. Liberati and S. Canale, "Electric vehicles charging control in a smart grid: A model predictive control approach," *Control Engineering Practice*, vol. 22, pp. 147-162, January 2014.
- [23] J. Yang, L. He and S. Fu, "An improved PSO-based charging strategy of electric vehicles in electrical distribution grid," *Applied Energy*, vol. 128, pp. 82-921, September 2014.
- [24] Maigha and M. L. Crow, "Cost-Constrained Dynamic Optimal Electric Vehicle Charging," *IEEE Tran. on Sustainable Energy*, DOI: 10.1109/TSSTE.2016.2615865.

- [25] Maigha and M. L. Crow, "Economic and Battery Health Conscious Vehicle-to-Grid Electric Vehicle Operation," Proceedings of the *ISGT North America*, 2016.
- [26] C. Kong, I. S. Bayram and M. Devetsikiotis, "Revenue Optimization Frameworks for Multi-Class PEV Charging Stations," *IEEE Access*, vol. 3, pp. 2140-2150, 2015.
- [27] A. Hoke, A. Brissette, K. Smith, A. Pratt and D. Maksimovi, "Accounting for Lithium-Ion Battery Degradation in Electric Vehicle Charging Optimization," *IEEE Journal of Emerging and Selected Topics in Power Electronics*, vol. 2, no. 3, pp. 691-700, Sept. 2014.
- [28] (2016, Oct.) SDGE Website. [Online]. Available: <http://www.sdge.com/clean-energy/ev-rates>
- [29] G. Mavrotas, "Effective implementation of the ϵ -constraint method in multi-objective mathematical programming problems," *Appl. Math. Comput.*, vol. 213(2), pp. 455465, 2009.
- [30] (2015, Oct.) PGE website. [Online]. Available: <http://www.pge.com/en/mybusiness/save/energymanagement/index.page>
- [31] Maigha and M. L. Crow, "Clustering-based methodology for optimal residential time of use design structure," *North American Power Symposium*, pp. 1-6, 7-9 Sept. 2014.
- [32] (2014, Aug.) 2009 National Household Travel Survey. [Online]. Available: <http://nhts.ornl.gov>
- [33] Maigha and M. L. Crow, "Economic Scheduling of Residential PHEV Charging," *Energies*, vol.7, pp. 1876-1898, March 2014.
- [34] (2016, Oct.) SAE website. [Online]. http://www.sae.org/events/gim/presentations/2013/pev_charging_standards_status.pdf
- [35] (2015, Aug.) IBM Corp., ILOG CPLEX 12.6. [Online]. Available: https://www-304.ibm.com/ibm/university/academic/pub/page/software_all
- [36] (2015, Aug.) Gurobi Optimization, Inc., "Gurobi Optimizer Reference Manual 6.5." [Online]. Available: <http://www.gurobi.com>

Maigha received the B.Tech (2002) degree in Electrical Engineering from GBPUAT, Pantnagar, Uttaranchal, India. She worked as an Assistant Software Engineer for 2.7 years at TCS, India. She is currently pursuing her PhD degree in electrical engineering at Missouri University of Science & Technology, Rolla, USA. Her research interest is in the area of power systems, renewable energy, demand response and electric vehicles.

M. L. Crow (S'83–M'90–SM'94–F'10) received the B.S.E. degree from the University of Michigan, Ann Arbor, and the Ph.D. degree from the University of Illinois, Urbana/Champaign. She is the F. Finley Distinguished Professor of Electrical Engineering at the Missouri University of Science & Technology. Her research interests include computational methods for dynamic security assessment and the application of power electronics in bulk power systems.