

# Stray losses in power transformer tank walls and construction parts

Lenart Kralj, Damijan Miljavec

**Abstract**—The article discusses the eddy current losses generated in a transformer tank walls and other electrically conductive construction parts. The losses are related to the magnetic leakage fields. A time harmonic 3D finite element method is used to compute the magnetic leakage field in the case of nominal load condition of the power transformer. The indirect measuring procedure based on the short circuit method was carried out on many different power transformer designs to validate the simulation results.

**Index Terms**—Power transformer, stray losses, eddy current losses, finite element method, surface impedance.

## I. INTRODUCTION

The paper deals with eddy current losses due to leakage magnetic fields, which occur in the conductive parts of power transformer, such as tank walls, yoke clamps and other construction parts. The 3D geometric model of power transformer was made and linked with finite element method. The time harmonic analyze is used to investigate the discussed problem. On this basis, we calculated the leakage magnetic field around the three phase primary and secondary coils at nominal current loadings. And further, the eddy current losses in transformer construction parts were computed. The analysis was conducted on a number of previously measured power transformers. In this way we verify and validate the accuracy of the calculation method and final results.

## II. POWER LOSSES IN TRANSFORMER

Power transformer is the electrical machine by far with the highest efficiency, more than 99%. However, producers want to achieve even higher efficiency and thus to become more competitive in the market of power transformers. At this stage it is the most important to calculate the power transformer performances as accurately as possible, and that they are not just the results of assessment of, for example, losses of a similar transformer. Accurate calculations of, for example, stray losses of a power transformer based on numerical model may also improve transformer structure in terms of reduced losses and increased overall efficiency [6-9].

The stray losses in the power transformer are composed of additional losses in windings and of losses which are originated in transformer's construction parts (Fig. 1). The losses in the windings are the subject to a power and voltage level of the power transformer. These losses can not be

significantly reduced, except by increasing the cross-section of the conductors. This would mean bigger and even more expensive power transformer. In addition to Joule losses, due to resistance of the transformer windings there are so called additional eddy current losses which occur in the windings. Their origin is in leakage magnetic fields to which the windings are exposed to. The additional eddy current losses in the windings for different types of power transformers are analyzed in [5].

These additional losses have a smaller share of all losses in the transformer, but they are a substantially more difficult to calculate. The additional losses in the windings and in the construction, due to leakage magnetic field can not be separately measured. The additional losses in the windings can be accurately calculated using two-dimensional finite element model of the transformer. For an accurate calculation of stray losses in the construction parts the 3D finite element model of the power transformer must be used.

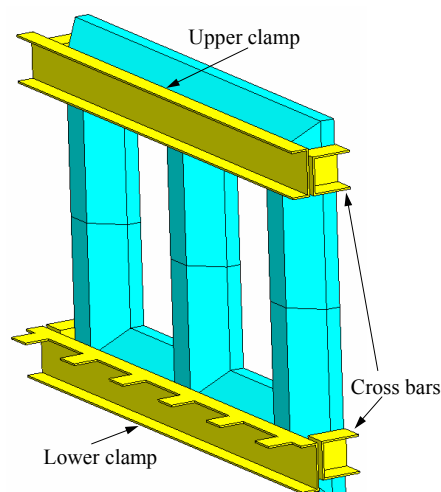

Fig. 1: One half of transformer core with lower clamps, upper clamps and crossbars.

## III. SURFACE IMPEDANCE

The 3D model of power transformer based on finite element method, with applied AC solver, is used to analyze the leakage magnetic fields. The transformer dimensions are measured in meters and for detailed electromagnetic analysis a very large number of finite elements would be needed. This would be especially true if the electrically conductive parts, such as tank walls and yoke clamps are treated as volumes. It is necessary to realize that they should be described by very dense finite element mesh, due to small depth of magnetic field penetration (2) into conducting parts. Dimensions of each finite element in tank walls and clamps should be in the size class below millimeter. So the number of finite elements would increase above software computational possibilities. For this purpose, so-called surface impedance is introduced. This will significantly

Lenart Kralj is with ETRA 33 Power Transformers, Slandrova 10, Ljubljana, Slovenia (e-mail: lenart.kralj@siol.net).  
Damijan Miljavec is with the University of Ljubljana, Faculty of electrical engineering, Trzaska 25, 1000 Ljubljana, Slovenia (e-mail: Damijan.Miljavec@fe.uni-lj.si).

reduce the number of finite elements and allow the calculation of losses in the tank walls and other transformer's construction parts.

### A. Linear Surface Impedance

The description of conductive construction parts with the magnetically linear surface impedance is only approximate, since we are dealing with conductive parts that have mostly non-linear magnetic  $B(H)$  characteristic. Surface impedance connects the electric and magnetic field on the surface of the conductor (1). The impedance is introduced on the base of the boundary conditions between the ideal conductor (construction) and an insulator (transformer oil) [1]:

$$Z_{sl} = \frac{E_s}{H_s} = \frac{1+j}{\delta \sigma} \quad (1)$$

In upper equation the variable:

$$\delta = \sqrt{\frac{2}{\omega \sigma \mu}} \quad (2)$$

represents the depth of penetration, meanwhile  $\sigma$  is material specific electrical conductivity,  $\omega$  is electrical frequency and  $\mu$  is material permeability.

In the analysis we will assume that the most losses occur in the range of depth of penetration, which is a fact in a magnetic material [2]. We also assume that the magnetic field is constant in whole depth of penetration. This means, the magnetic field is not decreasing exponentially with the thickness of the conductor as it is in a real conductor. In this way, we can calculate the losses  $P$  with surface integral of real part of surface impedance  $Z_{sl}$  (1) and known values of magnetic field  $H_s$  just above the surface  $A_s$  of introduced linear surface impedance  $Z_{sl}$ . And, in the form of equation:

$$P_{sl} = \frac{1}{2} \iint_{A_s} \text{Re}(Z_{sl}) \cdot |H_s|^2 dA \quad (3)$$

### B. Nonlinear surface impedance

Construction parts (crossbars, clamps, tank walls ...) are mainly from the conductive and magnetically nonlinear material, so these we must take this into account when calculating the losses. Nonlinear surface impedance is introduced with a help of the assumption that  $B(H)$  curve is presented by the two extreme forms. First one is the presentation with the step function and a second one is a linear function as it is shown in Fig. 2 [2, 3].

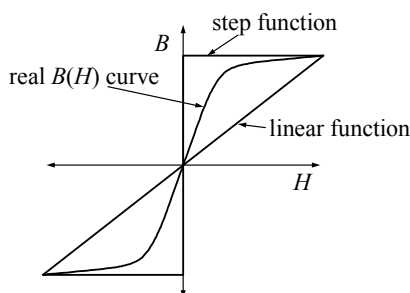

Fig. 2: The presentation of real  $B(H)$  curve with the step function and with the linear function.

Such a simplification allows the analytical derivation of equations for the surface impedance [2] in the case of a rectangular (step)  $B(H)$  characteristic (4). The equation is derived in a similar way as it was done for the linear surface impedance (1). The non-linear (4) and linear surface impedance (5) are linked together with weighted function (6) in the final surface impedance  $Z_{sn}$  (7). The weighted function (6) determines which part (linear or nonlinear) dominates in final surface impedance  $Z_{sn}$  (7).

$$Z_{snl} = \sqrt{\frac{3}{4}} \cdot 1,69 \frac{1}{\sigma \delta_{Ag}} (1+0,5j), \quad (4)$$

$$Z_{sl} = \frac{1}{\sigma \delta_{Ag}} (1+j), \quad (5)$$

$$f(H_s) = \frac{1}{1 + \frac{H_s}{H_k}}, \quad (6)$$

$$Z_{sn} = f(H_s) Z_{sl} + (1 - f(H_s)) Z_{snl}, \quad (7)$$

$$\delta_{Ag} = \sqrt{\frac{2}{\omega \sigma} \frac{H_s}{B(H_s)}}. \quad (8)$$

In (4) appears quotient  $\sqrt{3/4}$  which is adopted purely empirical [2]. In the weighted function (6) there is a  $H_k$  which presents the knee value (in nonlinear  $B(H)$  curve) of magnetic field, in our case the value is  $H_k = 600$  A/m. The depth of penetration  $\delta_{Ag}$  (8) is now in function of  $B(H)$  curve and defines the absolute penetration of magnetic field into conductor. The values of  $H_s$  in  $B_s$  (calculated by FEM AC solver) are on the surface of conductive construction parts (for example, tank wall) with specific conductivity  $\sigma = 5 \cdot 10^6$  S/m.

The losses are now calculated in a similar way as it was done for linear case (3). In this case, the linear surface impedance  $Z_{sl}$  is substituted by non-linear  $Z_{sn}$  (4). In form of equation this becomes:

$$P_{sn} = \frac{1}{2} \iint_{A_s} \text{Re}(Z_{sn}) \cdot |H_s|^2 dA \quad (9)$$

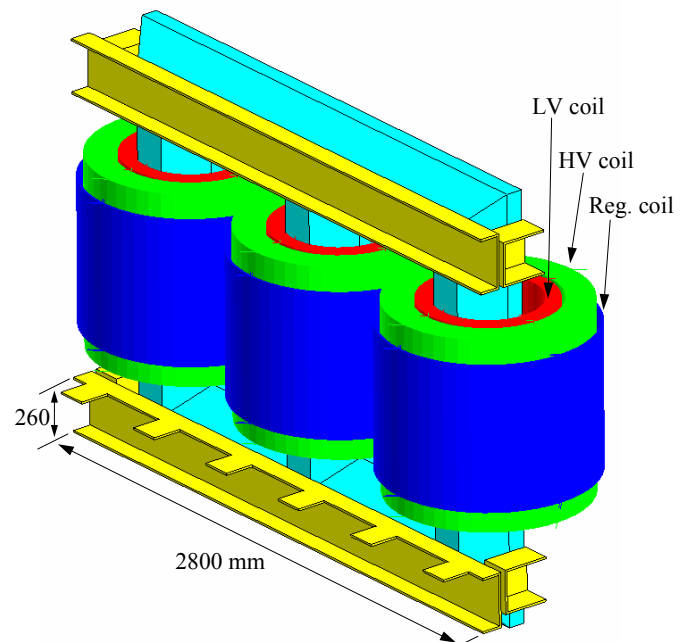

Fig. 3: Power transformer yoke and windings.

#### IV. 3-D MODEL OF POWER TRANSFORMER

The 3D finite element model is made based on dimensions of real power transformer from the company Etra 33. All the numerical calculations of magnetic fields and eddy current losses were done by commercial software package Cedrat Flux 3D [4].

The electric connections between the coils and the tank wall insulator as well as limb clamps were not taken into account. The limb clamps (between the core and the windings) are made from stainless steel and due to this; they are not presenting a significant source of stray losses and are not included in the analyze. The windings are not described by finite elements, but with current loops (conductors) of prescribed dimensions. The current density is uniform over the cross section of the winding conductors. Regarding the use of non-meshed windings the reduced magnetic scalar potential can be engaged in solving the magnetic fields. The distribution of magnetic fields in the transformer tank (oil) is calculated from Biot-Savart's law.

The symmetry of whole transformer with the tank could allow modeling only half of the system and with this to reduce the computational time. But, on the other hand, the real transformer is not symmetrically built-up. The side of transformer with high voltage terminals is longer in comparison with the low voltage side. The distances depends on power transformers voltage levels. To estimate the error produced by taking into account just the symmetry of power transformer the comparative analyze (symmetric model vs. real model) was done, too. The parametrically defined geometric model (Fig. 3) allows us to analyze a large number of power transformers. The ampere-turns balanced states corresponding to the nominal working condition are in phasor form. The balances of the nominal ampere-turns are assumed for the coils wound on the same leg. The excitations in form of ampere-turns are described by effective value with phase angle.

The main disadvantage of used method for eddy current losses calculation is that all electromagnetic quantities harmonically fluctuate by first harmonic. This is not the case when we deal with non-linear characteristic of iron. Because of this magnetic non-linearity the magnetic field in the material has non-sinusoidal form. Nevertheless, the losses are calculated relatively accurate by the introduction of equivalent  $B(H)$  characteristics based on equality of the energy [4].

#### V. RESULTS

Eddy current losses  $P_{v,calc}$  in the tank walls and other construction parts were calculated for many different fabricated power transformers (Table I).

The stray losses  $P_v$  of analyzed transformers were determined by using indirect measuring procedure based on the short circuit method. By this method we measure the overall short circuit losses  $P_k$  and Joule losses, due to resistance of the transformer windings,  $P_{cu}$ . The additional eddy current losses  $P_{dod\_cu}$ , which arise in the windings due to leakage magnetic fields, were calculated based on [5]. The measured stray losses are in form of equation:

$$P_v = P_k - P_{cu} - P_{dod\_cu} \quad (10)$$

The measurement results for different types of power transformers are presented in Table 1.

TABLE I  
MEASURED STRAY LOSSES IN DIFFERENT POWER TRANSFORMERS

No.	Model	$P_k$ [kW]	$P_{cu}$ [kW]	$P_{dod\_Cu}$ [kW]	$P_v$ [kW]
1.	RT 10000-22,5/11,5	44,2	38,3	4,3	1,6
2.	RT 25000-33/6,3	120	90,7	11,5	17,8
3.	NT 40000-110/6,3	171	133,1	20,9	17

To estimate the error produced by taking into account just the symmetry of power transformer the comparative analyze is presented in Table II. There are shown results for both symmetric and a-symmetric model of power transformer. The symmetry plain is lying parallel to the plane of the transformer height (Fig. 3). As we can see the error of such simplification is very small. On the other hand, the computational time is significantly decreased.

TABLE II  
DIFFERENCE BETWEEN CALCULATED LOSSES FOR SYMMETRIC AND A-SYMMETRIC MODEL FOR TWO TYPES OF POWER TRANSFORMER

Model	$P_{sn\_sym}$ [W] symmetric FEM model	$P_{sn\_asym}$ [W] a-symmetric (real) FEM model
RT 25000-33/6,3	14970	14550
NT 40000-110/6,3	14430	14330

The calculated eddy current losses  $P_{sn}$  using (9) for all treated power transformers are presented separately for the tank walls, the lower and the upper clamps and crossbar (Table III). All losses are analyzed at the nominal loads.

TABLE III  
CALCULATED EDDY CURRENT LOSSES REGARDING THEIR ORIGIN AND DISCREPANCY BETWEEN COMPUTED  $P_{sn}$  AND MEASURED STRAY LOSSES  $P_v$ .

No.	Lower clamp [kW]	Upper clamp [kW]	Crossbar [kW]	Tank walls [kW]	$P_{sn}$ [kW]	$P_v$ [kW]
1.	0,16	0,08	0,03	1,08	1,35	1,6
2.	2,45	1,24	1,31	9,97	14,97	17,8
3.	2,26	1,5	1,21	9,46	14,43	17

The comparison between the computed losses  $P_{sn}$  and the experimental results  $P_v$  shows the difference. The disparity in results are mainly due to used approximation of modeled  $B(H)$  curve for surface impedance, not taken into account hysteresis losses, unconsidered electric connections between the coils and the tank wall insulator as well as limb clamps were not taken into account. The quality of the calculated additional eddy current losses  $P_{dod\_cu}$  in the windings can be discussed. On the other side, the measurement uncertainty is also present. The difference between calculated and measured results has both signs; this means that in some models the calculated losses are smaller than measured ones and vice-versa. All exposed dilemmas in stray losses calculation show the complexity of the problem.

The eddy current losses distributions in different parts of power transformer type RT 25000 kVA-33 kV/6,3kV are shown in Fig. 4, Fig. 5 and Fig. 6. The results are calculated using modified eq. (3) for nonlinear case and eq. (4) joined together into eq. (9).

The use of equations for linear (1) and nonlinear (7) surface impedance lead to different results for eddy current losses calculated in tank walls and in construction parts. The results are shown in Table IV.

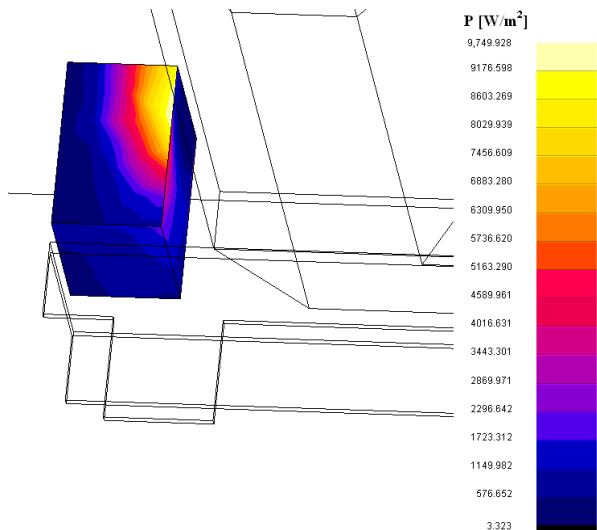

Fig. 4: Eddy current losses distribution in lower crossbar close to phase windings of power transformer type RT 25000 kVA-33 kV/6,3kV.

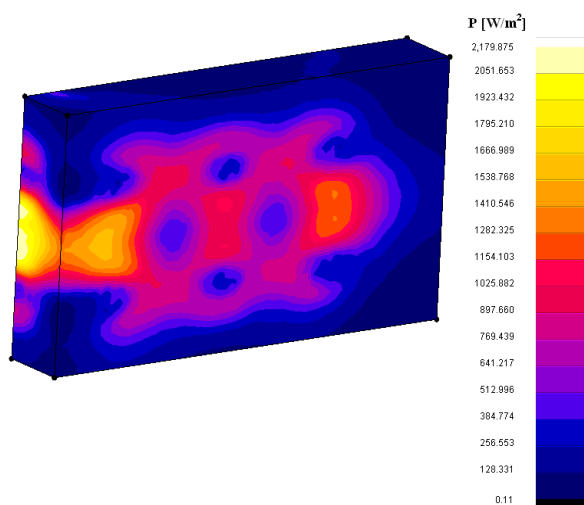

Fig. 5 : Eddy current losses distribution on inner surface of the tank walls of power transformer type RT 25000 kVA-33 kV/6,3kV.

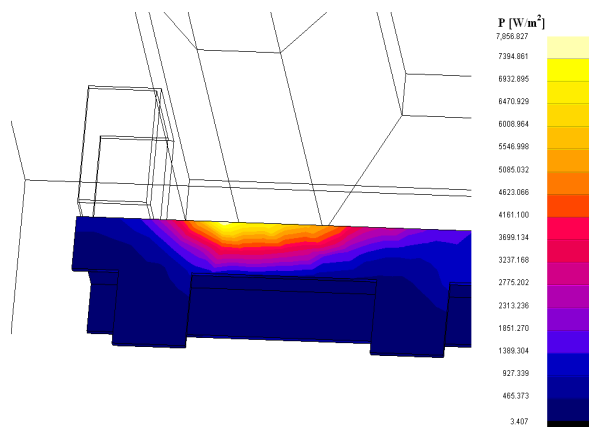

Fig. 6: Eddy current losses distribution in lower clamp close to phase windings of power transformer type RT 25000 kVA-33kV/6,3kV.

Regarding the results gathered together in Table IV, we can see the error which is done by using linear magnetic characteristic of material ( $\mu_r=100$ ) and with specific conductivity  $\sigma=5 \cdot 10^6$  S/m instead presenting the magnetic material with nonlinear properties. The losses  $P_{sl}$  calculated by using linear  $B(H)$  characteristic are twice smaller regarding measured stray losses. The advantage of using linear surface impedance (1) is in faster calculations, up to eight times.

TABLE IV  
COMPARISON BETWEEN MEASURED STRAY LOSSES  $P_v$ , CALCULATED EDDY CURRENT LOSSES  $P_{sn}$  USING NONLINEAR  $B(H)$  CHARACTERISTIC OF MATERIAL AND LOSSES  $P_{sl}$  USING LINEAR  $B(H)$  CHARACTERISTIC

No.	$P_v$ [kW]	$P_{sn}$ (eq. 9) [kW]	$P_{sl}$ (eq. 3) [kW]
1.	1,6	1,35	0,985
2.	17,8	14,97	8,575
3.	17,0	14,43	8,43

## VI. CONCLUSIONS

From the treated cases of different power transformer designs can be deduced that the eddy current losses in tank walls and other construction parts can be quite accurately calculated.

Inaccuracy of calculations can be mainly ascribed to mathematical simplifications and to material's nonlinear magnetic properties description. The results show the difference in eddy current losses using linear and non-linear surface impedance. This comparison was done to draw the attention on inexactness of using linear surface impedance in such calculus.

It should be pointed out that in spite of inaccurate calculations regarding absolute values we have a method to define the best position of clamps and crossbars to achieve minimum losses. The impact of material properties on overall losses in power transformer construction parts can be also studied applying presented method.

## VII. REFERENCES

- [1] J. Mlakar, *Electro-magnetic fluctuation*, University of Ljubljana, Faculty of electrical engineering, 2002
- [2] P.D. Agarwal, "Eddy current losses in solid and laminated iron", *Trans. AIEE*, vol.1.78, pt 11, pp.169-179, 1959.
- [3] C. Guerin, et al., Surface impedance for 3D non-linear Eddy current problems—application to loss computation in transformers, *IEEE Trans. Magn.* 32 (1996) 808–811.
- [4] User's Guide Flux 3d, Cedrat, 2009.
- [5] A. Jurman, "Leakage magnetic field and the transformer", M.Sc Thesis, University of Ljubljana, Faculty of electrical engineering, 2008.
- [6] M.A. Venegas Vega1, R. Escarela Pérez, T. Niewierowicz, "3D Finite Element Estimation of Stray Losses in Three-Phase Transformers," *JOURNAL OF APPLIED COMPUTER SCIENCE*, Vol. 16. No 1 pp. 89-100, 2008.
- [7] M. Rizzo, A. Savini and J. Turowski, "Influence of Flux Collectors on Stray Losses in Transformers," *IEEE Trans. Magn.*, vol. 36, No. 4, JULY 2000.
- [8] Chetan C. Adalja and M.L. Jain, "Analysis of Stray Losses in Power Transformers by 3-D Magnetic Field Simulation" presented at Fifteenth National Power Systems Conference (NPSC), IIT Bombay, December 2008.
- [9] L. Susnjic, Z. Haznadar and Z. Valkovic "3D finite-element determination of stray losses in power transformer," *Electric Power Systems Research* 78, pp. 1814–1818, 2008.

**Lenart Kralj** received the B. Tech. degree in electrical engineering from the University of Ljubljana, Slovenia in 2010. Currently he is a researcher at ETRA 33 company. His research interests include the design, modeling, and analyze of power transformers.

**Damijan Miljavec** received the B. Tech., M. Sc. and the Ph. D. degree in electrical engineering from the University of Ljubljana, Slovenia, in 1993, 1996 and 1999, respectively. Currently, he is a Professor of Electrical Machines at the University of Ljubljana, Faculty of electrical engineering, where he heads the Electrical Machine Laboratory. His research interests include the design, modeling and analyze of electromechanical converters.