

Accepted Manuscript

Modeling, analysis and mitigation of contagion in financial systems

Xian Cheng, Haichuan Zhao

PII: S0264-9993(18)30248-7

DOI: [10.1016/j.econmod.2018.08.007](https://doi.org/10.1016/j.econmod.2018.08.007)

Reference: ECMODE 4700

To appear in: *Economic Modelling*

Received Date: 18 February 2018

Revised Date: 1 July 2018

Accepted Date: 9 August 2018

Please cite this article as: Cheng, X., Zhao, H., Modeling, analysis and mitigation of contagion in financial systems, *Economic Modelling* (2018), doi: 10.1016/j.econmod.2018.08.007.

This is a PDF file of an unedited manuscript that has been accepted for publication. As a service to our customers we are providing this early version of the manuscript. The manuscript will undergo copyediting, typesetting, and review of the resulting proof before it is published in its final form. Please note that during the production process errors may be discovered which could affect the content, and all legal disclaimers that apply to the journal pertain.

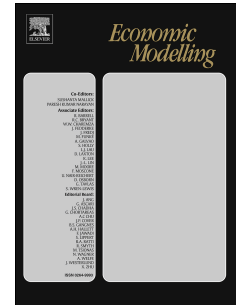

Modeling, Analysis and Mitigation of Contagion in Financial Systems

Xian Cheng ^a, Haichuan Zhao ^{b, *},

^a Department of Electronic Commerce and Information Management, School of Economics & Management, Southwest Jiaotong University, Chengdu, China;

^b Department of Marketing, School of Management, Shandong University, No.27 Shanda South Road, Jinan, China.

* Correspondence concerning this article should be addressed to Haichuan Zhao, Department of Marketing, School of Management, Shandong University, No.27 Shanda South Road, Jinan, China. Tel.: +86 15725137866, E-mail Address: zhhc@sdu.edu.cn

Abstract

Recent financial turmoil (e.g., the 2008-2009 global financial crisis) has resulted in financial contagion-induced instability becoming one of the major concerns in the fields of economics and finance. In this paper, we extend the network analysis of financial contagion from three perspectives. First, given that cross-holding of claims and obligations among financial institutions can be viewed as input-output linkages, we model the financial system and the contagion mechanism by introducing the classic Leontief input-output framework. Second, based on this modeling process, we propose a simple contagion algorithm to study how financial system heterogeneity influences its stability. Third, to mitigate financial contagion, we propose several concrete intervention policies based on two widely used prudential approaches—forced mergers and capital injections. The performance of these intervention policies is then evaluated by comprehensive numerical experiments. Our study has significant implications for financial regulation and supervision.

JEL Classification: C63, C67, D85, G21.

Keywords: Financial Contagion; Financial Stability; Intervention Policy; Financial Regulation; Network Analysis.

Modeling, Analysis and Mitigation of Contagion in Financial Systems

Abstract

Recent financial turmoil (e.g., the 2008-2009 global financial crisis) has resulted in financial contagion-induced instability becoming one of the major concerns in the fields of economics and finance. In this paper, we extend the network analysis of financial contagion from three perspectives. First, given that cross-holding of claims and obligations among financial institutions can be viewed as input-output linkages, we model the financial system and the contagion mechanism by introducing the classic Leontief input-output framework. Second, based on this modeling process, we propose a simple contagion algorithm to study how financial system heterogeneity influences its stability. Third, to mitigate financial contagion, we propose several concrete intervention policies based on two widely used prudential approaches—forced mergers and capital injections. The performance of these intervention policies is then evaluated by comprehensive numerical experiments. Our study has significant implications for financial regulation and supervision.

JEL Classification: C63, C67, D85, G21.

Keywords: Financial Contagion; Financial Stability; Intervention Policy; Financial Regulation; Network Analysis.

1. Introduction

The increasing frequency and scope of financial crises has not only made financial stability one of the major concerns of academic scientists and policymakers but also revealed the necessity of changing from a micro-prudential approach to a macro-prudential approach when considering the regulation and supervision of financial risk management (Borio, 2011). One crucial characteristic of such crises is the systemic risk of financial contagion—i.e., the potential for the failure (such as distress, insolvency or default) of one financial institution to propagate through interconnectedness, causing other institutions to fail or even the whole financial system to collapse in an unforeseen domino effect (Brownlees and Engle, 2016). Such interconnectedness is indeed a feature of the modern financial system owing to financial innovation and liberalization; financial institutions are directly interconnected¹ due to the bilateral exposures (cross-holding of claims and obligations) created in the interbank market, where institutions with surplus liquidity can lend to those with liquidity shortages. These bilateral exposures are often reflected in the interconnected balance sheets as assets and liabilities.

As the financial system can be labeled a network of interconnectedness (cross-holding of claims and obligations), network theory has been used intensively to model it and to analyze financial contagion in general, where the network reflects the interconnectedness of the financial system. Particularly, a large body of network literature has emerged detailing both theoretical studies (including simulation studies) (Acemoglu et al., 2015; Amini and Minca, 2016; Elliott et al., 2014) and empirical applications (Greenwood et al., 2015; Levy Carciente

¹ Financial institutions can also be indirectly interconnected with one another, such as by overlapping portfolio exposures; see Section 2.1.

et al., 2014) aimed at analyzing a wide range of issues regarding financial contagion and financial stability. However, there are several shortcomings in the existing literature. First, a particular focus of those works is how the probability and extent of financial contagion are influenced by bilateral exposures and interconnectedness (Caccioli et al., 2015; Elliott et al., 2014), which are often measured using the average of degree and the average of exposures, respectively. However, these are not considered to be sufficient measures. For example, a regular network and a random network may have the same average of degree, but the interconnectedness of the two networks may not necessarily be the same. Second, much of the literature merely uses financial institutions' book values on balance sheets (Gai et al., 2011; Nier et al., 2007), even though these cannot reflect institutions' true value due to the ever-present inflation between book value and market value. Third, although financial contagion has become a major concern of financial regulators and supervisors, attempts to understand how to mitigate it are still in the early stage (Galati and Moessner, 2013), and there is a need to design and implement concrete intervention policies when the financial system is under distress.

The above considerations motivated our study. In particular, as the cross-holding of claims and obligations can be viewed as input-output linkages, we aim to extend the network approach to studying financial contagion using the classic Leontief input-output framework. Using the input-output framework, we start by analyzing financial contagion in an interconnected financial system based on the disturbance of market value. We then propose a simple contagion algorithm to study the effects of the diversification of bilateral exposures (reflected by the mean and variance of exposure) and interconnectedness (reflected by the

mean and variance of degree) on financial contagion using numerical simulation. Finally, we focus on the design and implementation of intervention policies based on two prudential approaches—forced mergers and capital injections—for mitigating financial contagion to enhance the stability of the financial system. The main standpoints of these policies follow the Basel III agreement, concentrating on systemically important financial institutions, e.g., the “too-big-to-fail” (TBTF) or the “too-connected-to-fail” (TCTF). We adopt several network-related indicators to measure the interconnectedness of the financial system. In line with these measures, we implement the intervention instrument of forced mergers or capital injections to the systemically important financial institutions. The performance of these intervention policies is then evaluated by comprehensive numerical experiments.

The contribution of this research can be summarized as follows.

First, our work supplements the network approach to financial contagion by introducing the classic Leontief input–output analysis. A financial network consists of the relationships formed by the cross-holding of claims and obligations. Our motivation for using an input–output analysis stems from its wide use in studying risk management in cross-holdings across business groups (Crowther and Haines, 2005; Hallegatte, 2008; Henriot et al., 2012).

Second, our work has significant implications for financial regulation and supervision, particularly in business intelligence-related financial risk management (Hu et al., 2012). As highlighted by the recent financial crisis, it is not enough to implement purely micro-prudential policies (Basel I and Basel II) for financial regulation and supervision, as such policies merely concentrate on the state of financial institutions in isolation (Galati and Moessner, 2013). Instead, there is a growing consensus that policymakers should adopt a

macro-prudential approach to regulation and supervision. The macro-prudential approach (Basel III) views the financial system as a whole by taking the effect of systemic risk into account (Galati and Moessner, 2013; Hasman, 2013). By considering the framework of micro-prudential and macro-prudential regulations together, we propose several concrete intervention policies for bailing out systemically important financial institutions—by forced mergers or capital injections where the systemic important financial institutions are either the institutions with higher bilateral exposures or the institutions with higher interconnectedness.

The remainder of this paper is organized as follows. Section 2 examines the related work; Section 3 presents the modeling process; Section 4 studies the effect of diversification of bilateral exposures and interconnectedness on the stability of the financial system; Section 5 proposes and evaluates intervention policies; and, finally, Section 6 presents conclusions.

2. Related Work

2.1 Financial Contagion and Financial Stability

Our work is related to multiple strands of the extant literature. In its modeling of financial networks, this paper is closely related to the literature on financial contagion and financial stability. The seminal work of Allen and Gale (2000) pioneers this strand of theoretical study by showing how the network structure affects risk sharing. Following this outstanding work, a large number of studies on financial contagion have used network or graph models. Financial contagion in a financial system mainly occurs via three mechanisms. The first is correlation risk resulting from overlapping portfolios (Caccioli et al., 2015;

Dehmamy et al., 2014). There is portfolio overlap between two institutions if they both invest in the same asset, and they will be affected if the market price of the asset decreases. As a result, the institutions are indirectly interconnected by the portfolio overlap. The second mechanism is illiquidity risk due to rumor or information asymmetry (Brunnermeier, 2008; Calvo and Mendoza, 2000; Gai et al., 2011). Rumor or information asymmetry causes depositor panics characterized by unwarranted withdrawals. These withdrawals place undue pressure on a financial institution's liquidity. Finally, the third mechanism is counterparty risk arising from direct bilateral exposures (Farboodi, 2014; Georg, 2013; Pegoraro, 2012). Our work focuses on the third mechanism, in which the bilateral exposures are formed by the cross-holding of claims and obligations.

Many studies consider interconnectedness and bilateral exposures as major influences on financial contagion and the stability of the financial system (Caccioli et al., 2012; Elliott et al., 2014; Georg, 2013). These works identify the “knife-edge” or “robust-yet-fragile” properties of financial networks, referring to the trade-off between risk sharing and risk propagating that comes with the increase of interconnectedness.

2.2 Prudential Regulations and Interventions

Our work is also related to the literature on financial regulation and surveillance. The recent financial crisis brought the issue of systemic risk due to financial contagion to the attention of governments and regulatory agencies, leading to calls for better management of financial stability (Patro et al., 2013). Moreover, many academics have also highlighted the importance of taking a macro-prudential approach to ensure financial stability (Borio, 2011). In contrast to micro-prudential regulation, which mainly concentrates on the stability of

individual financial institutions from a local perspective, macro-prudential regulation focuses on the stability of the whole system by adopting effective intervention policies from a system-wide perspective. This shift has imposed complexities on the analysis of systemic events (Flood et al., 2013) and also accentuated the need to better understand not only individual financial components but also their interconnectedness and systemic risk contributions (Mezei and Sarlin, 2018).

Under the paradigm of prudential regulation, much of the extant literature focuses on identifying systemically important financial institutions (SIFIs). Traditional works focused on institutions considered “too big to fail,” identifying them as SIFIs. After the crisis of 2008-2009, however, it became necessary to focus not only on “big” institutions but also well-connected ones, which may function as hubs for failure contagion. These are referred to as “too-interconnected-to-fail” institutions. Some works in the literature model financial interdependency networks to measure those SIFIs that are always well-connected (Martinez-Jaramillo et al., 2014).

Aside from identifying SIFIs, several papers focus on developing concrete intervention policies under the framework of macro-prudential regulation. However, there is no general agreement on an adequate policy response (Bluhm and Krahen, 2014). Two widely used intervention policies are forced mergers (Greenwood et al., 2015; Hryckiewicz, 2014) and capital injections (Berger et al., 2016; Mehran and Thakor, 2010). These intervention policies can be further divided into two groups: systemic policies concentrating on all financial institutions and simple instruments aimed at rescuing single institutions (Farhi and Tirole, 2012).

2.3 Early Warning

This paper is also closely linked to the literature on early warning for financial crises. Reliable and credible early warning indicators or systems would help policymakers prevent financial crises or at least limit their potential adverse effects on the economy (Lang and Schmidt, 2016). There are many theoretical and empirical studies focusing on building early warning indicators. In the theoretical literature, Kaminsky et al. (1998) presented a non-parametric method—a static signal extraction approach enabling identification of certain variables. In contrast, Saleh et al. (2012) developed a dynamic model for determining indicators' thresholds, focusing more on the volatility of indicators. More recently, Billio et al. (2016) proposed an entropy-based early warning indicator for systemic risk.

The empirical literature has come up with various econometric models to develop an early warning framework. Fuertes and Kalotychou (2006) applied pooled logit models to predict debt crises in emerging economies. Similarly, Jedidi (2013) used a fixed-effects logit model to forecast sovereign debt crises. More recently, Caggiano et al., (2016) compared the performance of binomial and multinomial logit models in the context of building early warning systems for systemic banking crises.

2.4 Input-output Analysis

This study is partly related to the literature on input-output analysis. Since its original development by Leontief to study the US economy (Leontief, 1986), input-output analysis has been one of the most widely applied methods in economics (Chen et al., 2016). The fundamental purpose of the input–output framework is to analyze the interdependence of individual parts of an economic system. Examples of its use include inter-industry analysis

(Wiedmann et al., 2006), the analysis of cross-holdings in business (Bonacich, 1987), risk analysis of large-scale interdependent systems (Crowther and Haines, 2005) and the analysis of energy efficiency (Garrett-Peltier, 2017).

Several papers also use input-output analysis with a focus on financial contagion. Acemoglu et al. (2015) use the Cobb-Douglas production technologies to study the interaction between the shape of firm-level shock distributions and the structure of the input-output network. Similarly, Aldasoro and Angeloni, (2014) use input-output analysis to measure the systemic importance of financial institutions. It is worth noting that the paper of Elliott et al. (2014) is related to our work in that it focuses on the effect of integration (the average of exposures) and diversification (the average of degree) on financial contagion. However, our work contains several important differences. First, we focus on the cross-holding of claims and obligations based on information from balance sheets. Second, in addition to average exposures and degree, we investigate the effect of variance. Finally, using the input-output framework, we propose and perform several intervention policies for mitigating the probability and extent of financial contagion.

3. Modeling and Contagion Mechanism

3.1 Pre-description

One striking characteristic of the modern financial system is interconnectedness: financial institutions are directly interconnected due to the cross-holding of claims or obligations created in the interbank market, where financial institutions with surplus liquidity can lend to those with liquidity shortages. Interbank markets play a key role in financial

systems, as their main purpose is to allocate liquidity efficiently. At times of crisis, however, they also act as channels for financial contagion. If the value of one financial institution sharply decreases in a short space of time from an idiosyncratic shock, the institution may fail and go into liquidation, when its value is below the failure threshold. This failure may then induce losses on its counterparties in the interconnected balance sheets, which may then result in the counterparties themselves failing, inducing losses on their own counterparties, and so on. This dynamic is what leads to failure contagion (financial contagion) in the financial system.

As the cross-holding of claims and obligations can be viewed as input-output linkages, here we adopt the classic Leontief input–output framework. It is reasonable to consider these cross-holding relationships as input-output linkages. For example, financial institution A holds a certain share of financial institution B’s assets; this share can be viewed as the input of institution B, or equally, the output of institution A. Furthermore, the balance sheets of financial institutions often reveal the cross-holding claims or obligations. We adopt a deliberately oversimplified balance sheet, as shown in Figure 1, to denote the financial institution. The structure of assets and liabilities in the balance sheet reflects the cross-holdings. On the assets side (the output side), “Internal Assets” denotes the amount of total shares of other institutions (the total intermediate output). The remainder of the assets consists of a range of “External Assets,” which are the holdings of other real economies (the total final output), where these external assets can be considered the investment of the institution, such as high-quality government bonds, mortgages, corporate lending and commercial real estate lending. As our main purpose is to study financial contagion in an

interconnected network, we assume each institution to have a single and independent investment project. This assumption indicates that there is no correlation between the external assets for each institution, which enables us to focus on direct bilateral exposures and to ignore the indirect linkages of correlated external assets. On the other side of the balance sheet, liabilities consist of “Deposits” and “Internal Liabilities.” Deposits are the share of input from outside of the system, such as from the household, while internal liabilities are the share of input from other institutions. “Equity” is the capital buffer, which denotes the excess of total assets (output) over total liabilities (input).

Using the input-output framework and network theory, we model a financial system as an interconnected financial network. In the network, each node represents a financial institution and each link represents a directional holding of claims or obligations between two institutions. Thus, both the intrinsic characteristics of individual financial institutions and the structure of the entire financial network—two major influence factors for the magnitude of financial contagion and the stability of the financial system—are clearly reflected in the financial network. In particular, these two influence factors are usually denoted by the diversification of bilateral exposures and interconnectedness, respectively. Indeed, a financial network has a particular bilateral exposures sequence or interconnectedness sequence, and these unique sequences determine the resilience and stability of the financial system in times of distress. For example, greater interconnectedness means that an idiosyncratic shock is more easily dissipated and absorbed (risk sharing) when an institution is highly interconnected. On the flip side, an institution with high interconnectedness will also have a high probability of being hit by a failure through one of its counterparties.

3.2 Financial System Modeling

Figure 1 is an illustration of a typical financial system, where each institution is represented by a deliberately oversimplified balance sheet. Here we consider a financial system in which n financial institutions form an interconnected network by their claims or obligations on one another. The cross-holdings can be represented by an exposure matrix $\mathbf{W} \in \mathbf{R}^{n \times n}$, where the element w_{ij} is the share of institution j that is held by institution i ($i, j \in N, N = \{1, 2, \dots, n\}$). Here we should highlight that $w_{ii} = \mathbf{0}$ for each i in the financial network. We denote the corresponding adjacency matrix of \mathbf{W} as \mathbf{G} , where $g_{ij} = \mathbf{1}$ when $w_{ij} > \mathbf{0}$, otherwise $\mathbf{0}$. Aside from the cross-holding shares, the remainder $\hat{w}_{ii} = \mathbf{1} - \sum_{j=1}^n w_{ji}$ of bank i is the share owned by its owners-operators. In fact, this is the part owned by outside shareholders that are external to the system of cross-holdings. We adopt a diagonal matrix $\hat{\mathbf{W}}$ to depict these shares, where the off-diagonal entries of the matrix are defined to be $\mathbf{0}$. Now we turn to the structure of assets and liabilities for individual financial institutions. We use $A_i, L_i, A_i^E, A_i^I, L_i^I, D_i$ and E_i to denote institution i 's total assets, total liabilities, external assets, internal assets, internal liabilities, deposits and equity, respectively.

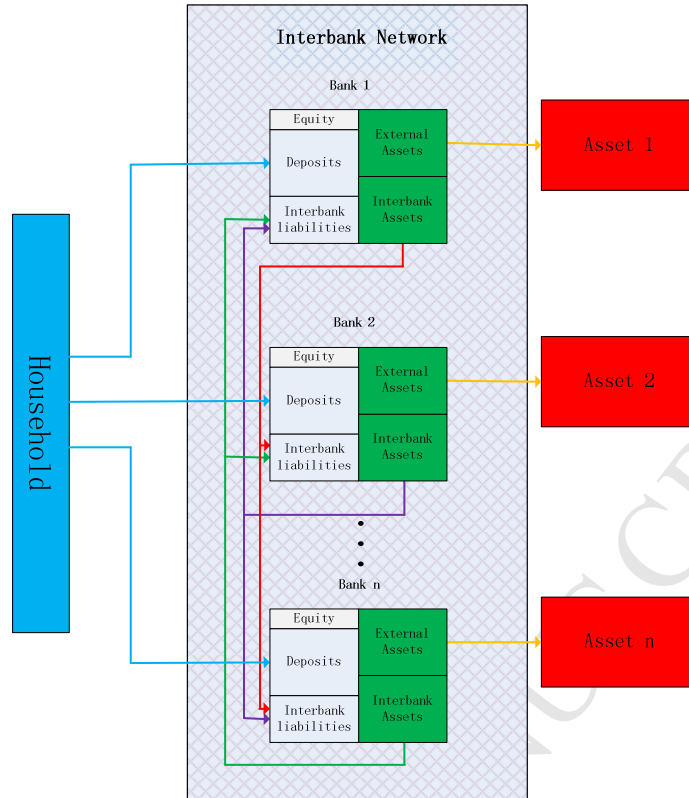

Figure 1. An illustration of a financial system where each institution is represented by a deliberately oversimplified balance sheet and the structure of assets and liabilities reflects the cross-holdings.

Definition–financial system. A financial system $(\mathbf{W}, \{\mathbf{A}_i^E\}, \{\mathbf{E}_i\})$, is defined by

- 1) an exposure matrix $\mathbf{W} \in \mathbf{R}^{n \times n}$;
- 2) a sequence of $\{\mathbf{A}_i^E\}_{1 \leq i \leq n}$;
- 3) a sequence of $\{\mathbf{E}_i\}_{1 \leq i \leq n}$.

Based on this information, we can obtain the sequence of bilateral exposures $\{\alpha_i\}_{1 \leq i \leq n}$ and the sequence of interconnectedness $\{d_i\}_{1 \leq i \leq n}$.

$$\alpha_i = \sum_{j=1}^n w_{ji} = \mathbf{A}_i^l / \mathbf{A}_i \quad (1);$$

$$d_i = \mathbf{a}_i^{in} + \mathbf{a}_i^{out} = \sum_{j=1}^n g_{ij} + \sum_{j=1}^n g_{ji} \quad (2)$$

Without loss of generality, here we merely consider the output side (assets) of the financial system. According to the balance sheet, the book value of institution i can be

obtained as follows.

$$V_i^{book} = A_i^I + A_i^E = \sum_{j=1}^n w_{ij} V_j^{book} + A_i^E \quad (3)$$

Equation (3) can be rewritten in matrix notation as $V^{book} = WV^{book} + A^E$ and solved to yield (4), where $V^{book} = (V_1^{book}, V_2^{book}, \dots, V_n^{book})$, $A^E = (A_1^E, A_2^E, \dots, A_n^E)$ are $n \times 1$ column vectors, and $(I - W)^{-1}$ is the well-known Leontief inverse.

$$V^{book} = (I - W)^{-1} A^E \quad (4)$$

We refer to the market value of a financial institution as the non-inflated value, which is the share of the book value that is held by its owner-operators (Elliott et al., 2014). Thus, taking the market value of institution i to be equal to $\hat{w}_{ii} V_i^{book}$, we can obtain equation (5).

$$V^{market} = \hat{W} V^{book} = \hat{W} (I - W)^{-1} A^E \quad (5)$$

We refer to $\hat{W} (I - W)^{-1} = R$ as the Relevance matrix, where R is column-stochastic.

3.3 Contagion Mechanism

For a financial institution, the value shared by the owners-operators is $\hat{w}_{ii} V_i^{book}$. If this value is sufficiently low (e.g., a random exogenous shock to the value of the institution's external assets), the owners-operators may choose to cease operations and liquidate the institution. If an institution ceases operations and goes into liquidation, its value sharply decreases due to the liquidation costs, such as the cost of assessing value, losses involving idle assets and holding costs for sales assets. Thus, we assume that there is a threshold value \underline{V}_i^{market} such that if the value V_i^{market} of institution i falls below this threshold level, then i is said to fail and incurs liquidation costs C_i^{liq} . This leads to a new version of (5) market value:

$$V^{market} = \hat{W} V^{book} = R(A^E - C^{liq}) \quad (6)$$

The entry R_{ij} of the Relevance matrix describes the proportion of institution j 's liquidation costs that institution i bears when j fails. As the liquidation costs of failed institutions are distributed across the interconnected network through the cross-holding relationships, small idiosyncratic shocks to a single institution may have a significant effect on the system as a whole by triggering an avalanche of failures. Specifically, when institution j fails, thereby incurring liquidation costs of C_j^{liq} , i 's value will decrease by $R_{ij}C_j^{liq}$. If $\Delta V_i = V_i^{market} - \underline{V}_i^{market}$ is negative, then institution i will fail. The liquidation of institution i will lead to decreased market value for its creditors, and this may cause the failure of creditors, and so forth. This illustrates the mechanism of financial contagion through an interconnected network, which is the foundation of this study. Here we present a contagion algorithm to trace the propagation of failure. This type of algorithm can also be found in other works on financial contagion (Eisenberg and Noe, 2001; Elliott et al., 2014; Elsinger et al., 2006).

The pseudo algorithm is presented below.

Input: exposure matrix W , a sequence of $\{A_i^E\}_{1 \leq i \leq n}$, liquidation costs vector C^{liq} .

Output: total set of failed institutions $Fail_T$.

- (1) Initialize. $Fail_t$ is the set of failed institutions at time t ; let \tilde{C}_t be a vector with element $\tilde{C}_i = C_i^{liq}$ if $i \in Fail_{t-1}$ and 0 otherwise ($t \geq 1$); randomly select one financial institution to fail ($\#Fail_0 = 1$);
- (2) Do $\Delta V_t = R(A^E - \tilde{C}_{t-1}) - \underline{V}^{market}$;
- (3) Count the total number of negative values in ΔV_t , denoting as N_t , update $Fail_t$;
- (4) If $N_t > N_{t-1}$, then set $t = t + 1$, and return to step (2)

else return \mathbf{Fail}_t and terminate the algorithm.

If the algorithm is terminated at time T , the set of \mathbf{Fail}_T corresponds to the total set of failed institutions. According to this algorithm, we can find the failed institution at any given time by comparing the number of new entries in \mathbf{Fail}_t to those in \mathbf{Fail}_{t-1} , where these new entries are institutions whose failures are induced by the aggregate of prior losses.

4. Diversification of Bilateral Exposures and Interconnectedness

4.1 Diversification of Bilateral Exposures

For simplicity, we consider a financial system to be a network where n ($n=100$) institutions are randomly interconnected, and each institution has an independent and equal external asset (i.e., there are no correlations among those assets). The random network can be represented as the adjacency matrix \mathbf{G} , where $g_{ij} = 1$ denotes that institution i has cross-holdings in institution j , and the diagonal entries $g_{ii} = 0$. We assume that the sequence of bilateral exposures obeys a normal distribution $\alpha \sim N(\mu, \sigma)$, where $\mu \in (0, 1)$ denotes the average exposure. Thus, α_i indicates the total interbank exposures of institution i , which are spread evenly among the institutions in the i 'th column of the adjacency matrix \mathbf{G} . To illustrate the effect of diversification of interbank exposures, we assume that there is a common failure threshold $\underline{v}^{market} = \theta V^{market}$ for a parameter $\theta \in (0, 1)$. We set n as 100, and construct 60 random networks by different probabilities P for forming a link between each couple of nodes. We then perform the contagion algorithm on each random network, repeating the simulation 1000 times to average out stochastic effects and to obtain robust results.

To evaluate the magnitude of financial contagion, we introduce two measure indicators:

The *probability of contagion*, defined as the probability of the occurrence of a contagion event; and the *extent of contagion*, defined as the average number of institutions that fail as a result of the initial failure if a contagion event occurs. The probability of contagion reflects the susceptibility of a financial system to financial contagion, while the extent of contagion reflects the stability of the financial system.

$$\text{The Probability of Contagion} = \frac{\text{Number of contagion events observed}}{\text{Number of total experiments}} \quad (9)$$

$$\text{The Extent of Contagion} = \frac{\text{Number of total failed institutions induced by contagion}}{\text{Number of contagion events observed}} \quad (10)$$

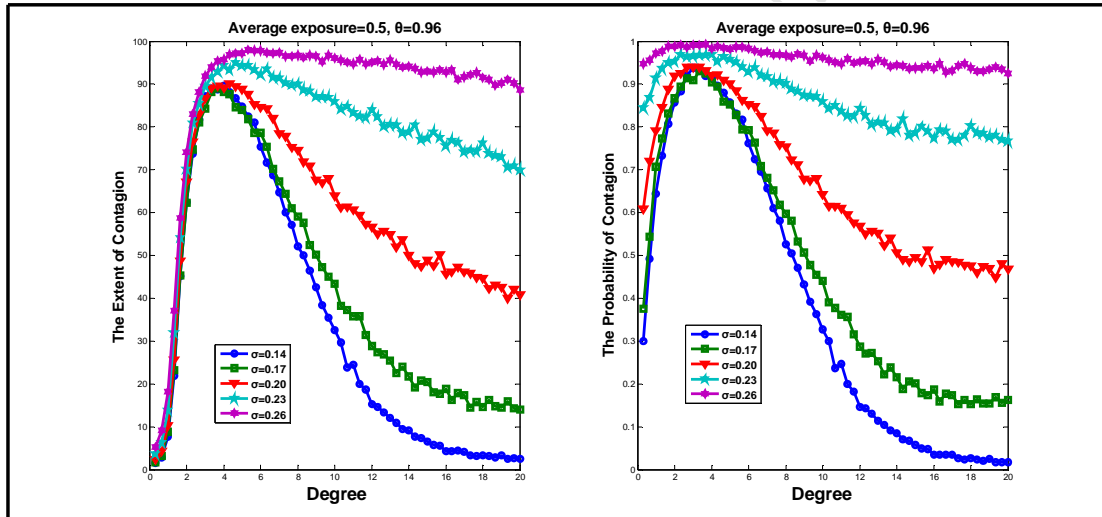

Figure 2. The “knife-edge” property of a financial system (σ denotes the variance of bilateral exposures). The extent of contagion and the probability of contagion as a function of interconnectedness (reflected by degree) display inverted U-shaped curves.

Figure 2 identifies the “knife-edge” or “robust-yet-fragile” property of financial networks that is also identified in other works, such as Caccioli et al., (2014). In particular, Figure 2 shows how the extent and probability of contagion change as interconnectedness increases (reflected by degree). For both the extent and probability of contagion, the property of non-monotonicity is represented as inverted U-shaped curves.² Focusing on the blue curve,

² For other scenarios, please refer to the Supplemental Information.

as the degree increases in the range of 0 to 5, both the contagion extent and contagion probability sharply increase as the interconnectedness takes the role of “risk spreading.” As we further increase the degree (in the range of 5 to 20), both the contagion extent and contagion probability dramatically decrease as connectivity takes the role of “risk sharing.”

In addition, Figure 2 shows the effect of varying σ , which denotes the variance of bilateral exposures. Generally speaking, both the extent and probability of contagion increase as σ increases. More specifically, as the degree varies in the range of 0 to 5, the extent of financial contagion only slightly changes with the increase of σ , while the probability of contagion dramatically changes. One reasonable interpretation is that the higher the value of σ , the greater the diversification of bilateral exposures. The diversification then makes the financial system more sensitive to financial contagion, but as the network is incompletely interconnected (the degree is lower), a typical institution is interconnected through cross-holdings with only a small fraction of the other institutions. Thus, financial contagion is limited to a small component (reflected by the small value of the contagion extent). However, when the degree is in the range of 5 to 20, both the contagion probability and contagion extent increase as we continue to increase the value of σ . Figure 3 further illustrates how the changes in contagion probability and contagion extent differ. As the variance of exposures varies in the range of 0 to 0.3, the contagion extent slightly increases, but the change in contagion probability is more significant, especially when the degree is small.

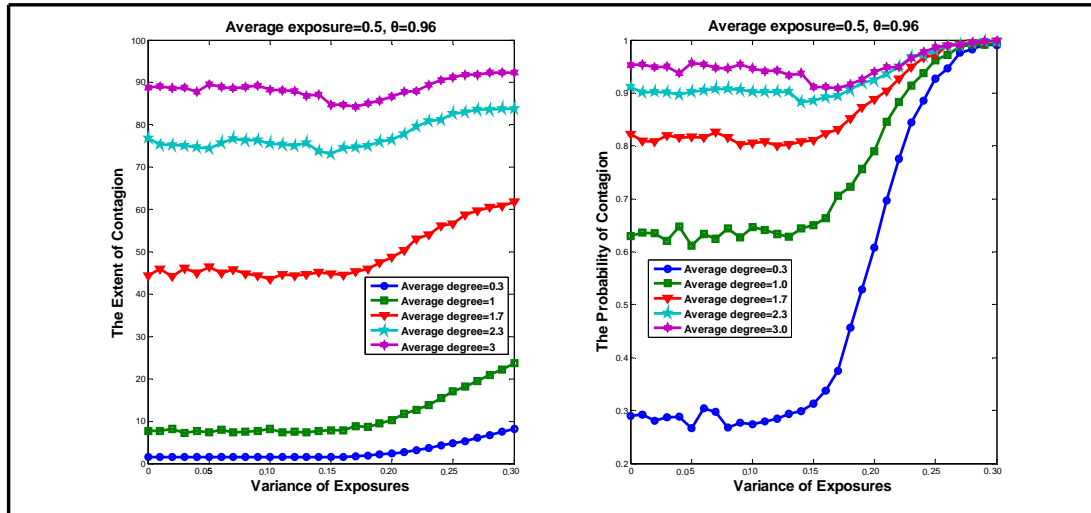

Figure 3. How the diversification of bilateral exposures affects the extent and probability of contagion. The variance of exposures corresponds to the diversification of bilateral exposures for the financial system where the average exposure is 0.5 and θ equals 0.96.

4.2 Diversification of Interconnectedness

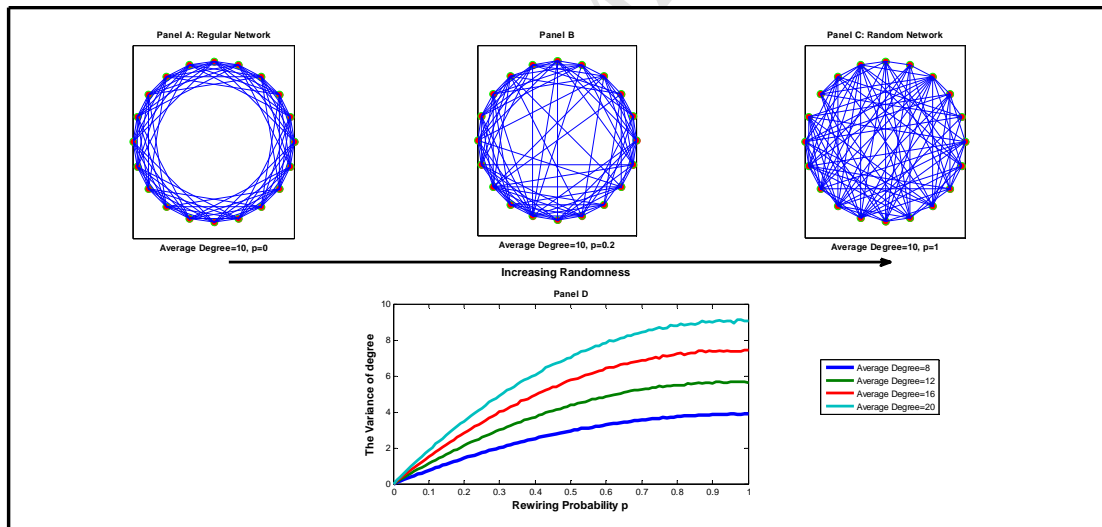

Figure 4. An illustration of network topology for different rewiring probabilities based on the WS model (Panel A-Panel C); Panel D shows the changing of the variance of degree with the varying of the rewiring probability.

In this subsection, we investigate the effect of the diversification of interconnectedness on financial contagion. The challenge is to construct a set of networks in which the degree sequences have the same mean but different variance; to this end, we adopt the Watts and Strogatz (WS) model (Watts and Strogatz, 1998) to satisfy this feature. Figure 4 illustrates the WS model; for $p = 0$, the network is a regular network (panel A), while for $p = 1$ it is a

random network (panel C). A higher rewiring probability increases the randomness of the network, so by varying this tunable parameter, we can model numerous different kinds of networks that have the same average degree but different variance.

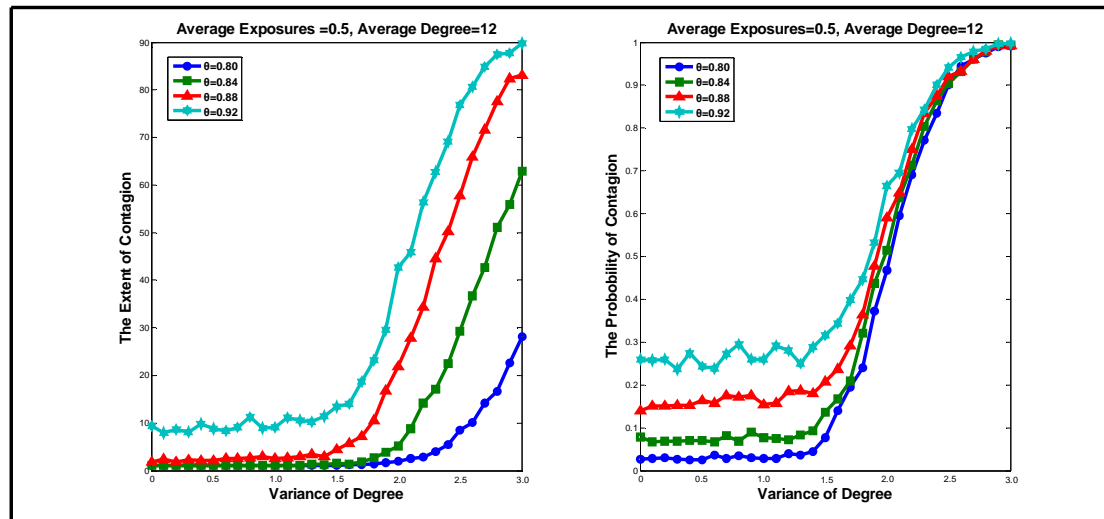

Figure 5. How the diversification of interconnectedness affects the extent and probability of contagion. The diversification of interconnectedness is measured by variance of degree for the financial system, where average exposure is 0.5 and average degree is 12.

Based on the WS model, we construct a set of networks and perform the contagion algorithm on these financial systems. Figure 5 shows the effect of the diversification of interconnectedness (reflected by the variance of degree); here we set the average exposure to 0.5 and the average degree to 12. We find that both the extent of contagion and the probability of contagion slightly increase as the variance of degree varies in the range of 0 to 1.5. However, when the variance of degree continues to increase (in the range of 1.5 to 3), both the contagion extent and probability significantly increase. Figure 5 also illustrates the effect of varying θ . Given that both the contagion extent and probability increase as θ grows, it is intuitive that a higher value of θ indicates a higher failures threshold, so that the financial system more easily induces financial contagion.

In this section, we investigate the effect of diversification of bilateral exposures and

interconnectedness on financial contagion. We find that the increase of diversification has a negative influence on financial stability. This result coincides with the conclusion of the seminal paper of (Allen and Gale, 2000), in which the authors point out that a complete network can absorb shocks, but an incomplete network can spread negative spillovers throughout the entire system. Indeed, there is almost no heterogeneity in a complete network. However, given that there is significant heterogeneity among financial institutions in an incomplete network, financial contagion easily occurs in such a network under distress or in a time of crisis. Heterogeneity in a financial system creates a higher risk exposure in case of distress, making systemic failure through financial contagion more likely to occur. In fact, many empirical investigations have shown that the existing financial structure was socially suboptimal due to the high systemic risk that emerged from the heterogeneity of financial systems (Laeven and Valencia, 2013; Roukny et al., 2014). For example, Laeven and Valencia (2013) found that the world's top financial centers—which have always had a high level of heterogeneity—were the ones that most often suffered financial crises; since 1945, the financial systems of France, the United States and the United Kingdom have collapsed 15, 13 and 12 times, respectively. Our study supports and sheds further light on such empirical findings.

5. Intervention Policy

5.1 Proposed Policies

There are two instruments that are used for the reconstruction and recapitalization of financial systems: forced mergers and capital injections (Greenwood et al., 2015; Sorokin,

2010). In practice, when implementing these two instruments to bail out financial institutions, one problem regulators face is choosing the target institutions to merge or inject capital into. The terms TBTF and TCTF remind regulators to concentrate on SIFIs that display either higher bilateral exposures or higher interconnectedness. It is therefore reasonable to consider financial institutions with high bilateral exposures or high interconnectedness to be SIFIs, and the bailouts instrument should focus on these institutions. Thus, we propose six concrete intervention policies, which are described in Table 1. In detail, we rank the systemic importance of financial institutions based on six indicators: bilateral exposure, in-degree, out-degree, closeness, clustering coefficient and eigenvector.³ The bilateral exposure, in-degree and out-degree indicators are in the framework of micro-prudential regulation, as their focus is limited to - individual financial institution's exposure or interconnectedness from a local perspective. However, the closeness, clustering coefficient and eigenvector indicators measure the institution's interconnectedness from a global perspective and thus follows the framework of macro-prudential regulation. In the framework of micro-prudential regulation, there are six concrete intervention policies (three for forced mergers and three for capital injection); analogously, there are also six policies in the macro-prudential regulation framework. We now use the model and contagion mechanism to evaluate the performance of these concrete intervention policies by comprehensive numerical simulation. To be clear, as we assume the exogenous adjustment strategy for financial institutions, we do not consider whether the institutions behave optimally. Rather, these intervention policies should be interpreted as potential ex-post policies that could be used in the midst of a crisis.

³ In network theory, In-degree and out-degree measure the local connectivity, closeness, clustering coefficient and eigenvector measure the global connectivity. For more information please refer to Supplement Information.

Table 1. Intervention Policies for forced mergers and capital injections

Intervention Instrument	Forced Mergers	Capital Injections	
In micro-prudential regulation framework	<i>Ranking by Bilateral Exposure</i>	L-FM Policy 1: merging the <i>top K</i> with the <i>last K</i> institutions by bilateral exposure	L-CI Policy 1: uniform injecting capital to the <i>top K</i> institutions by bilateral exposure
	<i>Ranking by Out-degree</i>	L-FM Policy 2: merging the <i>top K</i> with the <i>last K</i> institutions by out-degree	L-CI Policy 2: uniform injecting capital to the <i>top K</i> institutions by out-degree
	<i>Ranking by In-degree</i>	L-FM Policy 3: merging the <i>top K</i> with the <i>last K</i> institutions by in-degree	L-CI Policy 3: uniform injecting capital to the <i>top K</i> institutions by in-degree
In macro-prudential regulation framework	<i>Ranking by Closeness</i>	G-FM Policy 1: merging the <i>top K</i> with the <i>last K</i> institutions by closeness	G-CI Policy 1: uniform injecting capital to the <i>top K</i> institutions by closeness
	<i>Ranking by Clustering Coefficient</i>	G-FM Policy 2: merging the <i>top K</i> with the <i>last K</i> institutions by clustering coefficient	G-CI Policy 2: uniform injecting capital to the <i>top K</i> institutions by clustering coefficient
	<i>Ranking by Eigenvector</i>	G-FM Policy 3: merging the <i>top K</i> with the <i>last K</i> institutions by eigenvector	G-CI Policy 3: uniform injecting capital to the <i>top K</i> institutions by eigenvector

This table shows six concrete intervention policies. The bilateral exposure, in-degree and out-degree indicators are in the framework of micro-prudential regulation, and the closeness, clustering coefficient and eigenvector indicators follow the framework of macro-prudential regulation.

5.2 Performance of Intervention Policies of Forced Mergers

In this subsection, we mainly focus on the performance of the intervention instrument of forced mergers under different policies. The local intervention policies (**L-FM Policy 1**, **L-FM Policy 2** and **L-FM Policy 3**) follow the framework of micro-prudential regulation, and the global intervention policies (**G-FM Policy 1**, **G-FM Policy 2** and **G-FM Policy 3**) are based on the framework of macro-prudential regulation. Following the numerical simulation described in Section 4, we also set the total number of financial institutions in the system at 100 ($n=100$), and these are randomly connected with one another by connection probability P . As the value of P changes in the range (0, 0.2], the average degree of the

system varies from 0 to 20. In addition, we set the average exposures of the system in four classes (0.2, 0.4, 0.6 and 0.8) and fix θ as 0.96 ($\underline{V}^{market} = 0.96 * V^{market}$).

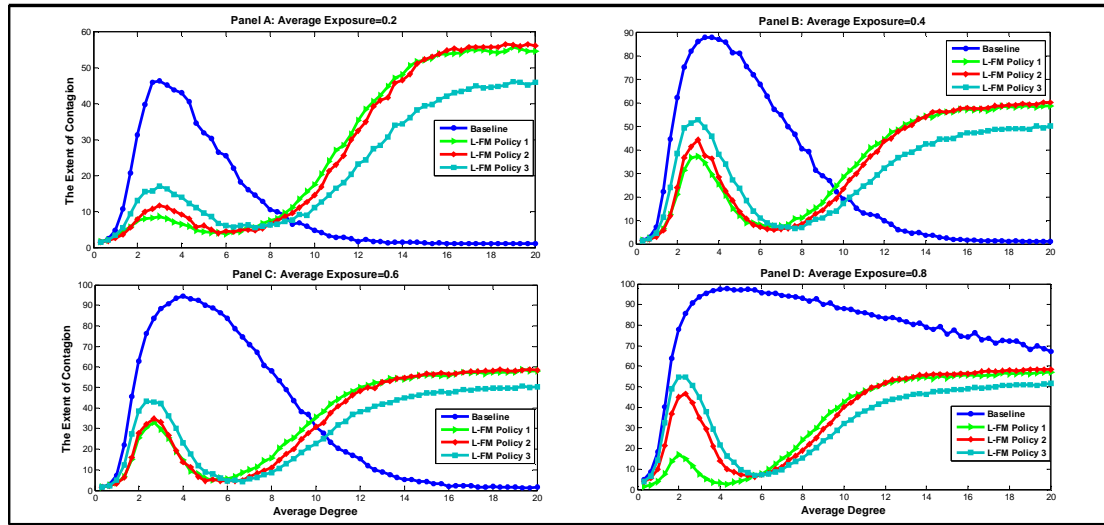

Figure 6. How the local intervention policies for forced mergers (**L-FM Policy 1**, **L-FM Policy 2** and **L-FM Policy 3**) affect the extent of contagion in financial systems with different average exposures. The average exposures for Panel A-D are 0.2, 0.4, 0.6, 0.8, respectively.

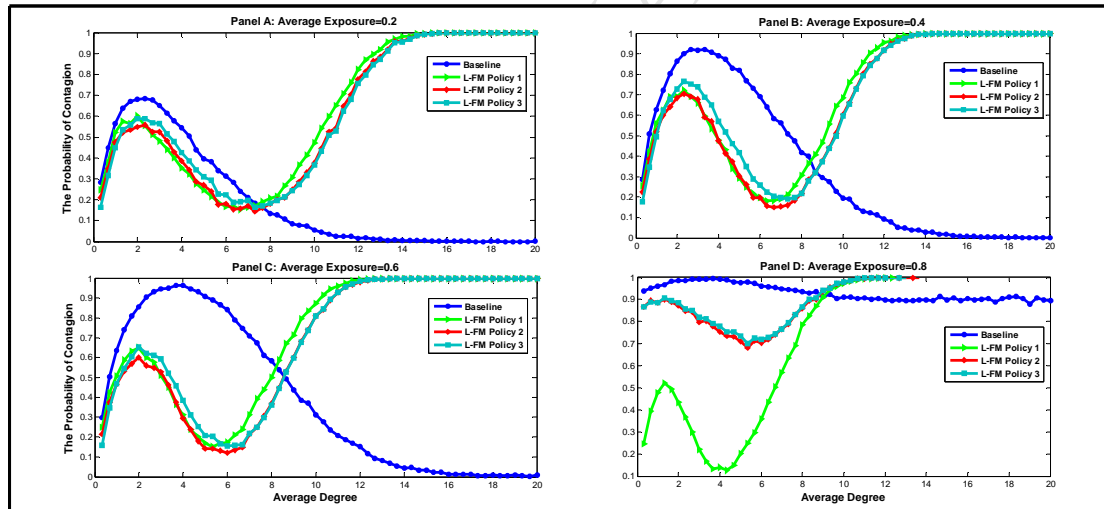

Figure 7. How the local intervention policies for forced mergers (**L-FM Policy 1**, **L-FM Policy 2** and **L-FM Policy 3**) affect the probability of contagion in financial systems with different average exposures. The average exposures for Panel A-D are 0.2, 0.4, 0.6, 0.8, respectively.

Figure 6 and Figure 7 show the results of contagion extent and contagion probability for the local intervention policies, respectively. Here we take the original case in which no intervention policy is implemented as the baseline and set K as 10. Based on these two Figures, we find several interesting results. First, all three intervention policies are effective to

some extent. In particular, as the average degree grows to a certain extent, both the extent of contagion and the probability of contagion are represented by an inverted U-shaped curve for all three policies, and these are significantly smaller than the baseline curves in both width and height. Taking L-FM Policy 2 as an example, when the average degree varies in the interval of 0 to 6, there is always an inverted U-shaped curve for both the extent and the probability of contagion. However, as we continue to increase the average degree, these three policies are not effective at mitigating contagion, as both the contagion extent and probability are significantly higher than the baseline. Second, L-FM Policy 1 is more optimal than the other two policies when they are effective, as seen under the inverted U-shaped curve. When the average degree varies in the range 0 to 6, both the extent and probability of contagion for L-FM Policy 1 are smaller than for L-FM Policies 2 and 3. Thus, in the framework of micro-prudential regulation, we find that the best forced merger policy is based on a financial institution's bilateral exposure (when the interconnectedness of the financial system is relatively small).

Figure 8 and Figure 9 reveal the results of contagion extent and contagion probability for the global intervention policies for forced mergers, respectively. First, we can see that the three global forced merger policies are effective when the interconnectedness of the financial system is small (e.g., the average degree is smaller than 10 in Panel B of Figure 8), but the contagion probability of G-FM Policy 1 and G-FM Policy 2 exceeds the baseline when the average degree is very small (e.g., in Figure 9, the average degree is smaller than 2 in Panel A, B and C). Second, taking into account both contagion extent and contagion probability, we find that G-FM Policy 1 is more optimal than the other two global policies in the

macro-prudential regulation framework.

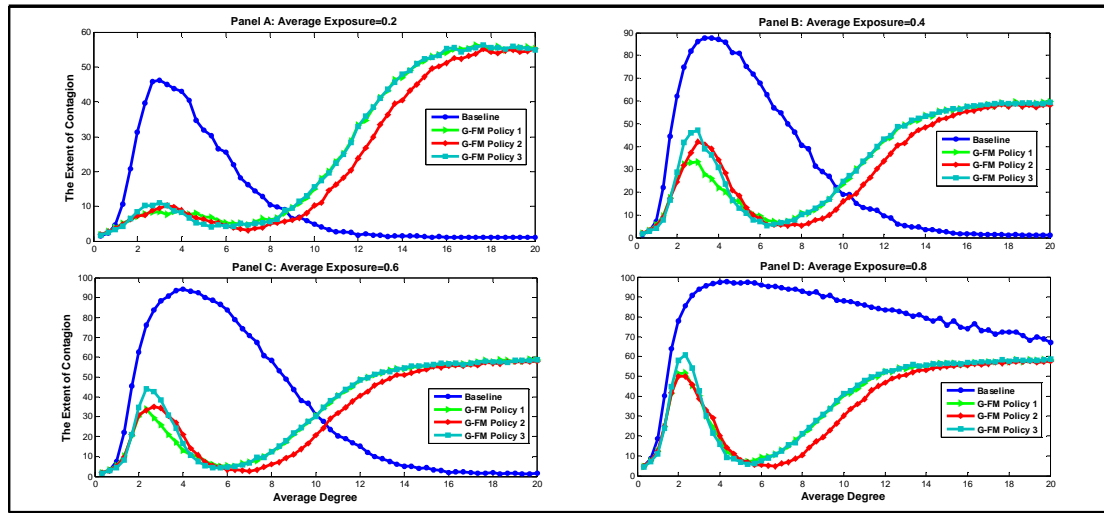

Figure 8. How the global intervention policies for forced mergers (G-FM Policy 1, G-FM Policy 2 and G-FM Policy 3) affect the extent of contagion in financial systems with different average exposures. The average exposures for Panel A-D are 0.2, 0.4, 0.6, 0.8, respectively.

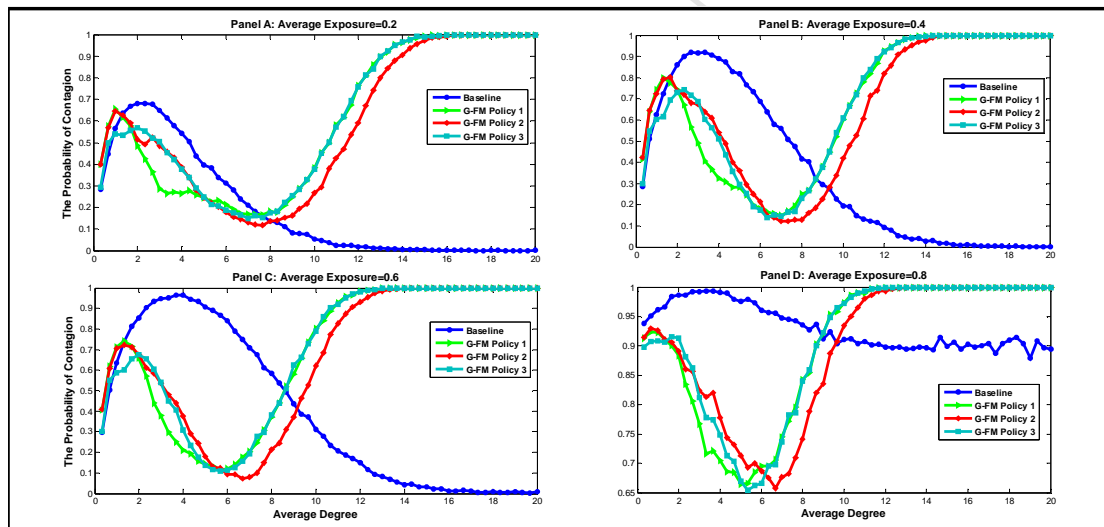

Figure 9. How the global intervention policies for forced mergers (G-FM Policy 1, G-FM Policy 2 and G-FM Policy 3) affects the probability of contagion in financial systems with different average exposures. The average exposures for Panel A-D are 0.2, 0.4, 0.6, 0.8, respectively.

Based on the results of different intervention policies for forced mergers under both the micro-prudential and macro-prudential regulation frameworks, we conclude that forced mergers are an effective intervention instrument to some extent; this accords with existing works Rogers and Veraart (2013), Molyneux et al., (2014), etc. However, as we have illustrated, forced mergers are not always effective, especially in situations where the

interconnectedness of the system is relatively high. There is one probable reason. In a financial system in which financial institutions are highly interconnected, when implementing the forced mergers policy, the diversification of bilateral exposures and the diversification of interconnectedness may change in different directions as forced mergers change the topology of the financial system: the diversification of bilateral exposures in the financial system decreases as expected, but the diversification of interconnectedness increases. Following this logic, when the average degree is high and when we merge the *top K* institutions with the *last K* institutions, the diversification of interconnectedness significantly increases for the new financial system, and this increased diversification has a negative influence on financial stability. Furthermore, we illustrated that L-FM Policy 1 is a better policy for mitigating financial contagion than the other two local intervention policies in the framework of micro-prudential regulation, whereas G-FM Policy 1 is more effective than the other two global intervention policies in the framework of macro-prudential regulation.

5.3 Performance of Intervention Policies of Capital Injections

In this subsection, we concentrate on the performance of capital injections in both micro-prudential and macro-prudential regulation frameworks. We set the value of K as 10, indicating that we implement the intervention policy by injecting capital into the top 10 financial institutions. This setting is reasonable, as in reality regulators always have a certain amount of cash available to bail out institutions in the system, and it is impossible for regulators to inject capital into all institutions. For a target institution i , we set the amount of injected capital to be 10% of its total assets, so the bilateral exposure $\alpha_i = A_i^I / (A_i + 0.1A_i)$

will decrease. Unlike the forced mergers, the capital injections will not change the topology of the financial system, as there is no merger of institutions.

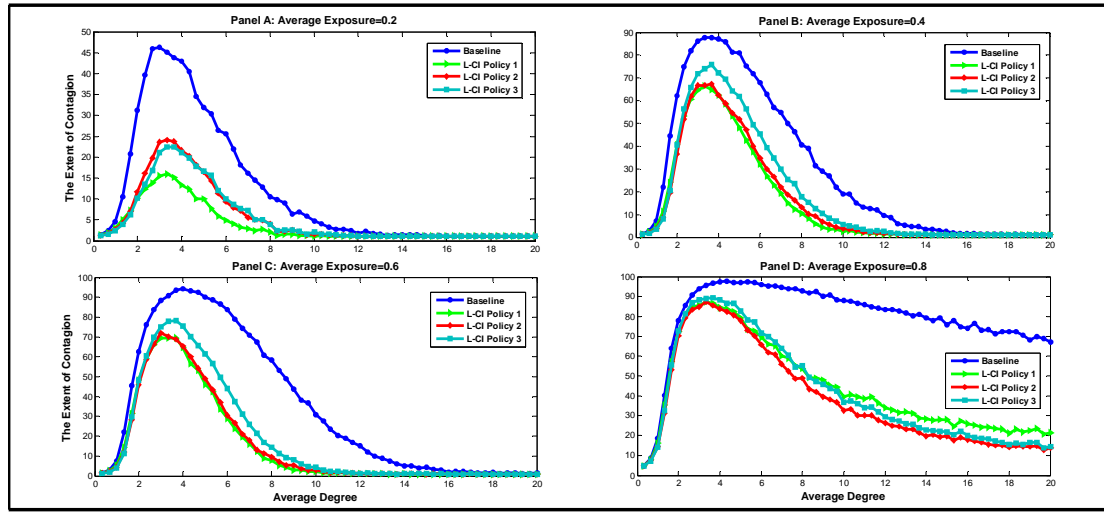

Figure 10. How local intervention policies for capital injection (L- CI Policy 1, L- CI Policy 2 and L- CI Policy 3) affect the extent of contagion in financial systems with different average exposures. The average exposures for Panel A-D are 0.2, 0.4, 0.6, 0.8, respectively.

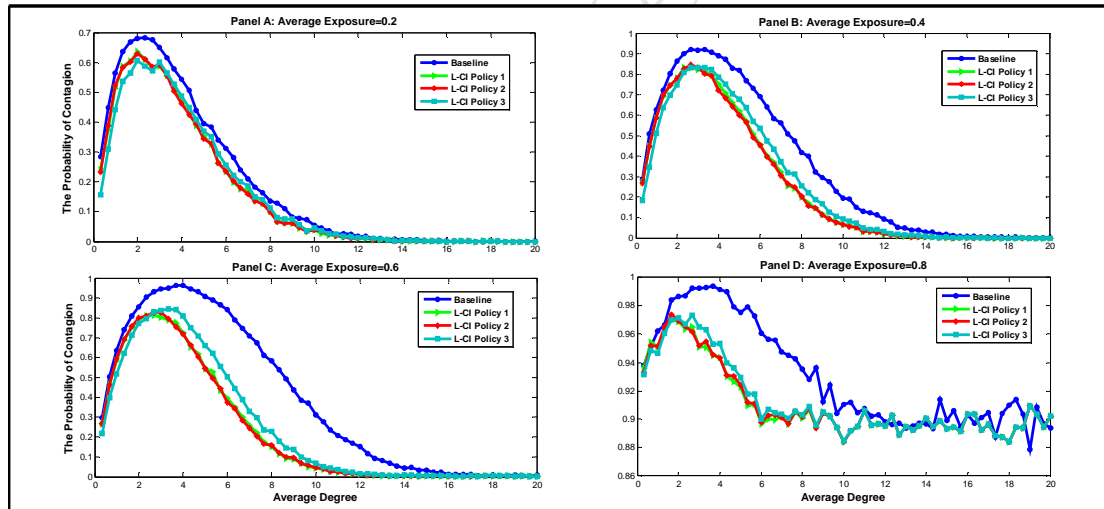

Figure 11. How local intervention policies for capital injection (L- CI Policy 1, L- CI Policy 2 and L- CI Policy 3) affect the probability of contagion in financial systems with different average exposures. The average exposures for Panel A-D are 0.2, 0.4, 0.6, 0.8, respectively.

Figure 10 and Figure 11 show the results of contagion extent and contagion probability for the three local intervention policies for capital injections, respectively. Here we can see that the curves of both contagion extent and contagion probability for these three policies are within the corresponding baseline curve, indicating that these three policies are always

effective for mitigating the extent and probability of financial contagion. In particular, the width and height of the inverted U-shaped curves for these three policies are smaller than the baseline curve. Indeed, these three policies cannot change the interconnectedness of the system, but they can decrease the bilateral exposures for the target institutions. As such, they are effective for mitigating financial contagion. Moreover, the two figures illustrate that L-CI Policy 1 is more optimal than the other two policies. For example, when the average degree varies in the range 2 to 10 and the average exposure equals 0.2 (Panel A of Figure 10), the extent of contagion for L-CI Policy 1 is significantly smaller than that of the other two policies. L-CI Policy 1 injects capital into the top 10 institutions with the highest bilateral exposures, reducing the bilateral exposures of these institutions and significantly decreasing the diversification of the bilateral exposures of the system. However, for L-CI Policies 2 and 3, while it is clear that they can reduce the bilateral exposures of the target institutions, it is not clear that they can significantly reduce the diversification of bilateral exposures, given that an institution with a large out-degree or in-degree is not necessarily an institution with high bilateral exposures. Unlike L-CI Policies 2 and 3, L-CI Policy 1 focuses on reducing the bilateral exposures of institutions with the highest bilateral exposures, and thus it significantly reduces the diversification of the financial system. Therefore, L-CI Policy 1 is more effective than the other two policies most of the time.

We turn to evaluate the performance of the global intervention policies for capital injection. Figure 12 and Figure 13 show the results of contagion extent and contagion probability for the three global intervention policies, respectively. First, we find that all three global intervention policies are effective at mitigating financial contagion in terms of both

extent and probability, as the width and height of the curves for these three policies are smaller than the baseline. Second, the results reveal that G-CI Policy 3 is better than the other two global intervention policies when the average exposure for the financial system is small. For example, in Panel A of both Figure 12 and Figure 13, the curve of G-CI Policy 3 is smaller than those of G-CI Policies 1 and 2.

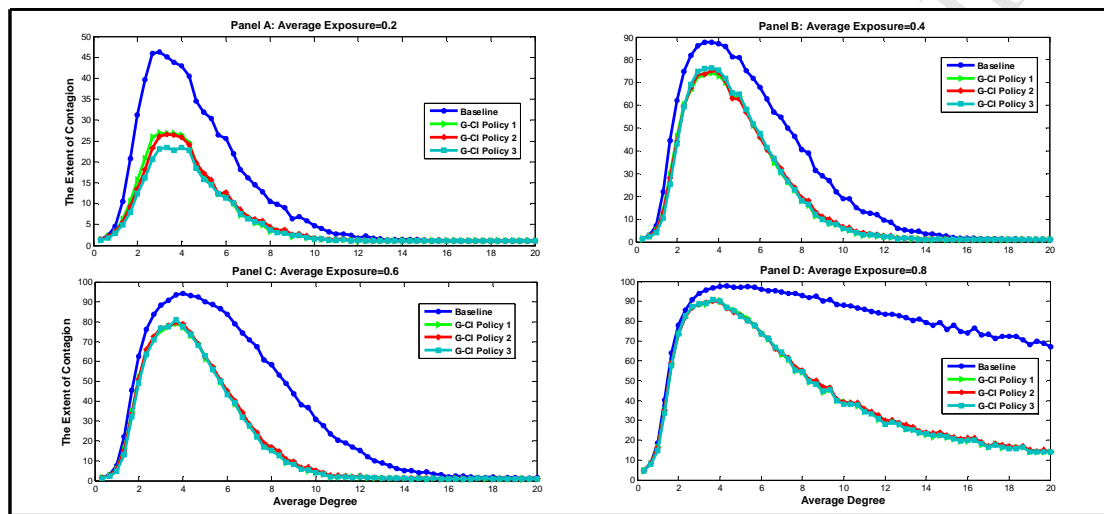

Figure 12. How global intervention policies for capital injection (L-CI Policy 1, L-CI Policy 2 and L-CI Policy 3) affect the extent of contagion in financial systems with different average exposures. The average exposures for Panel A-D are 0.2, 0.4, 0.6, 0.8, respectively.

According to our study on the performance of capital injections under both micro-prudential and macro-prudential regulation frameworks, we conclude that the intervention instrument of capital injection can effectively mitigate financial contagion and reduce the magnitude of systemic risk. Our conclusion is also supported by several prior works such as Bluhm and Krahen (2014), Greenwood et al., (2015) and Berger et al., (2016). Indeed, capital injections help to recapitalize and deleverage financial institutions through balance sheet effects, thus significantly reducing the bilateral exposure in the financial system. In addition, our study also suggests that L-CI Policy 1 and G-CI Policy 3 are more effective than the other policies in their respective frameworks.

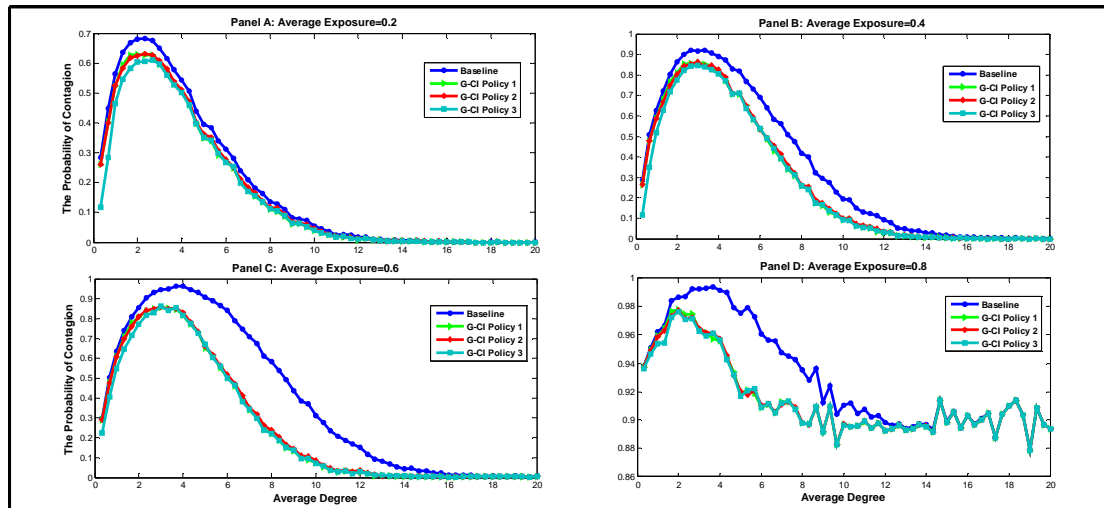

Figure 13. How global intervention policies for capital injection (L-CI Policy 1, L-CI Policy 2 and L-CI Policy 3) affect the probability of contagion in financial systems with different average exposures. The average exposures for Panel A-D are 0.2, 0.4, 0.6, 0.8, respectively.

6. Conclusion and Discussion

In this paper, we focus on extending the network analysis of financial contagion from three perspectives. First, given that the relationships formed by the cross-holding of claims and obligations can be viewed as input-output linkages, we model the financial system and the contagion mechanism by introducing the classic Leontief input-output framework. Based on this modeling process, we propose a simple contagion algorithm to evaluate it further. Second, based on this contagion algorithm, we study how financial system heterogeneity influences its stability. Heterogeneity is measured by the diversification of bilateral exposures and interconnectedness. Based on the results of numerical simulation, we conclude that an increase in the diversification of bilateral exposures and interconnectedness—reflected by the variance of exposure and variance of degree—has a negative influence on financial stability. High variance of exposures and degree intensify financial contagion by increasing both the extent and probability of contagion. Third, to mitigate financial contagion, we propose several concrete intervention policies based on two widely used intervention policies—forced

mergers and capital injection. We implement the intervention policies on systemically important financial institutions, which are determined by high bilateral exposures or high interconnectedness. The performances of these intervention policies are evaluated by comprehensive numerical experiments. Different policies perform differently in mitigating financial contagion. We illustrate that capital injections is an effective instrument for mitigating financial contagion, reducing bilateral exposure in the financial system by recapitalizing and deleveraging financial institutions. However, forced mergers is not always effective. Although forced mergers help to recapitalize financial institutions, they also lead to restructuring of the whole financial system, and this restructuring mechanism may influence systemic risk.

Our work can provide policy suggestions for the surveillance and regulation of a given financial system. From a regulatory perspective, financial supervision should be thought of as a systemic task, focusing not only on the role of nodes to unravel the structure of the system under surveillance—that is, particular financial institutions or banks—but also on the interdependent relationships among these nodes, e.g., a financial early warning system (Koyuncugil and Ozgulbas, 2012). In addition, the research framework can be embedded into business intelligence or decision support technologies for modeling and analyzing financial risk management scenarios, such as stress testing (Hu et al., 2012). Our work can easily be used to perform stress testing and to check the performance of intervention policies.

However, this research has some shortcomings. As mentioned above, there are three mechanisms for financial contagion, but we only study the counterparty risk arising from direct bilateral exposures (the third mechanism). Furthermore, we only focus on the internal

network, although there are other networks in financial systems, e.g., the Bank-Assets network (Caccioli et al., 2015; Lux, 2014). Our research may be furthered through future study of these issues.

References

- Acemoglu D, Ozdaglar A, Tahbaz-Salehi A, 2015. Systemic Risk and Stability in Financial Networks. *Am. Econ. Rev.*105. 564-608
- Aldasoro I, Angeloni I, 2014. Input–output-based measures of systemic importance. *Quant. Financ.*15. 589-606
- Allen F, Gale D, 2000. Financial contagion. *J. Polit. Econ.* 108. 1-33
- Amini H, Minca A, 2016. Inhomogeneous financial networks and contagious links. *Oper. Res.* 64. 1109-1120
- Berger AN, Bouwman CH, Kick TK, Schaeck K, 2016. Bank risk taking and liquidity creation following regulatory interventions and capital support. *Soc.Sci. El. Publ.* 26. 115-141.
- Billio M, Casarin R, Costola M, Pasqualini A, 2016. An entropy-based early warning indicator for systemic risk. *J. Int. Financ. Mark.* 14. 42-59
- Bluhm M, Krahen JP, 2014. Systemic risk in an interconnected banking system with endogenous asset markets. *J. Financ. Stabil.*13. 75-94
- Bonacich P, 1987. Power and centrality: A family of measures. *Am. J. Sociol.* 1170-1182
- Borio C, 2011. Implementing a macroprudential framework: Blending boldness and realism. *Capitalism and Society.*6.
- Brownlees C, Engle RF, 2016. SRISK: A conditional capital shortfall measure of systemic risk. *Rev. Financ. Stud.* 30. 48-79
- Brunnermeier MK 2008. Deciphering the liquidity and credit crunch 2007-08. National Bureau of Economic Research.
- Caccioli F, Catanach TA, Farmer JD, 2012. Heterogeneity, correlations and financial contagion. *Adv. Complex. Syst.* 15.
- Caccioli F, Farmer JD, Foti N, Rockmore D, 2015. Overlapping portfolios, contagion, and financial stability. *J. Econ. Dyn. Control.*51. 50-63
- Caccioli F, Shrestha M, Moore C, Farmer JD, 2014. Stability analysis of financial contagion due to overlapping portfolios. *J. Bank. Finance.*46. 233-245
- Caggiano G, Calice P, Leonida L, Kapetanios G, 2016. Comparing logit-based early warning systems: Does the duration of systemic banking crises matter? *J. Empir. Financ.*37. 104-116
- Calvo GA, Mendoza EG, 2000. Rational contagion and the globalization of securities markets. *J. Int. Econ.*51. 79-113
- Chen Q, Dietzenbacher E, Los B, Yang C, 2016. Modeling the short-run effect of fiscal stimuli on GDP: A new semi-closed input–output model. *Econ. Model.*58. 52-63
- Crowther KG, Haimes YY, 2005. Application of the inoperability input—output model (IIM)

- for systemic risk assessment and management of interdependent infrastructures. *Sys. Eng.*8. 323-341
- Dehmamy N, Buldyrev SV, Havlin S, Stanley HE, Vodenska I, 2014. A Systemic Stress Test Model in Bank-Asset Networks. arXiv preprint arXiv:1410.0104.
- Eisenberg L, Noe TH, 2001. Systemic risk in financial systems. *Manage. Sci.*47. 236-249
- Elliott M, Golub B, Jackson MO, 2014. Financial Networks and Contagion. *Am. Econ. Rev.*10.
- Elsinger H, Lehar A, Summer M, 2006. Risk assessment for banking systems. *Manage. Sci.*52. 1301-1314
- Farboodi M, 2014. Intermediation and voluntary exposure to counterparty risk. Available at SSRN 2535900.
- Farhi E, Tirole J, 2012. Collective moral hazard, maturity mismatch, and systemic bailouts. *Am. Econ. Rev.*102. 60-93
- Flood MD, Mendelowitz AI, Nichols W 2013. Monitoring financial stability in a complex world. . In: Lemieux, V. (Ed.), *Financial Analysis and Risk Management Data Governance, Analytics and Life Cycle Management*.15-45.
- Springer-Verlag, Heidelberg, pp. 15–45. Fuertes A-M, Kalotychou E, 2006. Early warning systems for sovereign debt crises: The role of heterogeneity. *Comput. Stat. Data An.* 51. 1420-1441
- Gai P, Haldane A, Kapadia S, 2011. Complexity, concentration and contagion. *J. Monetary. Econ.*58. 453-470
- Galati G, Moessner R, 2013. Macroprudential policy—a literature review. *J. Econ. Surv.*27. 846-878
- Garrett-Peltier H, 2017. Green versus brown: Comparing the employment impacts of energy efficiency, renewable energy, and fossil fuels using an input-output model. *Econ. Model.*61. 439-447
- Georg C-P, 2013. The effect of the interbank network structure on contagion and common shocks. *J. Bank. Finance* .37. 2216-2228
- Greenwood R, Landier A, Thesmar D, 2015. Vulnerable banks. *J. Financ. Econ.*115. 471-485
- Hallegatte S, 2008. An adaptive regional input - output model and its application to the assessment of the economic cost of katrina. *Risk Anal.*28. 779-799
- Hasman A, 2013. A critical review of contagion risk in banking. *J. Econ. Surv.*27. 978-995
- Henriet F, Hallegatte S, Tabourier L, 2012. Firm-network characteristics and economic robustness to natural disasters. *J. Econ. Dyn. Control* .36. 150-167
- Hryckiewicz A, 2014. What do we know about the impact of government interventions in the banking sector? An assessment of various bailout programs on bank behavior. *J. Bank. Finance.*46. 246-265
- Hu DN, Zhao JL, Hua ZM, Wong MCS, 2012. Network-based modeling and analysis of systemic risk in banking systems. *MIS Quarterly.*36. 1269-1291
- Jedidi O, 2013. Predicting sovereign debt crises: A panel data approach using composite indices. University of Rennes.
- Kaminsky G, Lizondo S, Reinhart CM, 1998. Leading indicators of currency crises. *IMF Staff Papers.*45. 1-48
- Koyuncugil AS, Ozgulbas N, 2012. Financial early warning system model and data mining

- application for risk detection. *Expert. Syst. Appl.* .39. 6238-6253
- Laeven L, Valencia F, 2013. Systemic banking crises database. *IMF Economic Review*.61. 225-270
- Lang M, Schmidt PG, 2016. The early warnings of banking crises: Interaction of broad liquidity and demand deposits. *J. Int. Money. Financ.*61. 1-29
- Leontief WW. *Input-output economics*. Oxford University Press; 1986.
- Levy Carciente S, Kenett DY, Avakian A, Stanley HE, Havlin S, 2014. Dynamical macro-prudential stress testing using network theory. Available at SSRN 2482742.
- Lux T, 2014. Emergence of a core-periphery structure in a simple dynamic model of the interbank market. *J. Econ. Dyn. Control*.
- Martinez-Jaramillo S, Alexandrova-Kabadjova B, Bravo-Benitez B, Solórzano-Margain JP, 2014. An empirical study of the Mexican banking system's network and its implications for systemic risk. *J. Econ. Dyn. Control*.40. 242-265
- Mehran H, Thakor A, 2010. Bank capital and value in the cross-section. *Rev. Financ. Stud.* . 24. 1019-1067.
- Mezei J, Sarlin P, 2018. RiskRank: Measuring interconnected risk. *Econ. Model*.68. 41-50
- Molyneux P, Schaeck K, Zhou TM, 2014. 'Too systemically important to fail' in banking—Evidence from bank mergers and acquisitions. *J. Int. Money. Financ.* .49. 258-282
- Nier E, Yang J, Yorulmazer T, Alentorn A, 2007. Network models and financial stability. *J. Econ. Dyn. Control*.31. 2033-2060
- Patro DK, Qi M, Sun X, 2013. A simple indicator of systemic risk. *J. Financ. Stabil.*9. 105-116
- Pegoraro S, 2012. Financial fragility and contagion in interbank networks. Available at SSRN 2246353.
- Rogers L, Veraart LA, 2013. Failure and rescue in an interbank network. *Manage. Sci.*59. 882-898
- Roukny T, Georg C-P, Battiston S, 2014. A network analysis of the evolution of the German interbank market. Discussion Paper, Deutsche Bundesbank.
- Saleh N, Casu B, Clare A, 2012. Towards a new model for early warning signals for systemic financial fragility and near crises: An application to oecd countries. *Social Science Electronic Publishing*.
- Sorkin AR, 2010. *Too big to fail*. Penguin Books Ltd (UK) .
- Watts DJ, Strogatz SH, 1998. Collective dynamics of 'small-world' networks. *Nature*.393. 440-442
- Wiedmann T, Minx J, Barrett J, Wackernagel M, 2006. Allocating ecological footprints to final consumption categories with input–output analysis. *Ecol. Econ*.56. 28-48

Highlights

1. Financial system and contagion is modelled by Leontief input–output framework.
2. Effect of heterogeneity on financial stability is studied by a contagion algorithm.
3. Several intervention policies are proposed to mitigate financial contagion.
4. Our study has significant implications on financial regulation.