

Accepted Manuscript

Numerical study of water flow rates in power plant cooling systems

Paweł Regucki, Marek Lewkowicz, Renata Krzyżyńska, Hussam Jouhara

PII: S2451-9049(18)30085-4
DOI: <https://doi.org/10.1016/j.tsep.2018.04.015>
Reference: TSEP 170

To appear in: *Thermal Science and Engineering Progress*

Received Date: 9 February 2018
Revised Date: 23 April 2018
Accepted Date: 24 April 2018

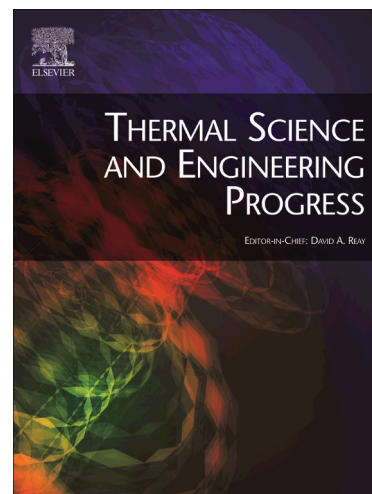

Please cite this article as: P. Regucki, M. Lewkowicz, R. Krzyżyńska, H. Jouhara, Numerical study of water flow rates in power plant cooling systems, *Thermal Science and Engineering Progress* (2018), doi: <https://doi.org/10.1016/j.tsep.2018.04.015>

This is a PDF file of an unedited manuscript that has been accepted for publication. As a service to our customers we are providing this early version of the manuscript. The manuscript will undergo copyediting, typesetting, and review of the resulting proof before it is published in its final form. Please note that during the production process errors may be discovered which could affect the content, and all legal disclaimers that apply to the journal pertain.

Numerical study of water flow rates in power plant cooling systems

Paweł Regucki¹, Marek Lewkowicz¹, Renata Krzyżyńska², Hussam Jouhara³

¹Faculty of Mechanical and Power Engineering, Wrocław University of Science and Technology, Poland

²Faculty of Environmental Engineering, Wrocław University of Science and Technology, Poland

³College of Engineering, Design and Physical Sciences, Brunel University London, Uxbridge, Middlesex UB8 3PH, London, UK

Abstract

The paper presents a mathematical model for studying series-parallel hydraulic systems. The analytical approach is based on a set of non-linear algebraic equations solved using numerical techniques. As a result of the iterative process, a set of volumetric flow rates is obtained for the water flows through all the branches of the hydraulic system investigated. As examples of the practical applications, the following are investigated: a cooling system of a power boiler's auxiliary devices and a closed cooling system containing condensers and cooling towers. In the first example, the calculations show the influence of changes in the characteristics of circulating pumps or elbows on the total cooling water flow rate in the installation analyzed. Such an approach makes it possible to analyze different variants of the modernization of the system studied, as well as to indicate its critical elements. In second case, knowledge about the water distribution in the cooling system can improve cooling processes inside cooling towers and, in this way, have a direct influence on better pressure conditions inside condensers. The results of numerical modelling are useful during modernization of the installation. By examining various solutions, an investor can choose the optimal variant of the reconstruction of the installation from the economic point of view.

Keywords:

cooling system, power plant, mathematical modeling, water management

1. Introduction

In all types of power plants, cooling installations play a significant role in the electricity production process. They are utilized to remove waste heat (e.g. a cooling system including condensers and cooling towers) or protect a boiler's auxiliary equipment against overheating. Regardless of the intended use, the cooling installation can always be divided into two parts: a series-parallel system (consisting of pipelines and pumps) which transports the cooling medium and heat exchangers responsible for heat transfer processes. Hydraulic systems with cooling water are designed according to optimization criteria in order to achieve maximum flow rates for the nominal thermal output of the power unit if it is operating under standard thermodynamic conditions (Malek 2007).

However, a gradual decrease of the overall efficiency of coal-fired power plants with time is observed (Campbell 2013). Among others, working parameters of hydraulic installations are subject to deterioration due to, for example, reconstruction of the system, deterioration of the circulating pumps' characteristics or deposition of mineral sediments inside pipelines. The above-mentioned changes cause a gradual decrease in flow rates in the cooling systems which cannot then achieve their design flow parameters. This situation is reflected in lower heat fluxes achieved in the heat exchangers (e.g. condensers, ash coolers) or higher outlet temperatures of the cooling medium. These negative changes also have an influence on the increase in the combustion of fossil fuels, which leads to an increase of the emission of greenhouse gases (GHG) and other pollutants to the atmosphere (Blog 2016).

In order to stop (or at least slow down) this trend, Ryabchikov *et al.* suggested a number of specific actions, among which the retrofit of cooling water installations is one of the most important (Ryabchikov 2012). Nichols *et al.* estimated that the modernization of cooling system performance in American power plants could lead to an improvement in the overall efficiency of the unit by about 0.2 – 1.0% (Nichols 2008). Similar estimations, made for APEC countries, indicate that the improvement of feed water heaters and condensers could enhance the

overall power unit efficiency by a value of approximately 0.8% (Boncimino 2005).

On the other hand, the cooling systems also are significant consumers of freshwater. For example, Zhai *et al.* reported that coal-fired power plants account for 39% of all freshwater withdrawals in the U.S. Moreover, power plants with wet cooling towers utilized approximately 86% of plant water consumption for cooling (Zhai 2011). Also, Zhang *et al.* in (Zhang 2017) reported that in China approximately 11% of total industrial water consumption is utilized by coal-fired power plants. Within this amount of freshwater approximately 84% is consumed by plants with closed-cycle cooling systems. The increase in water reservoir responsibility together with high penalties for exceeding allowable wastewater limits forces companies to look for the optimal management of freshwater.

The efficient optimization process is always based on a scientific approach involving mathematical modeling and numerical methods which are widely used in water management (Skoczko 2017). On the other hand, the modernization of an existing cooling installation is usually an expensive solution. Therefore, such a decision should be preceded by a careful analysis of the various elements of the prospective reconstruction (Raja 2017, Loew 2016, Wróblewski 2013). The importance of these issues is reflected in the number of papers published recently (Souza 2018, Ma 2017, Zhu 2017, Shukla 2017). Some previous attempts of modeling of a cooling water system are also presented in (AlSaqoor 2017).

In this paper, a mathematical model is presented, which predicts water flow rates in various cooling installations existing in a power plant. As an example of its practical application, the Authors analyze the water flow rates in the ash cooling system and the cooling system containing condensers and cooling towers.

2. Mathematical model of a series-parallel cooling system

A hydraulic cooling installation usually consists of a number of elements connected to form a hydraulic network containing several or many interconnected branches. In the networks considered, the pipelines are arranged in series-parallel systems, which could be considered as a

subclass of the so called “mixed system” (Chybowski 2015). A convenient description of these networks can be provided in the language of graphs. The graphical nodes correspond to merging points where single flow devices are connected. Each flow device is linear in the sense that it links precisely two nodes, therefore can be represented as an edge on the graph. Each branch (edge) has specific geometrical and physical properties, such as diameter, length, or absolute roughness. These, as well as the installed fittings (like elbows, joints, valves), vary significantly and make it necessary to investigate each cooling system individually. A proper analysis should be based on both the measurements of the actual flow parameters and the development of a mathematical model of the network. The aim of the model is to obtain the values of the flow rates in individual pipe elements if the characteristics of the elements as well as the pressure difference applied to the system as a whole are known. Although each cooling installation has its own individual structure, it is possible to formulate general rules providing a set of non-linear algebraic equations for the unknown flow rates. This set of equations can be solved with standard iterative numerical techniques. As a result, the values of all volumetric flow rates of water through all branches of the hydraulic system under question are obtained. The rules providing the above-mentioned system of non-linear equations will be explained in the illustrative scheme of the simplest series-parallel hydraulic system presented in Fig. 1.

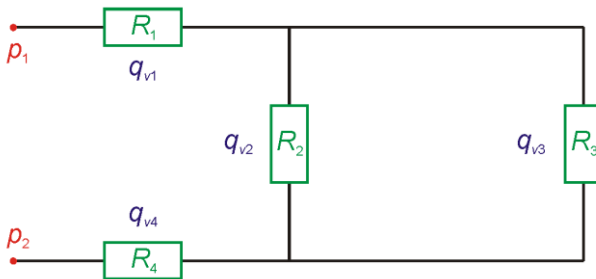

Fig. 1. Scheme of the simplest series-parallel hydraulic system (q_v - volumetric flow rate, R - flow resistance, p - absolute pressure)

Assume that our network exchanges working fluid at two particular nodes called inlet and outlet, and that the pressures at these nodes, denoted p_1 and p_2 , respectively, are known. The following three types of

equations will appear in our system. Each type is illustrated by an example conforming to the scheme presented in Fig. 1:

- Each graphical node (a joint occurring in the network), except the inlet and the outlet, provides a linear equation implied by the volumetric flow rate conservation law at the joint. Examples of the equations are $q_{v1} = q_{v2} + q_{v3}$ and $q_{v4} = q_{v2} + q_{v3}$. The two excluded nodes do not provide any equation as fluid can flow in or out of the network there.
- Each closed loop in the graph (a loop in the hydraulic system) provides an equation expressing the fact that the sum of the pressure drops around the loop must be zero. An orientation of the loop can be used to determine positive or negative signs for the pressure drops. Here some relation between the pressure drop Δp and the flow rate q_v at each edge (linear flow device) has to be adopted. The most common one is $\Delta p = R \cdot q_v^2$ with constant flow resistance R , although other choices, with variable R , are also possible. With this assumption, for the scheme in Fig. 1 the equation $R_3 \cdot q_{v3}^2 - R_2 \cdot q_{v2}^2 = 0$ is obtained.
- Each path connecting the inlet and the outlet of the system provides an equation which states that the pressure drop $\Delta p_{12} = (p_1 - p_2)$ between these two points equals the sum of pressure drops along the path. An example for the equation for Fig. 1 is $\Delta p_{12} = R_1 \cdot q_{v1}^2 + R_3 \cdot q_{v3}^2 + R_4 \cdot q_{v4}^2$.

Clearly, all nodes, loops and paths together provide more equations than necessary. A proper choice of the equations has to be made. The example presented in Fig. 1 requires four algebraic equations for determining the four unknown volumetric flow rates: q_{v1} , q_{v2} , q_{v3} and q_{v4} . It is easy to see that the four equations listed above will do so.

Now we indicate how to choose a proper independent set of equations. Let our graph have m edges and n vertices. The unknowns are the flow rates along the linear flow elements – the edges. Thus, their number is m . The first type of equations are equations corresponding to nodes, except the inlet and the outlet. We take all of them. Their number is $(n - 2)$. The second type of equations corresponds to loops. Clearly they are not all independent because composition of two loops a and b , that is the loop obtained by traversing a first, then b , provides an equation, which is the sum of equations provided by a and b separately. Let r be the circuit rank of the graph. This is the maximal number of independent loops (Jungnickel 2013). We select a maximal family of independent loops and

take one equation for each loop. Thus, we get r equations. Finally, we take one equation of the third type – any path joining the input and the outlet will be suitable. Together we have $(n + r - 1)$ equations. Now the basic relation satisfied by the circuit rank r is $(r = m - n + c)$, where c is the number of connected components. As our graph is connected, $c = 1$, and $(n + r - 1 = m)$, we obtain as many equations as unknowns. This does not prove that the system has a unique solution, but may be treated as a strong indication of this.

In many applications the network is of a series-parallel form. If one assumes additionally that the flow resistances R_i are constant then an explicit closed-formula solution of the above-mentioned problem exists. In particular, this implies a unique solution of this non-linear system of equations. If either the network fails to be series-parallel or flow resistances R_i depend on the flow rate, one has to use iterative numerical methods, which provide approximate solutions only.

In the general situation, the values of the flow resistances of an individual branch of the installation are calculated as the sum of local minor and friction losses which depend on local volumetric flow rates q_{vi} (by relationship through Reynolds number Re) (White 2010):

$$R_i = \frac{8 \rho}{\pi^2 d_i^4} \left(\sum_k \xi_{i,k} + \lambda_i(q_{vi}, k_i) \cdot \frac{l_i}{d_i} \right) \quad (1)$$

where: ρ – density of cooling medium, $\xi_{i,k}$ – coefficients of minor losses and λ_i – coefficient of friction losses which occur on “ i ” branch; d_i , l_i and k_i – diameter, length and absolute roughness of the “ i ” branch, respectively. The values of ξ coefficients are usually selected based on data from the literature or measurements. The values of λ coefficients are calculated from the Colebrook-White formula in the range of turbulent flow for a given absolute roughness k_i (White 2010). It is worth mentioning that the formula for λ includes information about q_v , which is unknown before the algebraic equation system is solved. Therefore, the values of λ_i (and hence flow resistances R_i) must be updated in each iterative step.

Several iterative techniques for solving the system of non-linear algebraic equations are available. A standard approach is to use Newton’s method (Mathews 1999). Here the non-linear problem is iteratively approximated

pressure head $\Delta p = (p_1 - p_0)$ and total volumetric flow rate q_{v0} related to pressure drop $\Delta p_{12} = (p_1 - p_2) = (\Delta p + p_0 - p_2)$. The main purpose of this installation is to deliver cooling water to two bottom ash coolers (marked in Fig. 2 by red boxes) which cool down the slag removed from the circulating fluidized bed boiler. The detailed description of the construction and functioning of these heat exchangers is presented in (Regucki 2017). The side ash coolers are occasionally used in cases when the mass of removed slag is too large and bottom ash coolers cannot properly cool it down. Apart from that, cooling water from the main pipeline is also delivered to the boiler's auxiliary equipment: two cameras and three fan bearings.

In order to analyze the flows through the hydraulic system, eighteen values of volumetric flow rates q_{vi} are required and so the mathematical model of the installation consists of eighteen algebraic equations:

- five equations which describe volumetric flow rate conservation at individual joints (e.g., $q_{v1} = q_{v11} + q_{v12}$),
- four equations which describe pressure losses in individual loops (e.g. $R_2 \cdot q_{v12}^2 - R_1 \cdot q_{v11}^2 = 0$),
- nine equations which describe the pressure drop Δp along selected paths connecting the inlet and the outlet of the system (e.g., $\Delta p_{12} = (p_1 - p_2) = (R_{14} + R_{18}) \cdot q_{v1}^2 + R_1 \cdot q_{v11}^2 + R_{31} \cdot q_{v0}^2$).

It is worth mentioning that the proposed system of algebraic equations is not a unique one and one can write down other systems with a different number of equations which still describe the loops and paths. The system of the above-mentioned algebraic equations was solved by applying Newton's method with precision $\varepsilon = 10^{-3}$.

The validation of the mathematical model was based on the measurement data obtained from the real installation. Table 1 presents a comparison of the numerical results with the measurements for eight values of volumetric flow rates q_{vi} (for current $\Delta p = 0.325$ MPa). Notation in the table is compatible with the symbols used in Fig. 2.

Table 1. Comparison of numerical results with measurements for eight values of volumetric flow rates q_{vi} (in m^3/h). Notation is compatible with the symbols used in Fig. 2

	q_{v0}	q_{v1}	q_{v2}	q_{v3}	q_{v4}	q_{v5}	q_{v6}	q_{v7}
Measurement, [m^3/h]	180.0	4.1	0	11.5	51.9	46.5	62.2	11.4
Numerical results, [m^3/h]	183.9	3.7	0	10.6	48.8	43.5	66.7	10.6
Relative error, [%]	2.17	-9.76	-	-7.83	-5.97	-6.45	7.23	-7.02

An analysis of volumetric flow rates q_{vi} shows good agreement of the corresponding values with individual relative errors smaller than 10%. It is worth mentioning that during measurements the right side ash cooler was not working. Hence, the volumetric flow rate q_{v2} in the mathematical model was put zero. Based on the results of the numerical calculations the characteristic of the total volumetric flow rate q_{v0} in the system was created and compared with the nominal characteristics of the circulating pump (green and blue lines in Fig. 3, respectively).

An analysis of the nominal and actual working point of the cooling system clearly indicates a lower current value of total volumetric flow rate q_{v0} than the one for which it was initially designed. This discrepancy could be connected with a gradual deterioration of the rotor of the circulating pump or contamination of pipelines and heat exchanger surfaces by mineral deposits resulting from many years of operation. The effect of the decrease in flow by $\Delta q_{v0} = 11.9 \text{ m}^3/\text{h}$ is mainly reflected in the deterioration of the heat exchanger efficiency inside the bottom ash coolers. Lower flow rates of cooling water also result in higher outlet temperatures of the slag which could have negative consequences during its subsequent transport and storage.

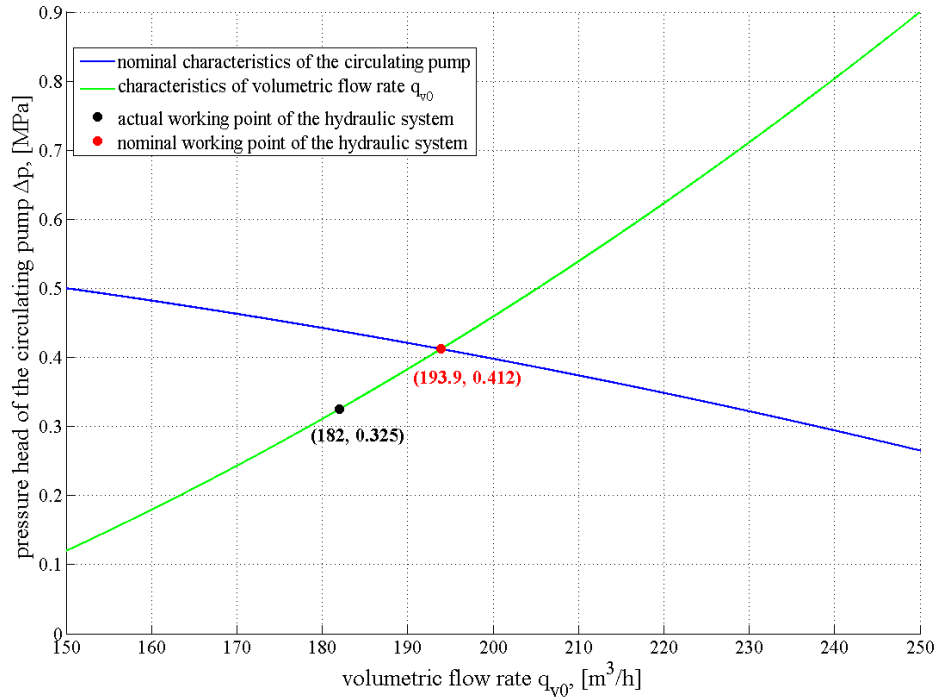

Fig. 3. Comparison of the characteristic of the total volumetric flow rate q_{v0} obtained from numerical calculations with nominal characteristics of the circulating pump (green and blue lines, respectively). The actual and nominal working points are marked by black and red circles, respectively

3.1. Variants of installation improvement

The mathematical model was used to analyze different concepts which could improve the total volumetric flow rate q_{v0} in the cooling system. As an example of the calculations, two possible modifications are presented: implementation of a more powerful circulating pump and replacement of all elbows by so-called “Hamburg bends”.

The first variant does not interfere with the existing structure of the cooling system, increasing only the pressure head of the new pump Δp . Table 2 presents a comparison of the total volumetric flow rates q_{v0} achieved for different pump discharges: 0.62, 0.80 and 1.00 MPa, respectively.

Table 2. Comparison of the total volumetric flow rate q_{v0} (in m^3/h) achieved for different pump discharges

Pump discharge, [MPa]	actual state	0.62	0.80	1.00
Volumetric flow rate q_{v0} , [m^3/h]	182.0	193.9	213.9	229.5
Pressure drop Δp , [MPa]	0.325	0.412	0.571	0.706
Increase of q_{v0} , [%]	-	6.3	17.5	26.1

Data presented in Table 2 show that the replacement of the existing circulating pump by a new one always improves the total volumetric flow rate q_{v0} of cooling water in the system. It is worth noting that the volumetric flow rate q_{v0} does not increase linearly with the increase in the pump discharge. Comparing the increases in q_{v0} for the listed pump discharges, the most promising improvement is achieved for the pump discharge equal to 0.8 MPa because the flow rate q_{v0} increased about $31.9 \text{ m}^3/\text{h}$ (17.5%). The further improvement between the pump discharges of 0.8 and 1.0 MPa is rather less, only 8.6%. Note that the higher volumetric flow rate q_{v0} (forced by a higher pump discharge) results in higher velocities in individual branches of the system and that causes an increase in individual flow resistances R_i . This situation is reflected by a higher pressure drop Δp in the system.

The second variant analyzed here is the replacement of all elbows by the so called “Hamburg bends” and their influence on the total volumetric flow rate q_{v0} , while keeping the present circulation pump in the system. This modification was suggested by the observation that there are 164 elbows in the cooling installation. In the literature, one can find that the coefficient of minor losses for elbows ξ could vary between (0.8 - 1.3) depending on shape and diameter. Initially in the mathematical model the value of $\xi = 1.2$ was used, which corresponded well with pressure drops in the individual branches. Then the mathematical model was modified by implementing the “Hamburg bends” coefficient of minor losses ξ equal to 0.4. After this modification the result of numerical calculations showed that the total volumetric flow rate q_{v0} increased only by approximately 8.3%. The improvement is at the same level as in case of the replacement of the pump by a new one (with pump discharge 0.62

MPa). Additionally, volumetric flow rates to bottom and side ash coolers increased by only 8%.

Analyzing the results of these two examples of potential modifications of the cooling system, the investor can assess which variant of the modification is more cost-effective by comparing the investment costs and the expected improvement in the volumetric flow rate of cooling water q_{v0} . Other variants of modification of the cooling system are presented in (Regucki 2017).

4. Closed cooling system including condensers and cooling towers

Closed cooling systems usually operate with power units in cases when power plants are located far away from large natural freshwater reservoirs. The daily water demand for such an installation often reaches the level of several thousand cubic meters, and so the proper management of freshwater has strong influences not only on the energy production process but also on the optimization of wastewater treatment. Knowledge about water distribution in the cooling system can improve cooling processes inside cooling towers and, in this way, has a direct influence on better pressure conditions inside condensers. An example of the closed hydraulic system which transports cooling water between condensers and cooling towers is presented in Fig. 4.

Warm water from condensers is pumped to the cooling system by twelve pipelines denoted as external volumetric flow rates ($q_{vz1} - q_{vz12}$) and is next distributed to five cooling towers (marked with red circles). Inside each cooling tower, water is additionally divided between a core and ring sections ($\{R_{28}, R_{31}, R_{34}, R_{37}, R_{40}\}$ and $\{R_{29}, R_{32}, R_{35}, R_{38}, R_{41}\}$ respectively). The aim of the mathematical model was to determine the values of volumetric flow rates q_{vi} to individual cooling towers. To do this, a set of 41 non-linear algebraic equations was created:

- 28 equations describe water distribution in individual joints,
- 4 equations describe pressure losses in the closed hydraulic loops,
- 9 equations describe the pressure drop along pipelines connected to two outlets of the system (paths).

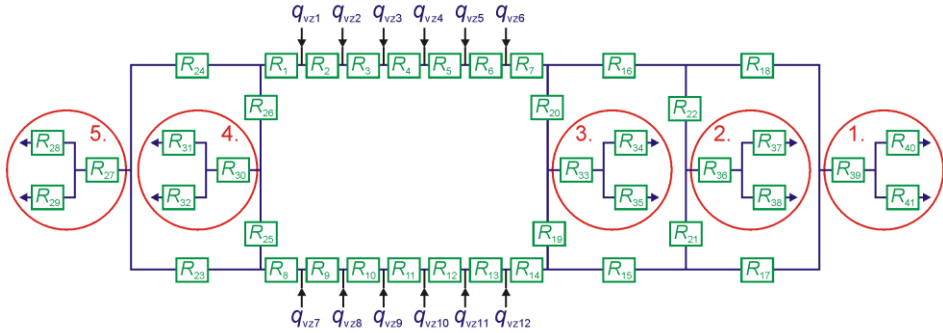

Fig. 4. Scheme of the series-parallel cooling system including five cooling towers (red circles). Volumetric flow rates from condensers are denoted by q_{vz}

The values of flow resistances R_i were calculated based on the technical documentation and data from literature. Due to the fact that the pipelines are made from concrete, the values of the friction loss coefficients λ_i in (1) are calculated for absolute roughness $k = 10^{-4}$ m (White 2010). The complexity of the hydraulic system makes it hard to estimate the direction of the flows in individual branches at first sight. Therefore, in equations describing the pressure drop, the terms (q_{vi}^2) had to be replaced by the expressions $(q_{vi} \cdot |q_{vi}|)$, which not only enable the determination of the value of q_{vi} but also the direction of the flow (through the positive or negative sign of q_{vi} values). So, during the iteration process, the initial directions of the volumetric flow rates are adjusted to satisfy the equations of the mathematical model. It is worth mentioning that for an open hydraulic installation it is not necessary to know the pressure at the inlet of the external volumetric flow rates q_{vz} because equations describing the pressure drop can be derived between the outlets of the system (which have atmospheric pressure). The system of the above-mentioned algebraic equations was solved by applying Newton's method with precision $\varepsilon = 10^{-3}$.

4.1. Numerical results and discussion

The values of flow rates q_{vzi} (see Fig. 4), which were used as the input parameters to the mathematical model, came from the measurements done on the real object and are listed in Table 3. The total external volumetric flow rate in the system was $152,800 \text{ m}^3/\text{h}$.

Table 3. The input values of volumetric flow rates q_{vzi} used in the mathematical model. The total external volumetric flow rate was 152,800 m³/h.

	volumetric flow rate measurement, [m ³ /h]		volumetric flow rate measurement, [m ³ /h]
q_{vz1}	12741	q_{vz7}	12735
q_{vz2}	12724	q_{vz8}	12709
q_{vz3}	12733	q_{vz9}	12751
q_{vz4}	12744	q_{vz10}	12738
q_{vz5}	12722	q_{vz11}	12730
q_{vz6}	12732	q_{vz12}	12741

The most interesting values obtained from the mathematical model are the volumetric flow rates to individual cooling towers denoted by: q_{v27} , q_{v30} , q_{v33} , q_{v36} and q_{v39} . Table 4 presents a comparison of the numerical calculations with measurement data obtained from the actual installation.

Table 4. Comparison of measurements and the numerical results from the mathematical model of the closed cooling water system. The total external volumetric flow rate was 152,800 m³/h.

cooling tower	volumetric flow rate measurement, [m ³ /h]	volumetric flow rate numerical result, [m ³ /h]	relative error, [%]
1 (q_{v39})	26511	27290	-2.94
2 (q_{v36})	32836	29445	10.33
3 (q_{v33})	23669	24861	-5.04
4 (q_{v30})	33937	37023	-9.09
5 (q_{v27})	35847	34181	4.65

The data presented indicate that the largest discrepancies between the measurements and numerical simulation are for the second and fourth cooling tower. The maximum value of the relative error is at the level of 10%. This is a very good agreement, taking into account the complexity of the series-parallel system reflected in the number of non-linear algebraic equations. The validated model allows one to predict the

changes in flow rates when, for example, one of the power units or cooling towers is turned off. It is especially important in the case when cooling towers have different cooling characteristics and a proper distribution of warm water could result in the highest possible temperature drop in the cooling water. As a result, colder water would produce a better vacuum inside condensers and, in this way, improve the efficiency of the electricity production process in the power unit.

6. Conclusions

The examples of calculations presented indicate that mathematical models are useful and reliable tools for analyzing flows in different types of hydraulic systems. After a validation process, the models can be used to verify possible variants for retrofits of cooling installations as well as to indicate, for example, its critical elements or the directions of the flows in individual branches. This information could be valuable for investors who would like to make rational investment decisions related to the modernization of the hydraulic installation. Moreover, the software based on the mathematical models can be implemented to the monitoring system of power units and used for diagnostics for the system, indicating the deviations from its nominal operation.

Acknowledgement

This work was supported by Faculty of Mechanical and Power Engineering and Faculty of Environment Engineering (0401/0007/17); Wrocław University of Science and Technology.

References

- AlSaqoor, S., Alahmer, A., Andruszkiewicz, A., Kubas, K., Regucki, P., Wędrychowicz, W. (2017). Numerical modeling for the retrofit of the hydraulic cooling subsystems in operating power plant, *Thermal Engineering Journal*, 64(8), 551–558.
- Blog, S. F. (Last cited 4 January 2016). Message to EPA: Time to Modernize America's Power Plants - Cooling Systems Included. http://switchboard.nrdc.org/blogs/sfleischli/message_to_epa_it_is_time_to_m.html
- Boncimino, G., et al. (June 2005). Costs and effectiveness of upgrading and refurbishing older coal-fired power plants in developing APEC economies. *Asia-Pacific Economic Cooperation, Energy Working Group Project EWG 04/2003T*. www.egcfe.ewg.apec.org/projects/UpgradePP_Report_2005.pdf

- Campbell, R. J. et al. (2013). Prospects for coal in electric power and industry. *Tech. rep., Congressional Research Service Report*, R42950.
- Chybowski L., Żółkiewski S. (2015). Basic reliability structures of complex technical systems. *New Contributions in Information Systems and Technologies. Advances in Intelligent Systems and Computing*. Springer International Publishing, vol. 354, pp. 333-342, DOI 10.1007/978-3-319-16528-8_31
- Cross, H. (1930). Analysis of flow in networks of conduits and conductors. *Univ. of Illinois Engr. Exp. Sta. Bull* 286.
- Henderson, C., Baruya, P. (July 2012). CO₂ reductions from CCTs and CO₂ capture. *CCC/200, IEA Clean Coal Centre*, London, UK.
- Jungnickel, D. (2013). *Graphs, networks and algorithms*. Springer Verlag Berlin Heidelberg ISBN 978-3-642-32277-8.
- Loew, A., Jaramillo, P., Zhai, H. (2016). Marginal costs of water savings from cooling system retrofits : a case study for Texas power plants. *Environmental Research Letters*, 11 (10), p. 104004.
- Ma, J., Wang, Y., Feng, X. (2017). Simultaneous optimization of pump and cooler networks in a cooling water system. *Applied Thermal Engineering*, 125, 377-385.
- Malek, M. A. (2007). *Heating boiler operator's manual: maintenance, operation and repair*. New York: McGraw-Hill companies.
- Mathews, J. H., Fink, K. D. (1999). *Numerical methods using Matlab*. New York: Prentice Hall.
- Nichols, C., et al. (2008). Reducing CO₂ emissions by improving the efficiency of the existing coal-fired power plant fleet. *US Department of Energy National Energy Technology Laboratory, DOE/NETL-2008/1329*.
- Raja, B.D., Patel, V., Jhala, R.L. (2017). Thermal design and optimization of fin-and-tube heat exchanger using heat transfer search algorithm. *Thermal Science and Engineering Progress*, 4, 45-57, DOI: 10.1016/j.tsep.2017.08.004
- Regucki, P., Lewkowicz, M., Kucięba, M. (2017). Numerical modelling of series-parallel cooling systems in power plant. *E3S Web of Conferences*, 22, 00144. DOI: 10.1051/e3sconf/20172200144
- Ryabchikov, A., et al. (2012). Modernization of heat exchangers in steam turbine units taking features of their operation at specific thermal power plants into account. *Power Technology and Engineering*, 44 (3), 208-212.
- Shukla, S.K., Samad, N.A.M., Ghosh, S. (2017). CFD simulation of steam condensation in a subcooled water pool. *Thermal Science and Engineering Progress*, 2, 80-86, DOI: 10.1016/j.tsep.2017.04.006
- Skoczko, I., Struk-Sokolowska, J., Ofman, P. (2017). Modelowanie zmian

- parametrów ścieków oczyszczonych z wykorzystaniem sztucznych sieci neuronowych. *Rocznik Ochrony Środowiska*, 19, 633-650.
- Souza, J. N. M., Levy, A. L. L., Costa, A. L. H. (2018). Optimization of cooling water system hydraulic debottlenecking. *Applied Thermal Engineering*, 128, 1531-1542.
- White, F.M. (2010). *Fluid mechanics*. New York: McGraw-Hill companies.
- Wróblewski, W., Dykas, S., Rulik, S. (2013). Selection of the cooling system configuration for an ultra-critical coal-fired power plant. *Energy Conversion & Management*, 76, 554-560.
- Zhang, X., *et al.* (2017). China's coal-fired power plants impose pressure on water resources. *Journal of Cleaner Production*, 161, 1171-1179.
- Zhai, H., Rubin, Ed. S., Versteeg, P. L. (2011). Water use at pulverized coal power plants with postcombustion carbon capture and storage. *Environmental Science & Technology*, 45 (6), 2479-2485.
- Zhu, X., *et al.* (2017). Integrated modeling and operation optimization of circulating cooling water system based on superstructure. *Applied Thermal Engineering*, 127, 1382-1390.

Highlights:

- The presented mathematical models can be useful and reliable tools for analyzing flows in different types of hydraulic systems
- The models can be used to verify possible variants for retrofits of cooling installations and indicate its critical elements or the directions of the flows in individual branches
- The software based on the mathematical models can be implemented to the monitoring system of power units and used for diagnostics for the system, indicating the deviations from its nominal operation