

Accepted Manuscript

Title: Interoperable Internet-of-Things Platform for Smart Home System using Web-of-Objects and Cloud

Authors: Asif Iqbal, Farman Ullah, Hafeez Anwar, Kyung Sup Kwak, Muhammad Imran, Waseef Jamal, Atta ur Rahman



PII: S2210-6707(17)31337-9
DOI: <https://doi.org/10.1016/j.scs.2018.01.044>
Reference: SCS 957

To appear in:

Received date: 4-10-2017
Revised date: 23-1-2018
Accepted date: 23-1-2018

Please cite this article as: Iqbal, Asif., Ullah, Farman., Anwar, Hafeez., Kwak, Kyung Sup., Imran, Muhammad., Jamal, Waseef., & Rahman, Atta ur., Interoperable Internet-of-Things Platform for Smart Home System using Web-of-Objects and Cloud. *Sustainable Cities and Society* <https://doi.org/10.1016/j.scs.2018.01.044>

This is a PDF file of an unedited manuscript that has been accepted for publication. As a service to our customers we are providing this early version of the manuscript. The manuscript will undergo copyediting, typesetting, and review of the resulting proof before it is published in its final form. Please note that during the production process errors may be discovered which could affect the content, and all legal disclaimers that apply to the journal pertain.

Article

Interoperable Internet-of-Things Platform for Smart Home System using Web-of-Objects and Cloud

Asif Iqbal¹, Farman Ullah², Hafeez Anwar², Kyung Sup Kwak¹, Muhammad Imran³, Waseef Jamal⁴, Atta ur Rahman⁴

¹Department of Information and Communication Engineering, Inha University, Incheon, South Korea

²Department of Electrical Engineering, COMSATS Institute of Information Technology, Attock, Pakistan

³Department of Computer Science, Sarhad University of Science & IT, Peshawar, Pakistan

⁴Institute of Management Sciences, Peshawar, Pakistan

E-mail: asifsoul@gmail.com; farmankttk@ciit-attock.edu.pk; hafeez.anwar@ciit-attock.edu.pk; kskwak@inha.ac.kr; imran.csit@suit.edu.pk; waseefjamal@imsciences.edu.pk; attaurrahman@imsciences.edu.pk

Highlights of the Paper

- Proposed an interoperable and flexible internet-of-things platform for smart home system using web-of-objects and cloud infrastructure
- Provided Raspberry PI based gateway for interoperability among various legacy home appliances, different communication technologies, and protocols.
- RESTful based smart home system to assign a unique URIs to each sensor data and an actuator event to reduce the processing at the webserver
- Provided the cloud server for smart homes' to store the homes' data due to low storage capabilities at a gateway and providing the data for various application's service providers and analysis

Abstract: Recent advancements in the Internet, web and communication technologies cut across many areas of modern-day living and enabled interconnection of every physical object, including, sensors and actuators. Web-enabled smart objects empower innovative services and applications for different domains and improve utilization of resources. In this paper, we propose an interoperable Internet-of-Things (IoTs) platform for a smart home system using a Web-of-Objects (WoO) and cloud architecture. The proposed platform controls the home appliances from anywhere and also provides the homes' data in the cloud for various service providers' applications and analysis. Firstly, we proposed a Raspberry PI based gateway for interoperability among various legacy home appliances, different communication technologies, and protocols. Secondly, we bring the smart home appliances to the web and make it accessible through the Representational State Transfer (REST/RESTful) framework. Thirdly, we will provide the cloud server for smart homes' to store the homes' data due to low storage capabilities at a gateway and provide the data for various application's service providers and analysis. In the proposed smart home platform, we implement a water-tank control using Zigbee communication, an automatic door security using a normal camera as an IP camera, and provide web connectivity to different home devices for web-based controlling. We aim to reduce the human intervention, secure access control to home devices from anywhere, provide smart homes data for application services as well as for analysis, and improve the utilization of resources.

Keywords: Internet-of-Things; Web-of-Objects; Smart home; RESTful; Raspberry PI; Gateway

1. Introduction

The advancements in Internet and web technologies provide a platform to users to create and consume information. In last decade, the research has focused on the connectivity of all physical objects and information environment to the Internet for enabling a user to access and control things from anywhere and at any time. This revolution coined the term's Internet of Things (IoTs) [1] and the Internet of Everything (IoE) [2]. IoTs and IoE make smaller objects or things more intelligent and more connected, to perform complex tasks. The IoT is rapidly gaining ground in service and application of latest wireless and wire communications. Also, the IoT is a dynamic and adaptive global information network of a home or a city composed of Internet-connected things and objects, such as sensors, actuators, Auto-IDs, radiofrequency identifications and physical objects, as well as other organizations and smart devices that are becoming a vital element of the Internet [4]. However, they lack standardization at the application level. Web of Objects (WoOs) [3] objectifies and virtualizes the assorted real-world objects to support intelligent features by representing them as Web resources, which can be accessed using lightweight Application Programming Interface (APIs) based on the Representational State Transfer (REST) principles [5] [6]. To efficiently utilize the resources in a smart home environment, the entire home devices should be interconnected and provide connectivity to the end user in order to control it from anywhere and anytime. IoT is converting the smart cities and smart homes from hype into reality. A smart home is the basic and

major building block of implementing the smart cities [7]. In this paper, we suggest an interoperable IoTs platform for home devices control using the WoOs concepts. Fig.1 shows the conceptual overview of the smart home control using WoOs and cloud. The proposed architecture framework provides the interoperability among various legacy devices and brings the home appliances on the Web so that we can control any device from anywhere.

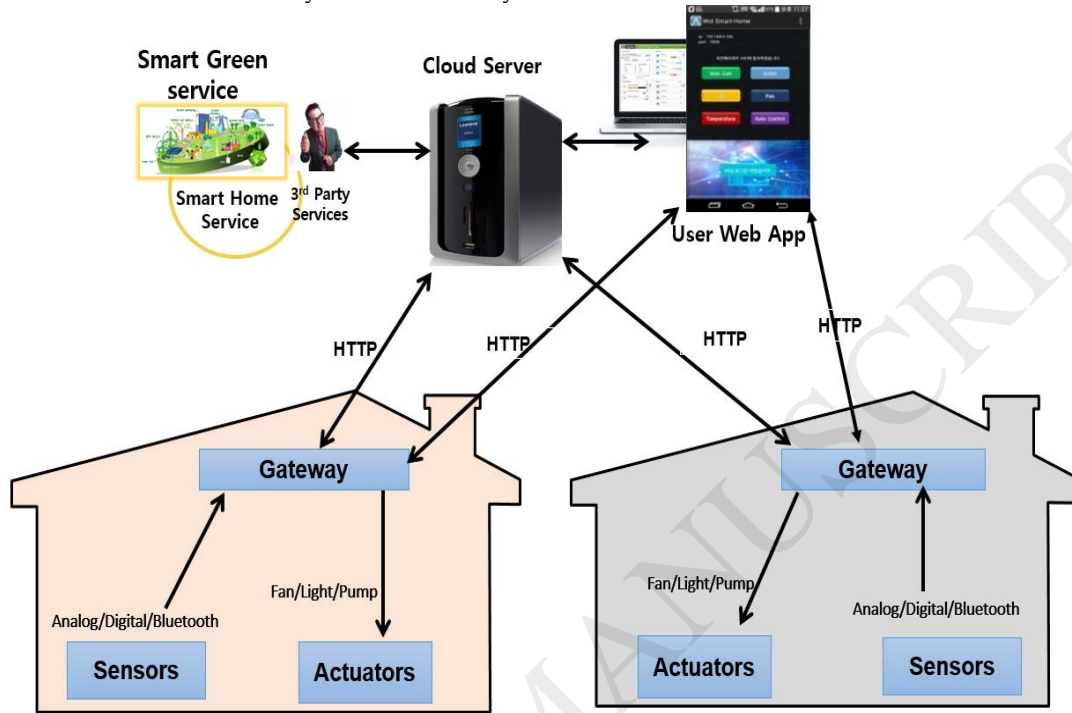

Figure 1. Conceptual Overview of Smart Home System Using Web-of-Objects and Cloud

In 1990, the phrase smart home was first coined. The survey reported by [8] stated that users had shown a positive perception of the smart home technologies aligned to their requirements such as managing energy use, control of the domestic environment, and improving security. This positive perception confirms a strong market potential for smart home technologies. The technological trends of IoTs and WoTs show that the next-generation smart home environment will be ubiquitous, pervasive, and perceptual. The pervasive systems without user interaction support will not exist, and the system which is difficult to use, obtrusive and subject to risks, will not be used by users [9]. Smart home embeds computing capabilities, networking, and telecommunication interfaces in the home appliances in order to facilitate everyday life. The smart home environment comprises sensors, actuators, interfaces, and appliances networked together to provide localized and remote control of the environment. Sensing and monitoring of environment include temperature, humidity, light, and motion. Environment control such as heater and fan ON/OFF control is provided by the actuator having dedicated hardware interfaces and computing capabilities. Localized control is provided by Bluetooth and remotely access through WiFi. In this paper, we propose web-based control using Hypertext Transfer Protocol (HTTP) and Representational State Transfer (RESTful) framework for water pump/tank control through Zigbee communication, door control using motion sensor and converting a normal camera as an IP-based camera, temperature and humidity based exhaust fan control, various power plugs control for lights, fans and air conditioners.

In a smart home ubiquitous environment, the heterogeneous sensing devices and the service's applications that use the sensor data often join or leave the network environment. The RESTful architecture enables interoperability in Smart Home Web of Objects Architecture (SWOA). RESTful is flexible to equip more diverse heterogeneous devices, resources and communication protocols to improve user satisfaction [10]. REST architecture leverages the integration of devices in the smart home environment and is more appropriate for resource-constrained, ad-hoc environments as it is a simple and flexible protocol that guarantees loose-coupling of resources. REST architecture style based applications and services can coexist and interoperate with legacy systems such as Simple Object Access Protocol (SOAP) based interfaces. In this paper, we provide the REST Uniform Resource Identifiers (URIs) for accessing each sensor and actuator data such as URIs: **lightON** and **lightOFF**.

Embedding sensors and actuators in the smart home environment generate a huge amount of raw data that must be gathered and processed to extract useful and relevant information for different services. Sensors and gateways at homes have very limited storage capabilities. Providing access to each home data for various services such as predicting the overall usage of electricity in a city increases complexity when data is stored at home level. Therefore cloud is an appropriate option to collect home's data of a community for analyzing data by various services. In a cloud, different data is gathered from multiple sources (such as user information, sensors data, actuators status, households' data on relevant time, etc.) [45-46]. For the upcoming generations of IoT applications, the cloud "promises high reliability, scalability, and autonomy" [11]. Providing different home service (electricity, gas and water etc.) the data for their easiness and also graphical view for home users is stored in the cloud, so they properly manage the utilization of services. In this paper, we provide the cloud as a central server and database to store the home's data to prevent it from loss and also provide it for analyzing and extracting relevant information.

The rest of the paper is organized as follow: section 2 provides the related works, background and literature review. Section 3 describes the proposed architecture of the smart home using WoO and cloud. Various real applications implementation scenarios, their details and algorithms are described in Section 4. Finally, we conclude the proposed work in section 5.

2. Background and Related works

In this section, we are introducing the background and related work about IoTs, Web of Things, smart homes, web services in smart homes, and the cloud services.

Intelligent control systems can potentially allow us to achieve a variety of benefits for human's daily living experience in the environments where they live and work [12]. IoT is a worldwide network of objects or things [13-15, 42], which enables the intelligent systems to control the objects either locally or remotely. In recent communication paradigm, every physical object has computing capabilities such as a microcontroller, communication interfaces, and suitable protocols stack in order to communicate the objects with each other's and also provide an interface to users, and become an integral part of the Internet. Atzori et al. [14] realized IoTs in three

paradigms—internet-oriented (middleware), things oriented (sensors) and semantic-oriented (knowledge). IoT vision is very broad and it includes a variety and almost every physical object. Objects may be personal devices such as smart phone, RFID tag, digital camera and tablets, and it may include objects from industry such as motors, machine and etc. Due to limited computing capabilities, small in size, and high mobility of objects in the IoT environment both the researchers and industries are focusing on low-power communication protocols based IoTs. Some of the assisting protocols are Bluetooth, IPv6 over Low-Power Wireless Personal Area Network, IEEE 802.15.4, and Constrained Application Protocol (CoAP) [16-17]. Yichao Jin et al. [43] proposed content centric routing protocol where the path for packet forwarding is determined by its content. A protocol is proposed [44] for survivable path routing in wireless sensor networking considering traffic congestion and node energy level. Mostly these protocols facilitate the physical objects connectivity at the network layer. But at the application layer, the interconnectivity of objects is still a challenging task due to the heterogeneity and incompatibilities of platforms [18-19].

In traditional approach, smart home is concentrated frameworks opted to a single-user where home devices are connected to the home network. Evolution of smart home started from centralized and semi-automated control of home devices, such as heater and light, using technology to monitor and generate events to control these devices. The main propose of the smart technology is to provide services such as health monitoring and caring [20], safety, security, greenhouse, and energy consumption reduction [21]. MavHome (Managing an Adaptive Versatile Home) had been developed [22-23] to control the home appliances more or less independently. The MavHome architecture has four layers i) decision, ii) information, iii) communication, iv) physical, and it is similar to most of the existing smart homes architecture. Physical layer consists of all the physical objects and its interfaces within the smart home environment. Communication layer is responsible of transferring the information between objects and also to the user. Information layer aggregates the data from sensors and actuators to be used for decision making and analysis. Decision layer extracts the knowledge from the information gathered and also uses the information implicitly provided for making decision of what action needed in what kind of scenario. Every smart home consists of smart objects called sensors and actuators that communicate with a central application. The central application has various terms in various domains such as smart home gateway [24], smart home controller [25], ZigBee based self-adjusting sensor [26], and distributed sensor gateway [27]. Basim Hafidh et al. [28] proposed SITE (The Simple Internet of Things Enabler for Smart Homes) a smart home that enable user to specify and control the smart home IoT objects centrally. In recent years, the researchers are also focusing on predicting algorithms for IoTs and smart home services [29]. Alam et al. [30] proposed SPEED (sequence prediction via enhanced episode discovery) prediction algorithm to classify the inhabitants' activities in the smart homes. Security and privacy are also major problems in IoTs and smart home environment [31-34]. The user identity should be anonymized and access to user's home appliances should be secured. It is provided through secure login and consent of the user. Smart objects and related communication technologies to enable an IP-based IoTs and the vision of IoT applications on Web is introduced in [39-40]. Another

independent study was provided by [41], the authors of study approved the smart home technology as the social world, the physical world and the information world (cyber world). The author focuses on the data cycle, namely “from things to data, information, knowledge, wisdom, services, humans, and then back to things”. It is believed that it clearly depicts the notion of Web of Things (WoT) in a practical way and is good at providing comfort to the users.

In the last decade, the merging of communication, computing, and human interaction technologies eases the accessibility of physical devices. Web capability in physical objects enables user to access it from anywhere and at any time. Muehlen et al. [35] discussed two standards for web services: SOAP and RESTful. SOAP is a general protocol used as an element of different web architectures and is tightly coupled designs similar to remote procedure calls. REST is architecture and is loosely coupled designs similar to navigating of web links. A middle-ware platform was proposed [6] to integrate heterogeneous devices and multi-scale systems-of-systems in ubiquitous and pervasive environment leveraging REST architecture style. The comparisons of REST and SOAP [35-37] showed that the REST architecture style services are more suitable for such environment in achieving scalability and high performance. Semantic ontology provides flexibility for the collaboration of computing devices in the ubiquitous environment. Semantic ontology helps ubiquitous environments to address key issues like knowledge representation, semantic interoperability, and service discovery and provides an efficient platform for building highly responsive and context-aware interactive applications [38].

Considering above literature review, the main contributions of the proposed paper can be summarized as (1) we proposed, WoO based smart home platform for controlling the home appliances from anywhere and also provides the homes' data at the cloud for various service providers' applications and analysis. (2) We provided a Raspberry PI based gateway for interoperability among various legacy home appliances, different communication technologies, and protocols. (3) We bring the home appliances to Web and make it accessible through the REST framework. (4) We provided the cloud server for smart homes' to store the homes' data due to low storage capabilities at a gateway and provide the data for various application's service providers and analysis.

3. The Proposed Architecture of Interoperable Internet-of-Things Platform for Smart Home System using Web-of-Objects and Cloud

In this section, we present the proposed interoperable architecture platform for IoTs of the smart home system using WoO and cloud. The proposed architecture incorporates the smart gateway that provides the interoperability among the protocols used by legacy home appliances. The gateway provides the web-connectivity to the legacy devices in order to access it from anywhere and at any time. It is an embedded device having low storage capability, so we provide the cloud-based server to store all the homes data that can be utilized for user history and also to third-party services providers and services data analyzers. The details of the proposed architecture and the different implemented service scenarios are explained in the below subsections.

3.1 Smart Home Architecture using WoO and Cloud platform

In the last decades, the merging of computing capabilities, communication interface and web-based user interfaces in physical objects have shown prominent improvement in development. However, mostly the home devices do not have the web interfaces to access it from anywhere and at any time. Fig. 2 shows the proposed architecture of smart home using the WoO and cloud platform. We interface different legacy devices using the non-IP and HTTP based interfaces such as GPIO (General Purpose Input/Output), ZigBee, Bluetooth, and Inter-Integrated Circuit (I²C) and Serial Peripheral Interface (SPI) buses. Raspberry PI based gateway is implemented to provide the interoperability between these protocols and also provides HTTP REST based interfaces for efficient resources utilization. We used the Python APIs to interface the sensors and actuators with the smart gateway.

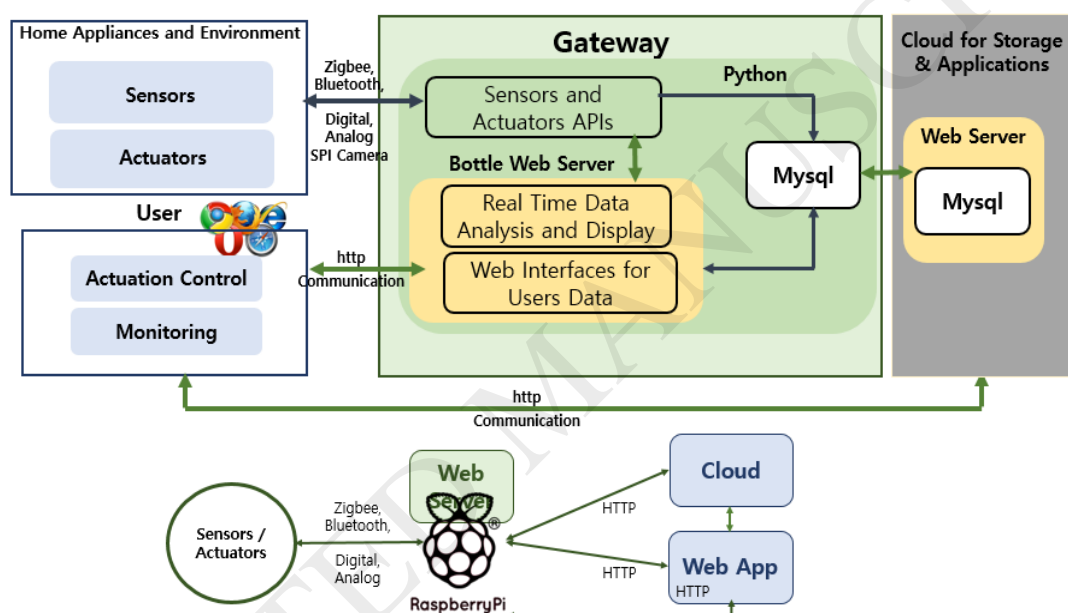

Figure 2. Proposed Architecture of Smart Home System Using Web-of-Objects and Cloud

The gateway has RESTful based Web-services that receive the user HTTP requests for different resources. Web services are based on the Resource Oriented Architecture (ROA) where physical objects and its events are assigned a URI to access it directly like a web hyperlink. We used Bottle web server, which is linked with Python where the real-time data analysis is performed, and Bottle server is connecting python with the Web App. Fig. 3 shows the detailed architecture for smart home using WoO and cloud architecture. All the sensors data are manipulated by the python and bottle server is used to get and post data using HTTP GET and POST methods. We used the database (MySQL) on the gateway to store the sensory and actuator data for temporary purpose and then backup the data to the cloud.

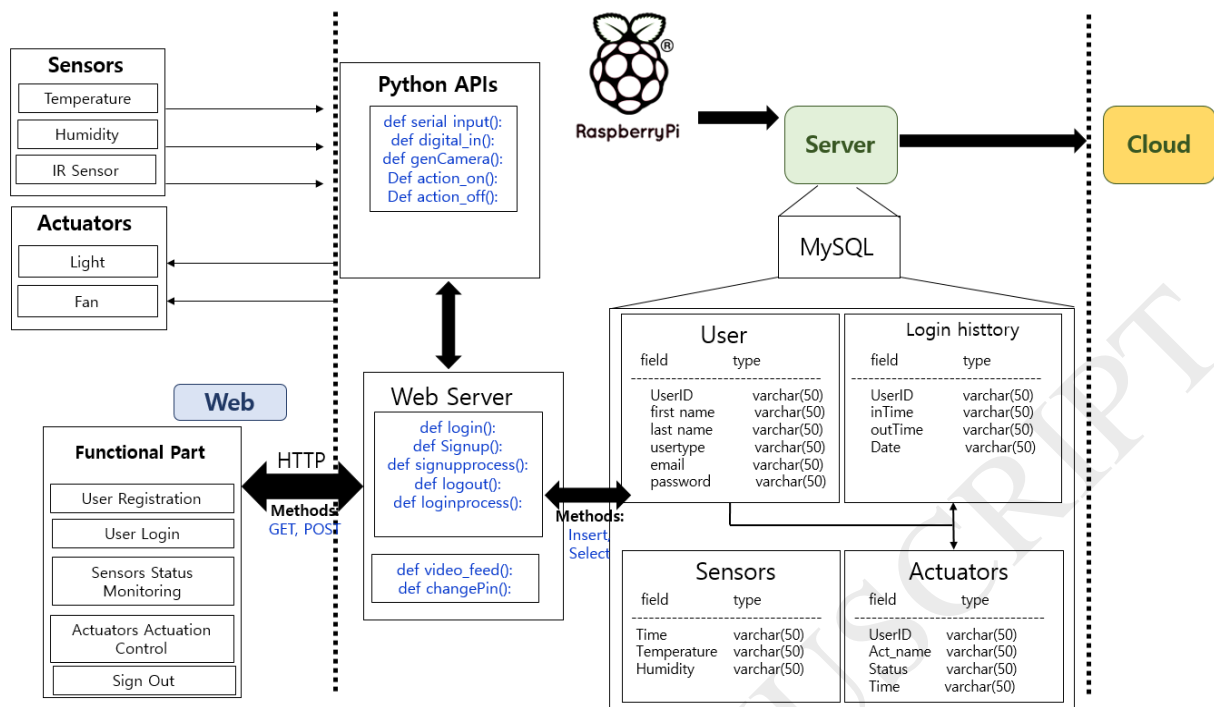

Figure 3. Detailed Architecture of Smart Home System Using Web-of-Objects and Cloud

In the proposed architecture, the web provides ubiquitous and pervasive services of application layer functionality to the smart home appliances. WoO provides a communication interface, which links the user to access directly the smart home objects. We provide RESTful ROA based URIs enabling access to each legacy device and its events. It enables the devices to speak each other and to the user same as other resources do on the web. Fig. 4 shows the overview of some RESTful URIs to access each home device and its function. The defined RESTful framework binds a URI to each physical object event and function. Using URIs, each sensor and actuator can be accessed directly. The user smart home Web application (Web_APP) generates an HTTP request such as to turn on a light (<http://10.0.103.57/16/on>) and is received by HTTP-enable web server (Bottle Web Server in our case). URI contains self-description of accessing object so the web server identifies the appropriate sensor or actuator controller such as the controller of /16. The controller translates HTTP message into Python functions to perform the specified task in URI and translates response into HTTP to send it to the Web_APP.

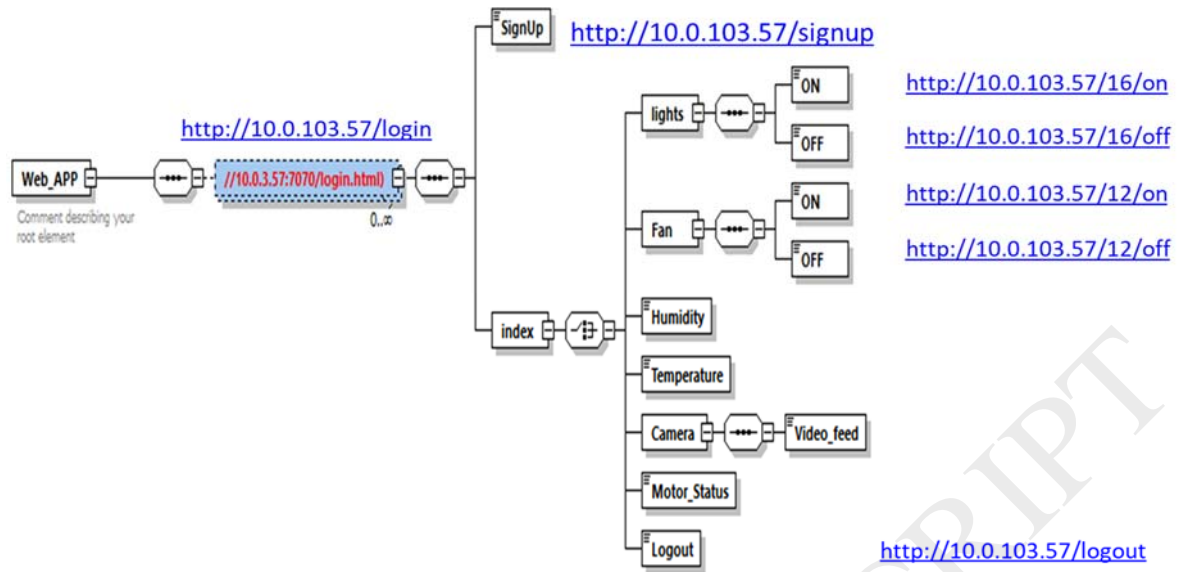

Figure 4. Overview of the RESTful Web URIs for the WoO based Smart Home Services

The proliferation of sensors and actuators in home environment generates a large-amount of raw data that can be utilized to extract useful and relevant information and relationships. Mostly home gateway has limited storage capability to store all raw data, and also we need a centralized storage for homes data to extract relevant and useful information for home and community services planning. In this paper, we provide a cloud server to store home data and provide information to the user and also to 3rd party service providers. Fig. 5 shows the database schema of the cloud server database to store the home users' data. The cloud server backups data from smart home gateway database periodically and delete data on the gateway. So the webserver on the gateway provides the real-time sensors data, actuators data, and control information. However, the reports and analyzed information are provided by the cloud webserver. Data and information to various service

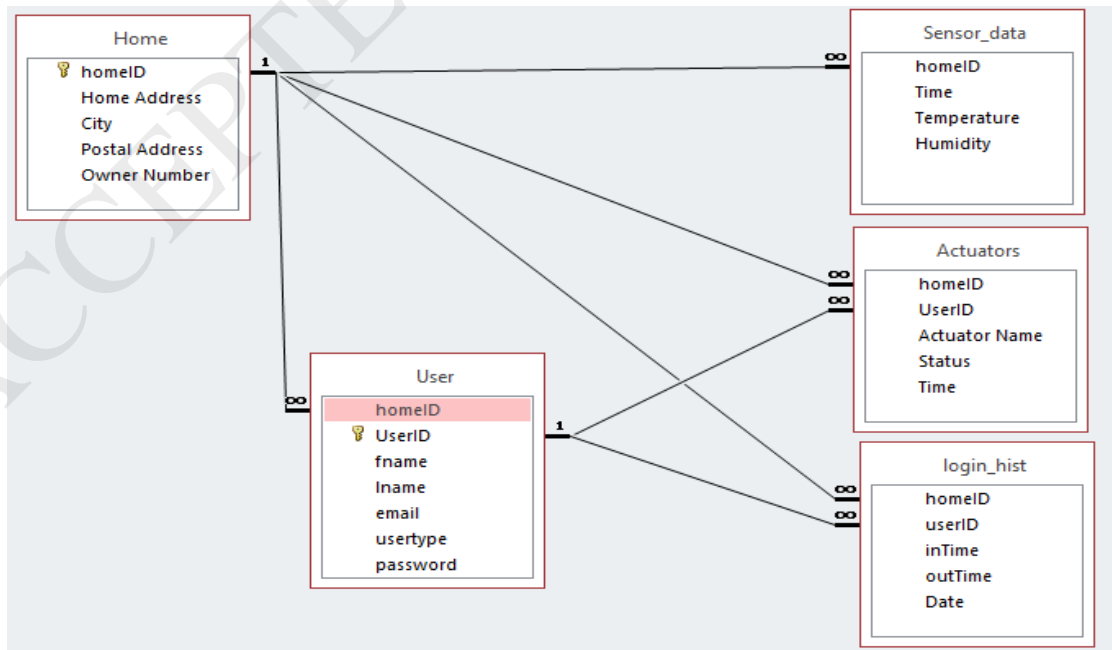

Figure 5. Overview of the Cloud Database storage for the home users' data

providers are received from the cloud storage database. The communication between cloud and home gateway is based on HTTP, and data is transferred in Extended Markup Language (XML) format to store it in a cloud server. To prevent data leakages and user privacy breaches, we store sensitive information in encrypted format.

3.2 Scenarios of Hardware Implementation of Smart Home Services and its Control

We implemented and provided different deliverables using the proposed interoperable IoT platform, and WoO and cloud. We develop the WoO based smart water tank control, WoO based door security control by changing normal camera to IP camera, WoO based lights and Fan control, and WoO based exhaust control using temperature and humidity sensors. In this subsection, we are going to explain in details the hardware implementation of each deliverable.

3.2.1 Web based door control using Raspberry PI camera as an IP camera, motion sensor and light control

We provide web-based door opening and security control by making the normal camera an IP based camera, motion detection sensor to identify the presence check at the door, and light control to take an image and store it for security reasons. Fig. 6(a) shows the connection and implementation of the proposed web-based door control using the raspberry pi camera as an IP camera. We interface a

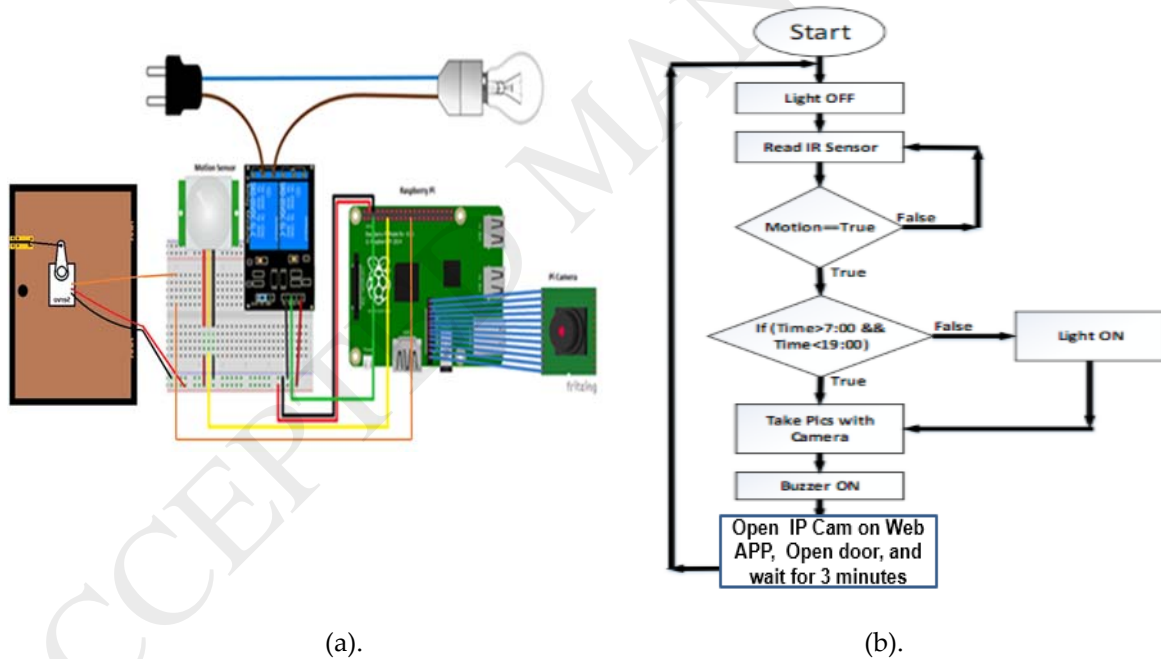

Figure 6. Web based door control using Raspberry PI camera as an IP camera, motion sensor and light control (a). Circuit diagram of web based door control (b). Flow chart of web based door control

Passive Infrared (PIR) sensor to detect the motion in front of a door, LED light, camera to take the image and a servo that acts as a lock of the door. When motion is detected by PIR, it sends a signal to the raspberry pi. Raspberry pi analyzed the signal and decide the time. If daytime, then no need to turn on a LED light, it just captures images and turns ON a buzzer. If a person is available at home he will open the door from the Web_APP, and the door lock is implementable by using the servo motor. After waiting for a pre-defined time the PIR sensor will start sensing again. The procedure of

web-based door security control is shown in the Fig. 6(b). The status of a door open and close is updated in the gateway database and also on the user Web_APP.

3.2.2 Web based Water Tank Control Using ZigBee Communication

The monitoring of water tank level is important and necessary to prevent the wastage and efficiently use of water and energy resources. We provide web based and automatically turn on/off water pump control. Fig. 7 shows water tank control using Zigbee communication between sensors

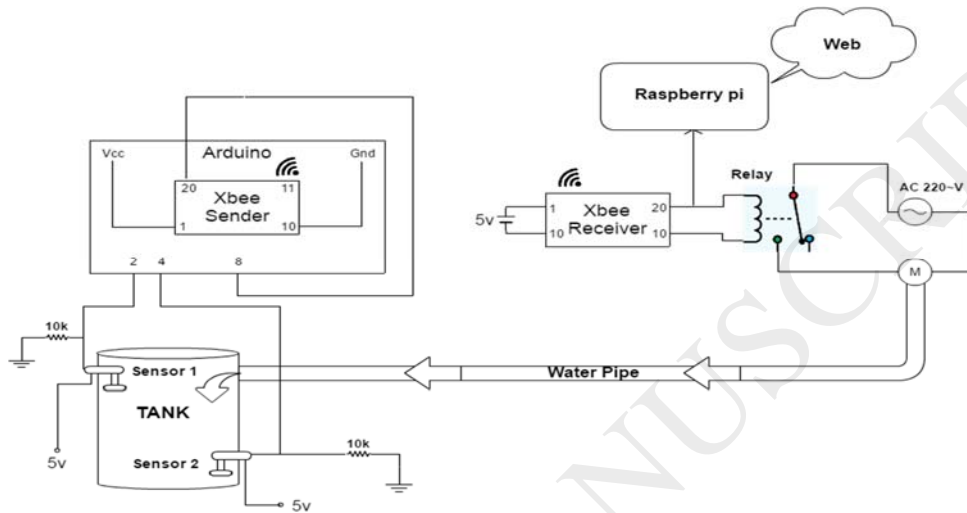

Figure 7. Web based Water Tank and Water Pump Control

interfaced with Arudino and water pump at the raspberry pi. In this circuit, we are using two water level sensors (reed switches) one of them is placed at the top of the tank and other is at the bottom,

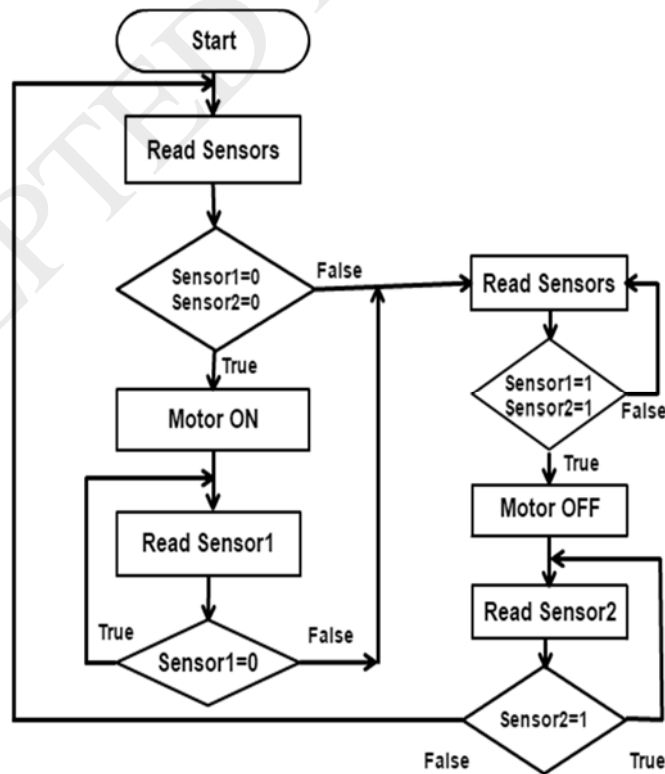

Figure 8. Flow chart of Web based Water Tank and Water Pump Control

and both the sensors are connected to the Arduino board. Arduino is programmed to check their status. When tank is empty, both the sensors give a signal to the Arduino which is transmitted through ZigBee, and received by the ZigBee interfaced with raspberry pi which activates the relay connected to turn on the motor pump. Arduino at the water tank continuously checks the status of the sensors, when the tank gets full of water, the Arduino again generates a signal to turn off the pump. Fig. 8 shows the flow chart of the water tank control. The status of the pump is updated on the user Web_App.

3.2.3 Web based Lights and Fan Control, and Exhaust Fan Control using Temperature and Humidity Sensors Data

Fig. 9 shows the circuit diagram of WoO based lights and fan control. As shown in the figure the relay is connected with raspberry pi and fan, and lights are also connected with the raspberry pi through the relay channels. The Web_APP provides interface to control the turn on and off of the lights and fan. The user Web_APP generates HTTP message using the URIs and is received by the web server and calls the specific controller designated in URI to translate HTTP message and performed specified action. The controller gets the response message and translates it back to the HTTP message in order to update the status on the Web_APP.

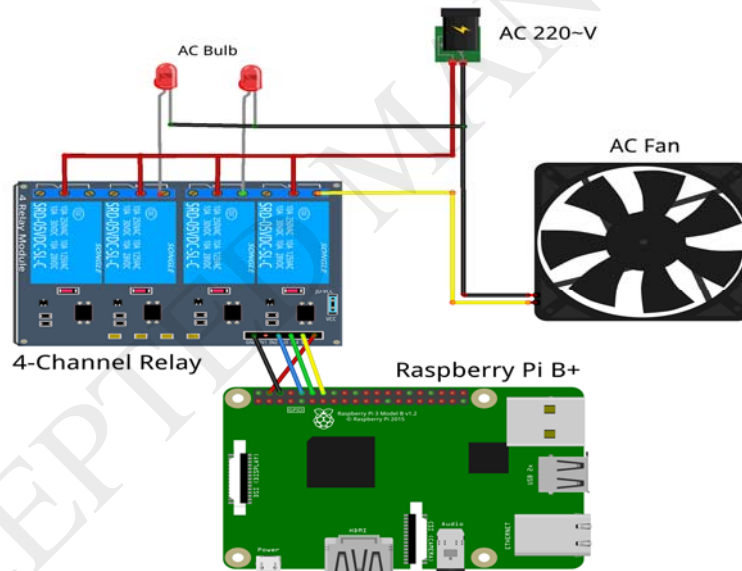

Figure 9. Circuit Diagram of WoO based lights and Fan Control

Fig. 10 shows the exhaust fan control using humidity and temperature sensor's data. The status of the temperature and humidity is updated on user Web_APP periodically using the RESTful URIs.

4. The Prototype Implementation of the Proposed Smart Home System using Web-of-Objects

The hardware implementation scenarios of various deliverables in the proposed smart home using WoO is explained in subsection 3.2. The web application is developed using Html 5.0, Python and Bottle web server platform. Various Html and JavaScript pages are generated to monitors sensors data and control each and every operation of the smart home. To provide secure access to home devices and data, we provide user registration and secure password based login.

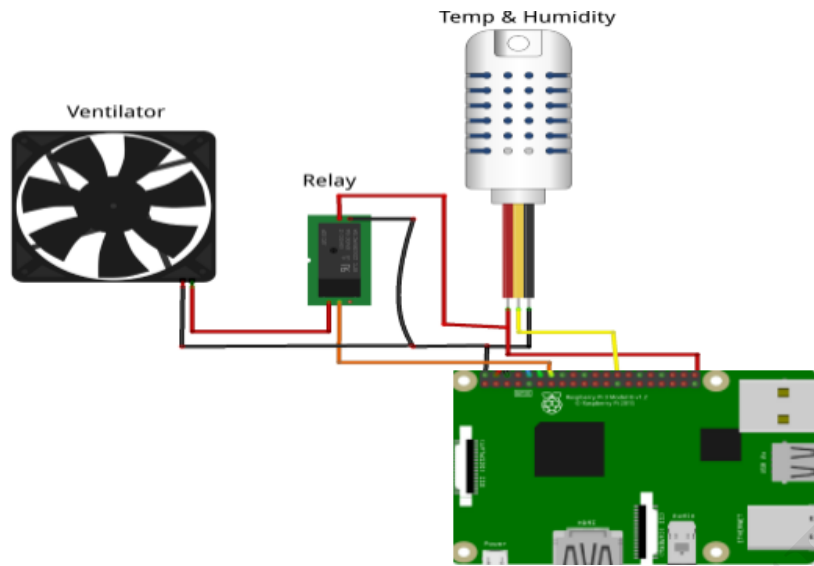

Figure 10. Circuit Diagram of WoO based Exhaust Fan Control using Humidity and Temperature Sensors

Fig. 11 (a) shows user registration procedure to the smart home. A user provides his personal details to register a home gateway and home admin user have the rights to allow a user to join the smart home. If the user is allowed then he will be automatically added to the cloud server also. Fig. 11 (b) shows the access page to login to a home gateway, and control various actuators and check sensory data.

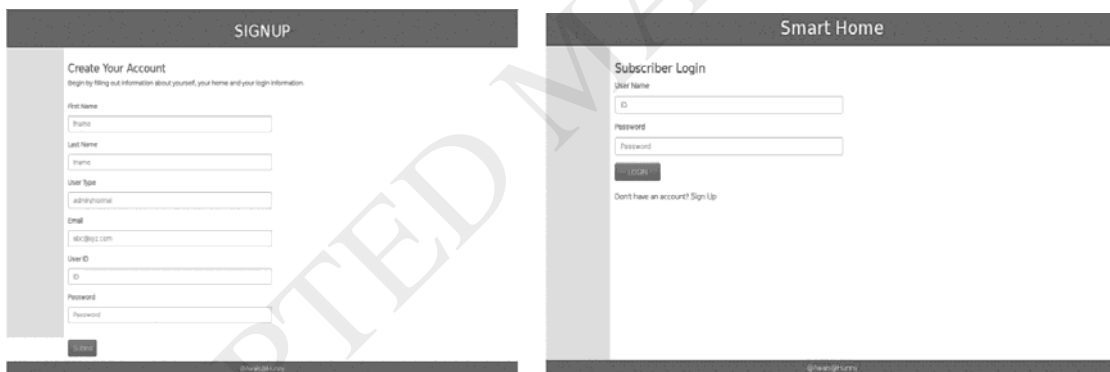

Figure 11. Smart Home Web Portal using WoO and Cloud Architecture (a). User Registration to the smart home gateway and cloud (b). Secure login to the smart home gateway

Fig. 12 shows various sensors data on the web portal after the user successful login. The page is refreshed after a specific interval by sending automatically sensor status get request by using specific URIs. Whenever the smart home gateway web server received request, it gets the sensor status and sends a response message to the client browser and also the data is stored in database in the sensors status table.

Fig. 13 shows the actuators controls and its status information. The interface provides access to the home actuating devices from anywhere and at any time. Fig. 13(a) shows initial status of the actuators and all are in the OFF state. Fig. 13(b) shows the status that light is ON. Each actuator is associated with a unique URI and using the HTTP Post method the actuators are controlled.

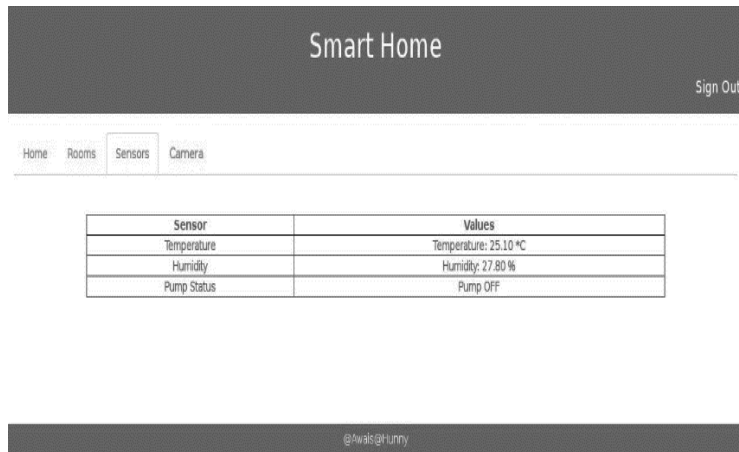

Figure 12. Sensors Current Data and Status Received from Smart Home Gateway

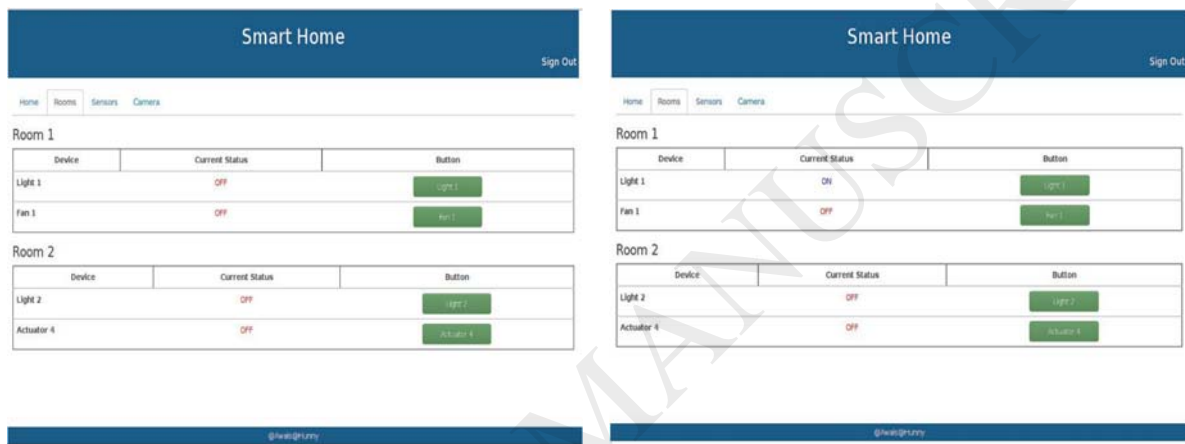

Figure 13. Smart Home Web Portal Interface for Controlling the Home (a). Initial status of Smart Home Actuators (Home Lights and Fans etc.) (b). Status of Light after Turning ON the light.

Fig. 14 shows the user presence check at the door and the user access the camera installed at the door to check the person and open the door using the web portal. When a user presence is checked at the door, it stores a series of images on the smart gateway for future security use.

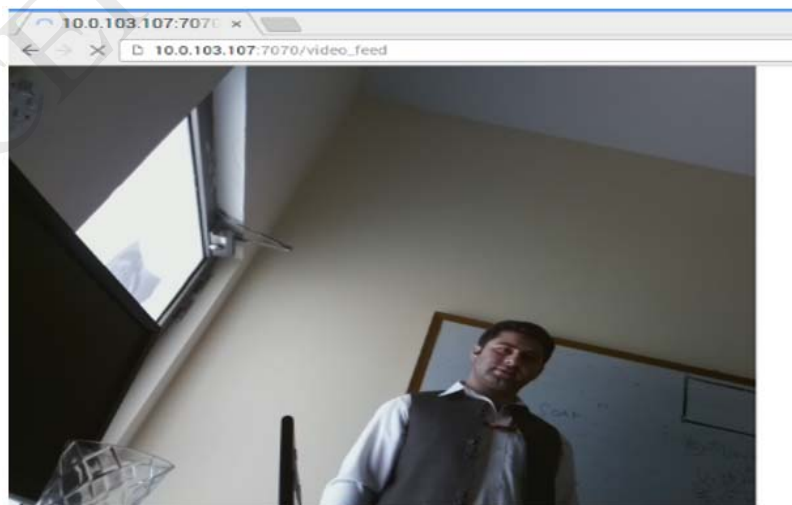

Figure 14. Camera Interface by changing the normal PI Camera as an IP Camera and used for door security control to check the person presence at the door, store the images at smart gateway for security purpose and also user can open web based open/close the door.

5. Conclusion and Future Work

In this paper, we presented an interoperable Internet-of-Things platform for smart home system using WoO and cloud. The proposed architecture provides the interoperability among the legacy devices and communication protocol, and also provides access interface for user to access home devices from anywhere. We provided RESTful based smart home system to assign a unique URI to each sensor data and actuator event to reduce the processing at webserver. It will also provide interoperability among devices. In proposed architecture, we provide the web access to home legacy devices through the smart home gateway. The gateway provides interoperability among legacy devices such as water pump and tank control, lights and fan control, and the door security control. Moreover, the gateway aggregates sensors and actuators data, and stores it on the cloud for application services and for user's history. Using the HTTP communication, the web application serving as a web client that provides user interface to check and alter the user home appliances status. This new idea is developed and tested for different functionalities of smart home services. Furthermore, the architecture can be extended to various smart building scenarios such as factories, offices, and smart grids etc.

Acknowledgments

This work was supported by National Research Foundation of Korea-Grant funded by the Korean Government (Ministry of Science, ICT and Future Planning)-NRF-2017R1A2B2012337).

References

1. Ashton, Kevin. "That 'internet of things' thing." *RFID Journal* 22, no. 7 (2009): 97-114.
2. Evans, Dave. "The internet of everything: How more relevant and valuable connections will change the world." *Cisco IBSG* (2012): 1-9.
3. Safina Showkat Ara, Zia Ush Shamszaman, and Ilyoung Chong, "Web-of-Objects Based User-Centric Semantic Service Composition Methodology in the Internet of Things," *International Journal of Distributed Sensor Networks*, vol. 2014.
4. Tai-hoon Kim, Carlos Ramos, Sabah Mohammed, Smart City and IoT, In *Future Generation Computer Systems*, Volume 76, 2017, Pages 159-162.
5. R. T. Fielding, "Architectural styles and the design of network-based software architectures", University of California, Irvine, (2000).
6. D. Romero, "RESTful integration of heterogeneous devices in pervasive environments", *Distributed Applications and Interoperable Systems*. Springer Berlin Heidelberg, (2010)
7. Hui, Terence KL, R. Simon Sherratt, and Daniel Díaz Sánchez. "Major requirements for building Smart Homes in Smart Cities based on Internet of Things technologies." *Future Generation Computer Systems* (2016).
8. Charlie Wilson, Tom Hargreaves, Richard Hauxwell-Baldwin, Benefits and risks of smart home technologies, *Energy Policy*, Volume 103, April 2017, Pages 72-83, ISSN 0301-4215
9. Pallapa, G., S. K. Das, et al. (2014). "Adaptive and context-aware privacy preservation exploiting user interactions in smart environments." *Pervasive and Mobile Computing* 12(0): 232-243.
10. Romero, Daniel, et al. "RESTful integration of heterogeneous devices in pervasive environments." *Distributed Applications and Interoperable Systems*. Springer Berlin Heidelberg, 2010.
11. Stojkoska, Biljana L. Risteska, and Kire V. Trivodaliev. "A review of Internet of Things for smart home: Challenges and solutions." *Journal of Cleaner Production* 140 (2017): 1454-1464.
12. Simon Elias Bibri, John Krogstie, Smart sustainable cities of the future: An extensive interdisciplinary literature review, *Sustainable Cities and Society*, Volume 31, 2017, Pages 183-212, ISSN 2210-6707.
13. Bandyopadhyay, Debasis, and Jaydip Sen. "Internet of things: Applications and challenges in technology and standardization." *Wireless Personal Communications* 58, no. 1 (2011): 49-69.

14. Atzori, Luigi, Antonio Iera, and Giacomo Morabito. "The internet of things: A survey." *Computer networks* 54, no. 15 (2010): 2787-2805.
15. M. A. Razzaque, M. Milojevic-Jevric, A. Palade and S. Clarke, "Middleware for Internet of Things: A Survey," in *IEEE Internet of Things Journal*, vol. 3, no. 1, pp. 70-95, Feb. 2016.
16. Shelby, Z.; Hartke, K.; Bormann, C. The Constrained Application Protocol (CoAP). Internet Engineering Task Force (IETF). June 2014
17. Jayavardhana Gubbi, Rajkumar Buyya, Slaven Marusic, Marimuthu Palaniswami, Internet of Things (IoT): A vision, architectural elements, and future directions, *Future Generation Computer Systems*, Volume 29, Issue 7, 2013, Pages 1645-1660.
18. Khan, Murad, Bhagya Nathali Silva, and Kijun Han. "A Web of Things-Based Emerging Sensor Network Architecture for Smart Control Systems." *Sensors* 17, no. 2 (2017): 332.
19. Luca Davoli, Laura Belli, Antonio Cilfone, Gianluigi Ferrari, Integration of Wi-Fi mobile nodes in a Web of Things Testbed, In *ICT Express*, Volume 2, Issue 3, 2016, Pages 96-99, ISSN 2405-9595,
20. M. R. Alam, M. B. I. Reaz, and M. A. M. Ali, "A review of smart homes—past, present, and future," *Systems, Man, and Cybernetics, Part C: Applications and Reviews*, *IEEE Transactions on*, vol. 42, no. 6, pp. 1190-1203, 2012.
21. Al-Masri, Eyhab, and Mohamed Hamdi. "RFID-Based Approach for Monitoring Patient's Health Inside Hospitals." In *New trends in networking, computing, E-learning, systems sciences, and engineering*, pp. 607-613. Springer, Cham, 2015.
22. Cook, Diane J., Michael Youngblood, Edwin O. Heierman, Karthik Gopalratnam, Sira Rao, Andrey Litvin, and Farhan Khawaja. "MavHome: An agent-based smart home." In *Pervasive Computing and Communications, 2003.(PerCom 2003)*. Proceedings of the First IEEE International Conference on, pp. 521-524. IEEE, 2003.
23. Das, Sajal K., Diane J. Cook, Amiya Battacharya, Edwin O. Heierman, and Tze-Yun Lin. "The role of prediction algorithms in the MavHome smart home architecture." *IEEE Wireless Communications* 9, no. 6 (2002): 77-84.
24. Valtchev, Dimitar, and Ivailo Frankov. "Service gateway architecture for a smart home." *IEEE Communications Magazine* 40, no. 4 (2002): 126-132.
25. Di Giorgio, Alessandro, and Laura Pimpinella. "An event driven smart home controller enabling consumer economic saving and automated demand side management." *Applied Energy* 96 (2012): 92-103.
26. Byun, Jinsung, Bounju Jeon, Junyoung Noh, Youngil Kim, and Sehyun Park. "An intelligent self-adjusting sensor for smart home services based on ZigBee communications." *IEEE Transactions on Consumer Electronics* 58, no. 3 (2012).
27. N. Lee, H. Lee, H. Lee and W. Ryu, "Smart home web of object architecture," *2015 International Conference on Information and Communication Technology Convergence (ICTC)*, Jeju, 2015, pp. 1212-1214.
28. Hafidh, Basim, Hussein Al Osman, Juan Sebastian Arteaga-Falconi, Haiwei Dong, and Abdulmotaleb El Saddik. "SITE: The Simple Internet of Things Enabler for Smart Homes." *IEEE Access* 5 (2017): 2034-2049.
29. Wu, Shaoen, Jacob Rendall, Matt Smith, Shangyue Zhu, Junhong Xu, Qing Yang, Honggang Wang, and Pinle Qin. "Survey on Prediction Algorithms in Smart Homes." *IEEE Internet of Things Journal* (2017).
30. M. R. Alam, M. B. I. Reaz and M. A. Mohd Ali, "SPEED: An Inhabitant Activity Prediction Algorithm for Smart Homes," in *IEEE Transactions on Systems, Man, and Cybernetics - Part A: Systems and Humans*, vol. 42, no. 4, pp. 985-990, July 2012.
31. L. Chen *et al.*, "Robustness, Security and Privacy in Location-Based Services for Future IoT: A Survey," in *IEEE Access*, vol. 5, no. , pp. 8956-8977, 2017.
32. Latif, Muhammad Ansar, Farman Ullah, and Sungchang Lee. "Extensible privacy framework for Web of objects based ubiquitous services." In *Information and Communication Technology Convergence (ICTC), 2015 International Conference on*, pp. 1081-1084. IEEE, 2015.
33. Xiaonan Wang, Yi Mu, Communication security and privacy support in 6LoWPAN, *Journal of Information Security and Applications*, Volume 34, 2017, Pages 108-119.
34. Majeed, Abdul, Farman Ullah, and Sungchang Lee. "Vulnerability-and Diversity-Aware Anonymization of Personally Identifiable Information for Improving User Privacy and Utility of Publishing Data." *Sensors* 17, no. 5 (2017): 1059.
35. Zur Muehlen, Michael, Jeffrey V. Nickerson, and Keith D. Swenson. "Developing web services choreography standards—the case of REST vs. SOAP." *Decision Support Systems* 40, no. 1 (2005): 9-29.

36. Liu, Yong, and Kay Connelly. "Realizing an open ubiquitous environment in a restful way." Web Services, 2008. ICWS'08. IEEE International Conference on. IEEE, 2008.
37. AlShahwan, Feda, and Klaus Moessner. "Providing soap web services and restful web services from mobile hosts." Internet and Web Applications and Services (ICIW), 2010 Fifth International Conference on. IEEE, 2010.
38. Christopoulou, Eleni, and Achilles Kameas. "GAS Ontology: an ontology for collaboration among ubiquitous computing devices." International Journal of Human-Computer Studies 62.5 (2005): 664-685.
39. B. L. Risteska Stojkoska and K. V. Trivodaliev, "A review of Internet of Things for smart home: Challenges and solutions," J. Clean. Prod., vol. 140, pp. 1454–1464, 2017.
40. S. N. Han and N. Crespi, "Semantic service provisioning for smart objects: Integrating IoT applications into the web," *Futur. Gener. Comput. Syst.*, 2017.
41. N. Zhong et al., "Research Challenges and Perspectives on Wisdom Web of Things (W2T)," in *Wisdom Web of Things*, Cham: Springer International Publishing, 2016, pp. 3–26.
42. Lin, Jie, Wei Yu, Nan Zhang, Xinyu Yang, Hanlin Zhang, and Wei Zhao. "A survey on internet of things: architecture, enabling technologies, security and privacy, and applications." *IEEE Internet of Things Journal* (2017).
43. Yichao Jin, Sedat Gormus, Parag Kulkarni, Mahesh Sooriyabandara, Content centric routing in IoT networks and its integration in RPL, *Computer Communications*, Volumes 89–90, 2016, Pages 87-104, ISSN 0140-3664, <https://doi.org/10.1016/j.comcom.2016.03.005>.
44. Manu Elappila, Suchismita Chinara, Dayal Ramakrushna Parhi, Survivable Path Routing in WSN for IoT applications, *Pervasive and Mobile Computing*, Volume 43, 2018, Pages 49-63, ISSN 1574-1192, <https://doi.org/10.1016/j.pmcj.2017.11.004>.
45. Imran, Muhammad, et al. "Provenance based data integrity checking and verification in cloud environments." *PloS one*12.5 (2017): e0177576.
46. Imran, Muhammad, et al. "Aggregated provenance and its implications in clouds." *Future Generation Computer Systems*81 (2018): 348-358.