



PERGAMON

Available online at www.sciencedirect.com



Tunnelling and Underground Space Technology 18 (2003) 145–159

**Tunnelling and
Underground Space
Technology**
incorporating Trenchless
Technology Research

www.elsevier.com/locate/tust

Present status and technology of shield tunneling method in Japan

Yukinori Koyama*

Railway Technical Research Institute, 2-8-38, Hikari-cho, Kokubunji-shi, Tokyo, Japan

Abstract

Recently in Japan, it has often been necessary to construct tunnels under more severe conditions and to develop new techniques. However, present design techniques cannot appropriately reflect the construction techniques; and thus, traditional methods are still often used. On account of the well-balanced progress between construction and design in the shield tunneling method, an innovation of the design technique is required. This paper shows an outline of the shield tunnel technique at present, behavior of shield tunnels in-site, and improvements required for design.

© 2003 Elsevier Science Ltd. All rights reserved.

Keywords: Shield tunneling; Segmental lining; Design; Earth pressure; Water pressure; Field measurement

1. Introduction

The shield tunneling construction method was adopted for the first time in urban areas of Japan for a subway project in Nagoya City during the latter half of the 1950s. Open face and hand mining methods, along with air compression pressure, were used in the shield tunneling. After that, the slurry method was developed in the earlier half of the 1970s. The earth pressure balanced method was also put into practical use in the latter half of the 1970s. It was then possible to maintain the stability of the face in an extremely soft clay ground; this had not been previously possible even when using a supplementary method. In addition, a new grouting material, which can harden immediately and maintain plasticity, was developed during the same period for backfill grouting. A new tail seal, which consists of a wire brush and special high viscose grease, was developed. Thus, the shield tunneling method was not only employed for the excavation of tunnels, but it also could control ground movements.

Recently, it has often become necessary to construct tunnels under severe conditions and to develop new techniques. However, present design techniques cannot appropriately reflect the construction techniques; and thus, traditional methods are still often used. Therefore, innovations in design techniques are needed. This paper

presents an outline of the shield tunneling technique presently used in Japan, and new design techniques.

2. Shield tunneling and related topics

2.1. Shield tunneling method in Japan

The completeness of city functions in urban areas in Japan is very important. This is because of the concentrated society functions and large populations in those areas. Therefore, the infrastructures which consist of railways, roadways, water supply systems, sewerage, electric power lines, and telecommunication networks need to be constructed underground due to the high-density utilization of urban space and in order to preserve urban landscapes and the environment. The above types of structures are concentrated under public sites, such as roads, because the space under privately-owned sites are not open to the construction of public infrastructures.

Due to various restrictions, it is difficult to choose just an ideal route with a single type of geological formation for a new tunnel. Thus, techniques are required which can be applied to different types of grounds. Due to the growth of economic activities in Japanese society, the expansion of the capacity of infrastructures and solutions to problems related to the complicated utilization of underground space have become necessary.

Under the above-mentioned circumstances, a breakthrough to counteract some topics related to the shield

*Tel.: +81-42-573-7230; fax: +81-42-573-7209.

E-mail address: koyama@rtri.or.jp (Y. Koyama).

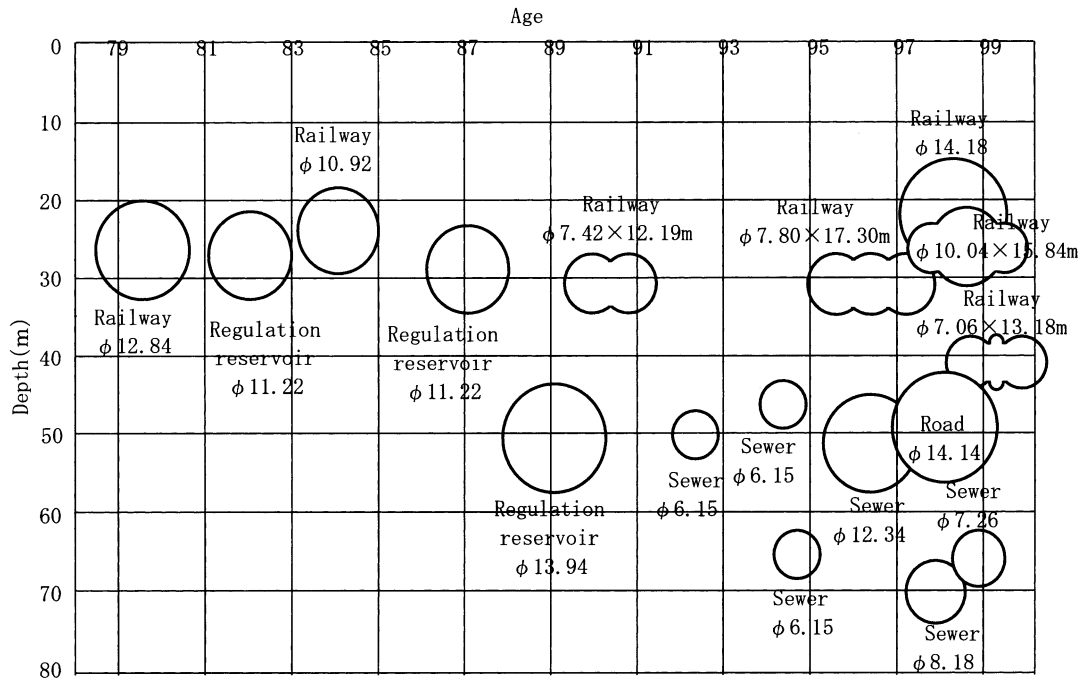

Fig. 1. Sequence of a large face excavation and a large overburden excavation.

tunneling method in Japan are needed, and many new techniques have been developed. The main technical topics are as follows:

1. long distance excavation;
2. large overburden excavation;
3. large face excavation;
4. automatic excavation;
5. special cross-section shield;
6. expansion and reduction of shield;
7. branching and confluent; and
8. construction with a sharp curve.

2.2. Present status of the shield tunneling method in Japan

In order to understand the progress of the shield tunneling technique, it is useful to grasp the degree of accomplishment for the topics. Figs. 1 and 2 present overviews of the tunnel diameter, the water pressure, the depth and the curve radius. The maximum earth pressure that has been achieved for the shield tunnel is 0.9 MPa. The smallest curve radius of the tunnel is 20 m, under high water pressure.

Fig. 1 shows that the construction of special-shaped tunnels, in which all cross-sections are excavated at the same time with a closed-type shield machine, has been increasing.

Moreover, as discussed below, special-shaped shields have been developed. It is possible to excavate a specific shape simultaneously for the entire cross-section by means of these type shields.

2.2.1. Multi-circular face shield method (MF shield)

The MF shield, utilizing the advantages of the slurry type shield, was developed to construct flat-shaped tunnels. To avoid the interference between cutter faces when they rotate, they are set at different positions in the longitudinal direction (Fig. 3).

A double-circular face type was developed first. Then, triple-circular face type shields have been developed to construct train stations in complicated underground spaces. In addition to the above, a four-circular-face type was developed to construct subway stations, whose shape is more complicated than that of triple-circular face type tunnels.

2.2.2. Double O-tube shield (DOT shield)

The DOT shield is an earth pressure balanced type shield with the same purpose as the MF shield. Two spoke cutter wheels of the shield rotate in the opposite directions on the same plane, and so as not to come in contact, the rotation control is done separately.

2.2.3. Developing parallel link excavation shield (DPLEX Shield)

The DPLEX shield is quite a new method, which is modified to a large extent from the conventional earth pressure balanced type shield.

The shield employs multiple rotating shafts to which cranks are fit at the right angle (Fig. 4). A cutter frame equipped with a number of rotating shafts turn, the cutter frame starts a parallel link motion, which makes

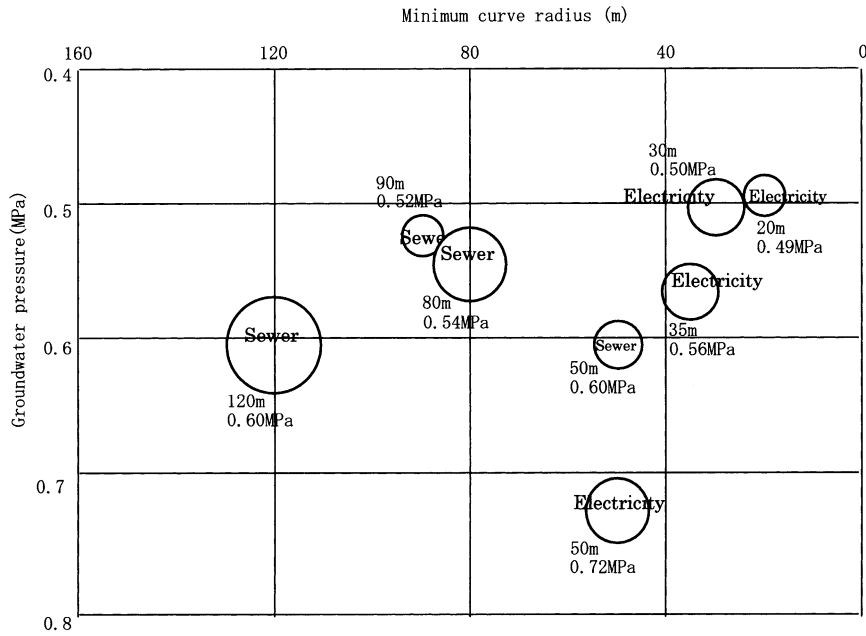

Fig. 2. Achievements of a sharp curve execution under high water pressure.

it possible to cut a tunnel with a cross-section analogous to the shape formed by the cutter bits.

The advantages of this shield are not only a reduction of cutter torque due to short shafts, but also the applicability of unusual shapes.

3. Present status and topics related to shield tunnel linings

3.1. Conventional segmental lining

The segments of tunnel linings in Japan are usually made of reinforced concrete (RC), steel, cast iron, or a composite structure of steel and concrete. RC is the most popular material, followed by steel, and then cast iron. Bolts are used at the main joints of those segments.

As for RC segments, box segments, which are jointed with long bolts, were used in early times (Fig. 5). However, plane type segments have been used recently in order to reduce the deficient area (Fig. 6). If partic-

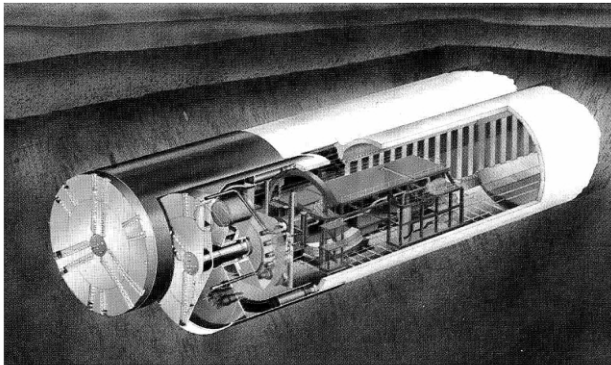

Double-circular face type. (Matsumoto, Y., 1994A)

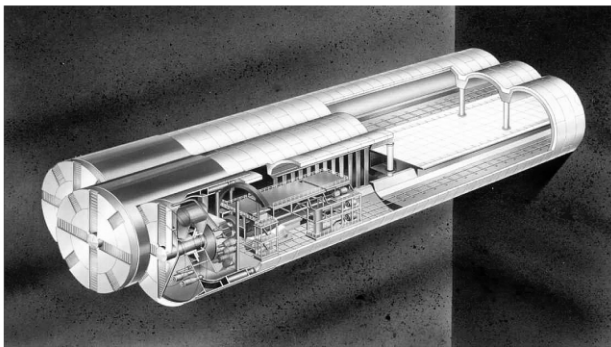

Triple-circular face type. (Matsumoto, Y., 1994B)

Fig. 3. Multi-circular face shield (Matsumoto, 1994a,b).

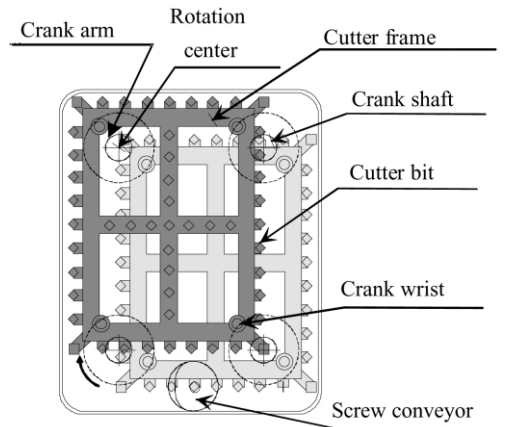

Fig. 4. Principle of excavation by the DPLEX (Kashima and Kondo, 1997).

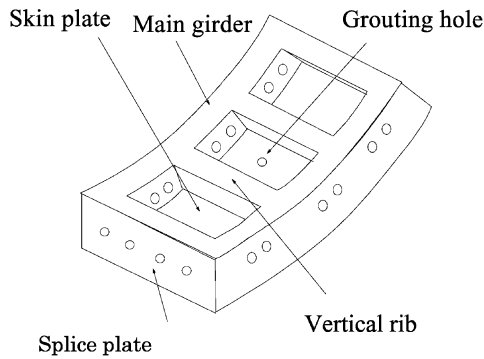

Fig. 5. RC box segment.

ularly strong rigidity is required for a metal fitting, the small box is made from cast iron (Fig. 7).

As for steel segments, segments have been used in which steel plates are built in a box shape by welding and are jointed with short bolts (Sakai and Tazaki, in press). As for cast iron segments, segments which are box- or corrugation-shaped and are jointed with short bolts, have been used.

3.2. Tendency and subject for development of segmental lining

3.2.1. New segmental lining

The size of shield tunnels is presently growing larger. Thus, the diameter of the joint bolts has become larger as well as the tool for bolting. Under these conditions, an automatic erection of segments is required for a safe working environment and in order to maintain the good quality of the erection. However, the equipment for the erection has had a tendency to be complex and the time it takes for the erection has a tendency to be long. This is because a segment with bolt joints is disadvantageous to an automatic erection. An innovation in segment joints is needed, because the cost to produce segments makes up a high percentage of the total construction cost of a shield tunnel. In particular, the cost of joint metal is expensive. Under such conditions, many types

of segment joints have recently been developed and adopted in various sites.

3.2.2. Tendency and subject of segmental lining

The width of segments has increased recently for the purpose of reducing joints, which are weak points for strength, and shortening the total erection time. In such cases, it is necessary to study not only the feasibility of the erection, but also the phenomenon of the axial direction of tunnels. For example, the effects of the mutual erection of segments and stress distribution on segments in an axial direction need to be investigated.

A minimum thickness for the segments has been decided according to the bearing capacity to earth pressure and water pressure and by the proportion to the outer diameter of the tunnel, which is obtained by an analysis of the damage records. However, segments recently tend to be thinner not based on the above-mentioned design method, because construction techniques have been progressing. A design method which is suitable for such recent trends, is necessary.

4. Present status of design method for shield tunnels

4.1. General remarks

In designing segments, the stress in each part of a segment is usually calculated with a design model, by taking account of the structural property of segmental lining and interaction between the ground and lining, so that the stress does not exceed the allowable limit. Hence, to design a segment, we need to reasonably model the segment structure and assume its interaction with the ground. There are a number of design models proposed so far (ITA, 2000).

4.2. Structural model

The structural models for the segment ring are shown in Fig. 8. The segments are assembled in a staggered pattern to compensate for the decrease in the bending

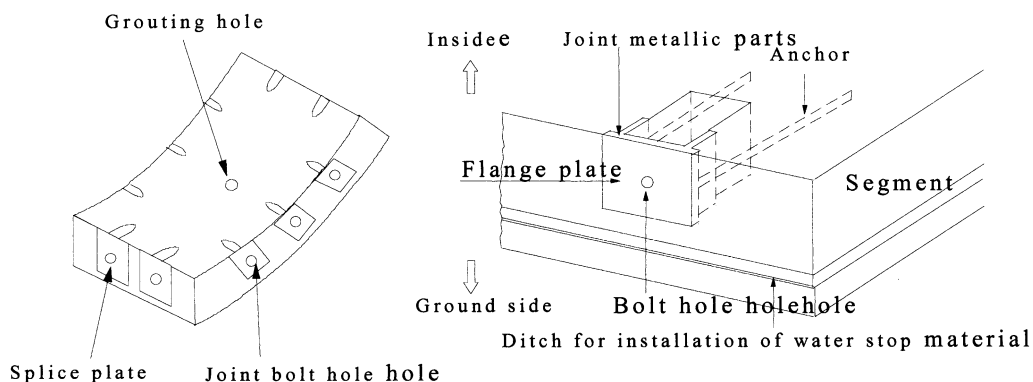

Fig. 6. Metallic parts type of RC plane segment.

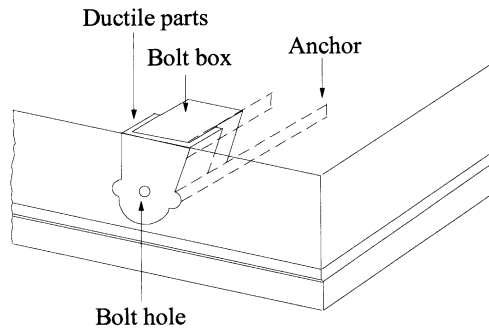

Fig. 7. Ductile parts joint type of RC plane segment.

rigidity of the circumferential joint. The multi-hinge ring model is not applied.

Up to this time, the uniform rigidity ring model has been applied. As the circumferential joint is assumed to have the same rigidity as that of the segment, the moment for the design of joint is overestimated and that occurring at the segment is not calculated correctly. Therefore, it is difficult to design the bending moment at the joint area.

An average uniform rigidity ring model was proposed in order to make up for the faults of the uniform rigidity ring model. In this model, the deformation of a ring with joints is compared to that without any joints. The ratio between the rigidity of the former and the one of the latter is assumed to be η , where η is the effective ratio of the bending rigidity (Fig. 9). In addition, a bending moment whose magnitude is additional rate ζ times that of the segment is considered to be distributed to the neighbor segment in the joint area (Fig. 10). At this point, the values of the bending moments used for the segment and the joint are assumed to be $M_0 (1 + \zeta)$ and $M_0 (1 - \zeta)$, respectively. Even in this model, the effective ratio of the bending rigidity (η) is described as being universally determined by the profile of the joint and the shape and the size of the segment. However, the rigidity of the circumferential joint, in

terms of the same rigidity as that of the segment, if all joint surfaces are compressed, varies with the stress load conditions. Therefore, it is natural that η changes depending on the load. However, although the distribution of bending moment near the circumferential joints is taken into consideration, using the additional rate (ζ), the bending moment significantly varies with the bending rigidity of the circumferential joint. Then, such a condition physically has no basis, as shown in Fig. 10, where the moment between the two rings is simply distributed along the joint area. It is then impossible to calculate actual distribution of the bending moment by using this model.

For this reason, the beam spring model is applied nowadays. Segments are modeled with beams in this model. The circumferential joints are modeled by the rotation of springs and their rigidities are expressed by the constants of the springs concerning the bending moments. With regard to the longitudinal joint, in the beam spring model I, it is assumed that the displacement of the ring beam is equal to that of the neighboring ring beam at the joint, where there is no gap caused by the shear stress. The relative displacement also occurs between the two neighboring rings in the longitudinal direction, and is concentrated at the centerline of the segment rings. Therefore, the beam spring model II, in which this displacement is expressed by means of the shear spring, is also applied. The linear, bilinear and trilinear models in Fig. 11 are considered concerning the characteristics of the rotation spring, and they are determined by an analysis or through experiments. To calculate the constant of the rotation spring of the RC flat plate segment by an analysis (Fig. 12), equations are proposed.

4.3. Interaction model for simple circular tunnels

There are a number of tangible interaction models, which can be categorized into two types. One is a method using finite element analysis and the other is a

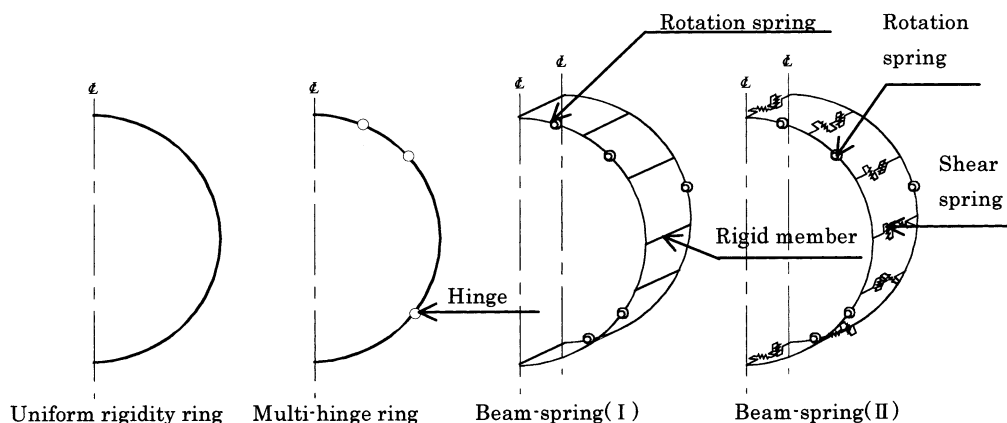

Fig. 8. Structural models of the segment ring (Koyama, 2000a).

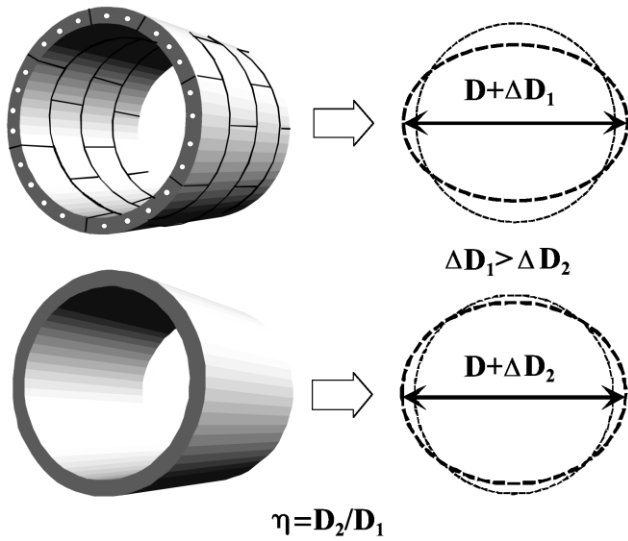

Fig. 9. Concept of the efficient ratio of bending rigidity.

method using beam elements representing tunnel lining, which carries the earth pressure, water pressure and dead weight. While the former is not widely applied, different models have been proposed so far for the latter.

These models are developed for the open type shield for manual excavation. The models can be sub-categorized into the following three types.

1. The tunnel is assumed to be made of a rigid material and the soil reaction is determined to be independent of the tunnel deformation caused by active loads.
2. The soil reaction is determined in consideration of the tunnel deformation caused by active loads.

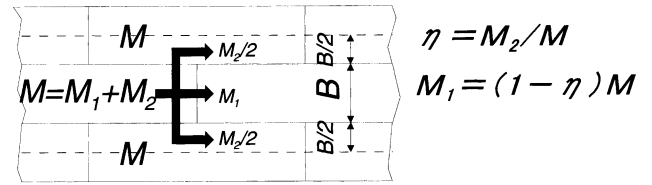

Fig. 10. Concept of the additional rate of bending rigidity.

3. In addition to the condition in (2), the shape is simplified.

Among Japanese tunnel engineers, for shield tunnel designing, the above (1) is called the ‘conventional model’ (Fig. 13), and (2) is called the ‘full-circumferential spring model’ (Fig. 14). This section discusses the latter.

There are two modeling methods for the earth and pore water pressures. In the first one, the modeling does not separate the two pressures, but in the second one, the modeling is separated into the two parts. In general, the former is applied to the ground of low permeability such as clayey soil, and the other is applied to the ground of high permeability such as sandy soil. The earth pressure is divided into two parts, vertical and horizontal pressures.

4.3.1. Vertical earth pressure

There are two cases in assuming the vertical earth pressure acting on the upper part of segmental ring, one assumed to be a full overburden and the other a reduced one to take into account the soil shear strength. For both pressures, a uniform load is assumed. The latter is

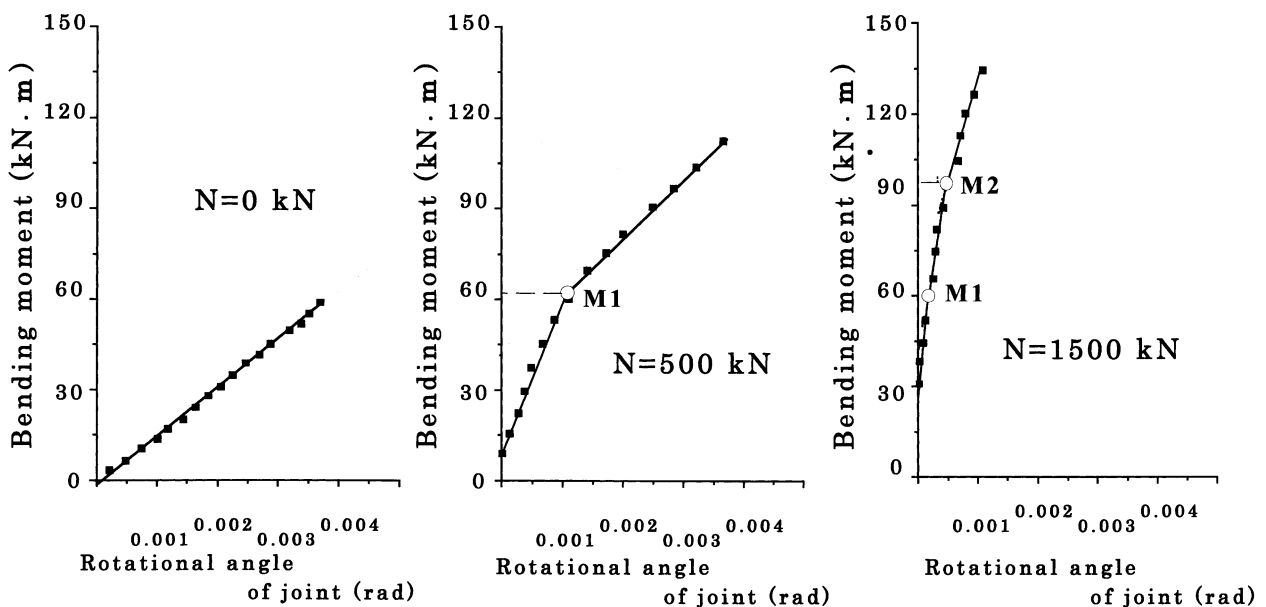

Fig. 11. Modeling of the rotational spring constant (Koyama, 2000b).

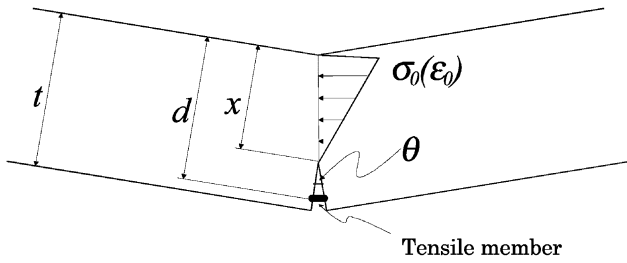

Fig. 12. Balance of force at joint area (Koyama, 2000c).

calculated by Terzaghi's formula. The upward earth pressure from the tunnel bottom is assumed to be the same as downward earth pressure in the upper part in magnitude and distribution.

4.3.2. Horizontal earth pressure

The horizontal earth pressure is assumed to be a uniformly varying load that increases with increasing depth. Hence, the horizontal earth pressure at the top of the ring is derived from the vertical earth pressure multiplied by the coefficient of horizontal earth pressure

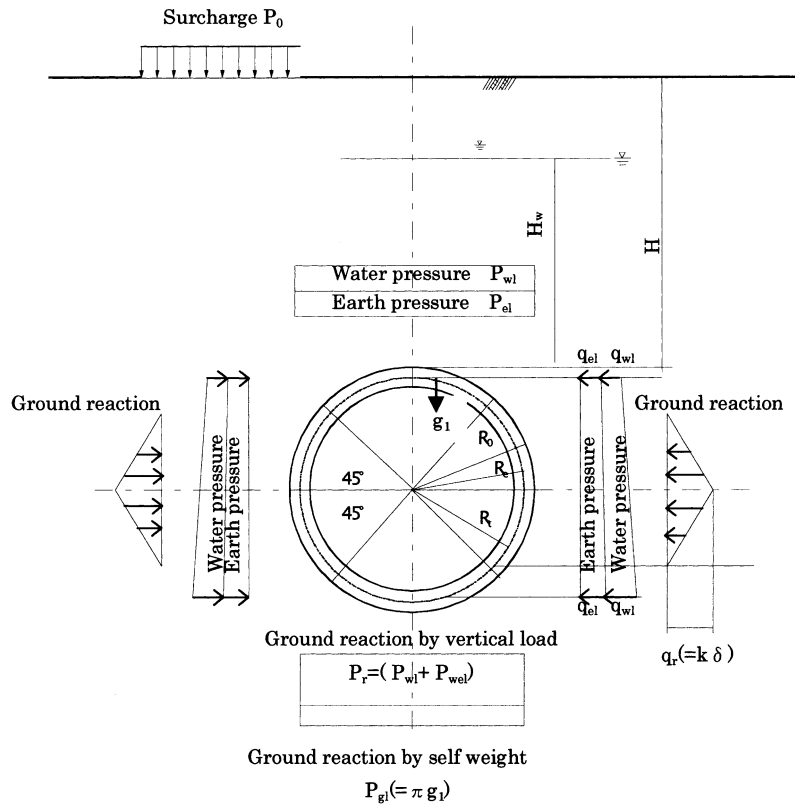

Fig. 13. Loads in the conventional model (JSCE, 2001).

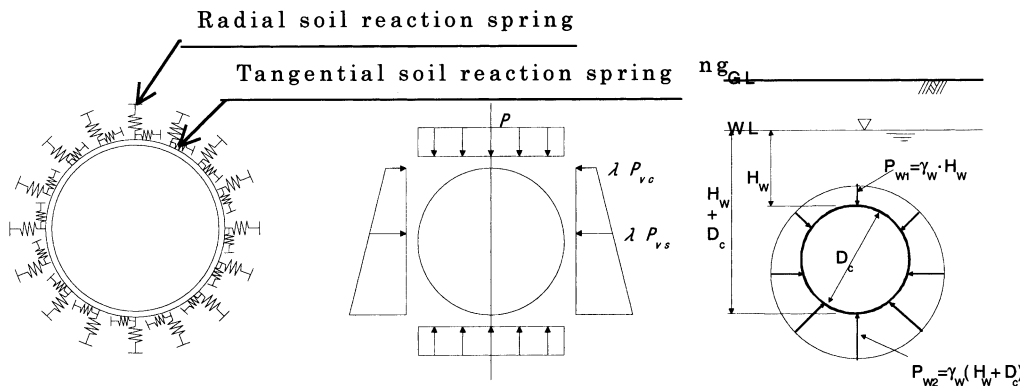

Fig. 14. Full-circumferential spring model (RTRI, 1997).

Table 1
Coefficient (λ) of lateral earth pressure in full-circumferential spring model (RTRI, 1997)

Type of soil		λ	N value guideline
Soil-water separated	Sandy soil	Very dense	0.45
		Dense	0.45–0.50
		Medium, loose	0.50–0.60
Soil-water integrated	Clayey soil	Hard	0.40–0.50
		Medium, stiff	0.50–0.60
		Soft	0.60–0.70
		Very soft	0.70–0.80

(Table 1). The vertical earth pressure increases with the depth of ground, but it should slightly be mitigated by the contribution of ground shear strength.

4.3.3. Soil reaction

The soil reaction is assumed to have a value that corresponds to tunnel deformation and displacement and modeled as ground springs located along the whole periphery of the tunnel. Table 2 shows the coefficient of soil reaction.

4.3.4. Water pressure

The water pressure on the tunnel is assumed to act in the direction to the center of the ring, which increases in direction of depth from the ground water level.

5. Actual conditions of earth pressure and water pressure affecting shield tunnels

5.1. Present status of design method for shield tunnels

Among a number of shield tunnels constructed so far, there are practically few cases where the loads affecting segments and occurring strain are measured at closed type shield tunnels. Generally speaking, the earth pressure is measured by means of earth pressure meters placed behind the segments. The pressure measured in this way includes both the effective earth pressure and

water pressure. In following sections, the pressure measured by means of earth pressure meters is called the earth pressure or the total earth pressure. However, there are a number of cases where the water pressure is measured by means of the measurement of ground water flowing into bored holes. The bored holes are constructed from grouting holes in segments through the hardened grouting material after the segmental lining is exposed to ground and structurally stabilized.

This chapter focuses on the examples of the measurement of earth pressure and water pressure, and describes the earth pressure and water pressure in connection with design methods, regarding them as expressing some characteristics of the loads that are actually affecting the tunnels.

5.2. Long-term loads affecting simple circular shield tunnels

5.2.1. Measurement results in clayey layers

This section shows the cases of earth pressure and water pressure measurement at tunnels in clayey alluvium and clayey diluvium. These two tunnels are constructed by using slurry shields. The external diameter and overburden of one tunnel are 3.95 m and 22 m, respectively, and those of the other tunnel are 4.95 m and 13 m.

Figs. 15 and 16 show the distribution of earth pressure in the circumferential direction and changes in the ratio of effective earth pressure to total earth pressure in alluvium as time passes, respectively. In the same way, those in diluvium are shown in Figs. 17 and 18.

At both tunnels, the earth pressure gradually changes for a long period. This is thought to result from the changes in atmospheric temperature (Ariizumi et al., 1998).

From these measurement results, the following can be described for the earth pressure and water pressure having affect over a long period.

1. The effective earth pressure is never equal to zero at the tunnel in clayey alluvia although it is small.

Table 2
Coefficient (k) of ground reaction \times tunnel diameter (D) in full-circumferential spring model (RTRI, 1997)

Type of soil		During grouted material hardening (N/mm ²)	After grouted material hardening (N/mm ²)	N value guideline
Sandy soil	Very dense	35.0–47.0	55.0–90.0	$30 \leq N$
	Dense	21.5–35.0	28.0–55.0	$15 \leq N < 30$
	Medium, loose	–21.5	–28.0	$N < 15$
Clayey soil	Hard	31.5–	46.0–	$25 \leq N$
	Medium	13.0–31.5	15.0–46.0	$8 \leq N < 25$
	Stiff	7.0–13.0	7.5–15.0	$4 \leq N < 8$
	Soft	3.5–7.0	3.8–7.5	$2 \leq N < 4$
	Very soft	–3.5	–3.8	$N < 2$

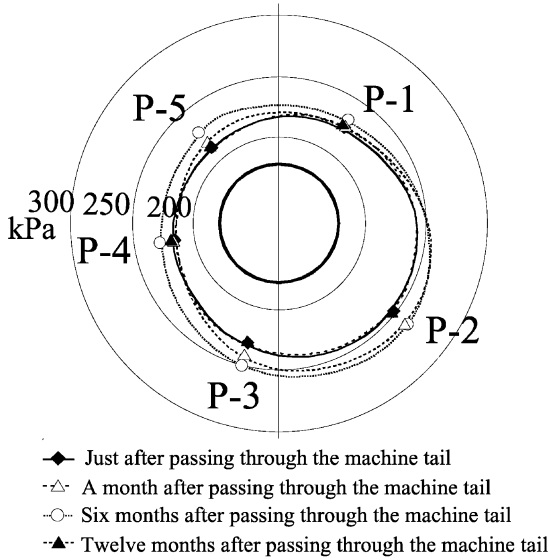

Fig. 15. Distribution of earth pressure into the circumferential direction (in an alluvium) (Ariizumi et al., 1998).

2. The effective earth pressure is almost equal to zero at the tunnel in clayey diluvium.
3. The distribution of total earth pressure is extremely asymmetric at the tunnel in alluvium where small effective earth pressure acts.
4. Relatively uniform earth pressure acts on the tunnel in diluvium although the effective earth pressure is small.

5.2.2. Measurement results in sandy layers

This section shows the cases of earth pressure and water pressure measurement at tunnels in a sandy alluvium and sandy diluvium. These two tunnels are constructed by using slurry shields. The external diameter and overburden of one tunnel are 5.10 m and 17 m, respectively, and those of the other tunnel are 9.80 m and 19 m.

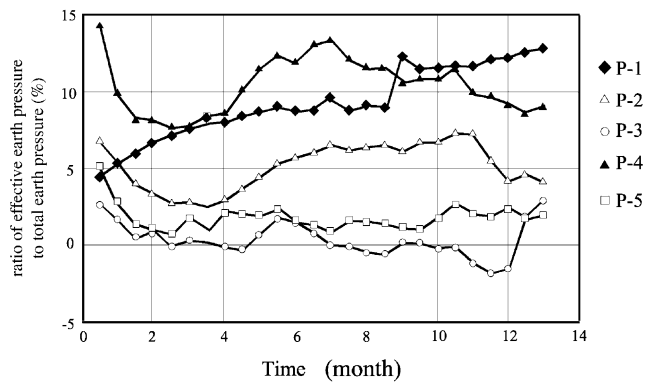

Fig. 16. Changes in the ratio of effective earth pressure to total earth pressure over time (in an alluvium) (Ariizumi et al., 1998).

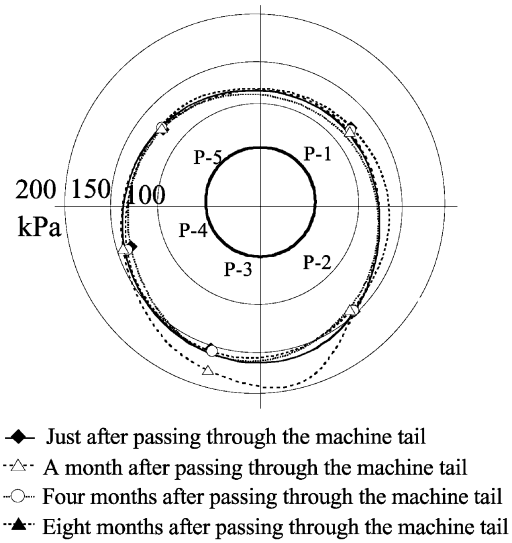

Fig. 17. Distribution of earth pressure into the circumferential direction (in a diluvium) (Ariizumi et al., 1998).

Fig. 19 shows the distribution of earth pressure and water pressure in the circumferential direction in alluvium. In the same way, that in diluvium is shown in Fig. 20.

From these measurement results, the following can be described concerning the earth pressure and water pressure acting on the tunnels for a long period.

1. The effective earth pressure is small at the tunnel in sandy alluvium.
2. The water pressure is dominant and the effective earth pressure is equal to zero in sandy diluvium.
3. The distribution of the total earth pressure is nearly symmetric.

5.2.3. Measurement results in gravel bed

This section discusses the cases of the measurement of one tunnel in gravel alluvium and two tunnels in gravel diluvium. These three tunnels are constructed by

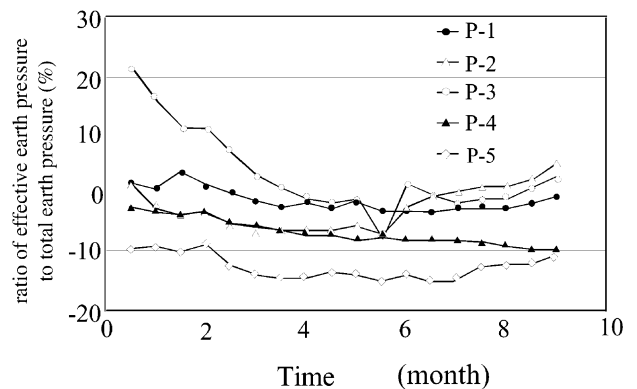

Fig. 18. Changes in the ratio of effective earth pressure to total earth pressure over time (in a diluvium) (Ariizumi et al., 1998).

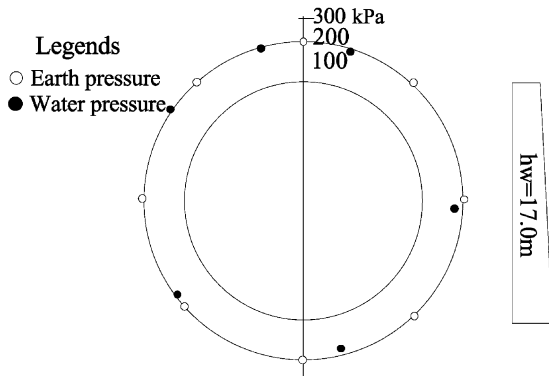

Fig. 19. Distribution of earth pressure into the circumferential direction (in an alluvium) (Itoh and Saito, 1991).

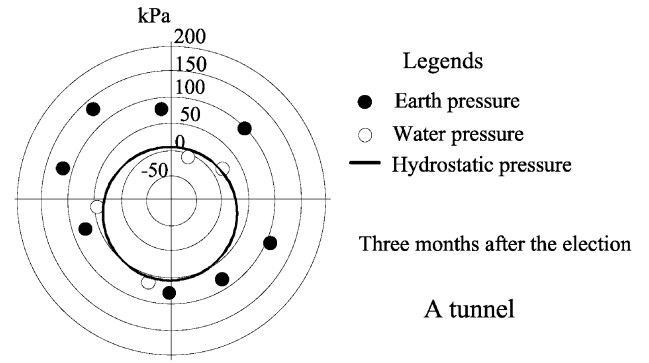

Fig. 22. Distribution of earth pressure into the circumferential direction (in a diluvium) (Fujii et al., 2000).

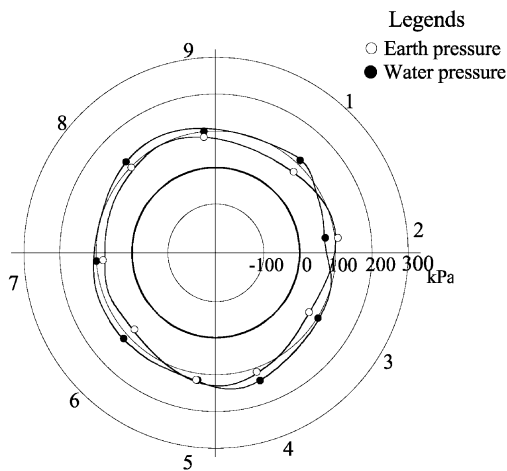

Fig. 20. Distribution of earth pressure into the circumferential direction (in a diluvium) (Koyama et al., 1995).

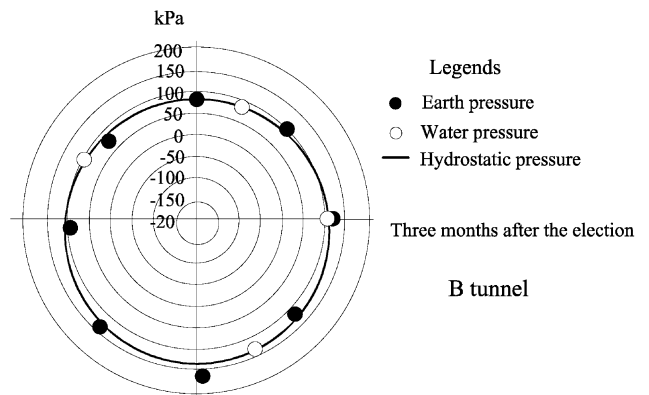

Fig. 23. Distribution of earth pressure into the circumferential direction (in a diluvium) (Fujii et al., 2000).

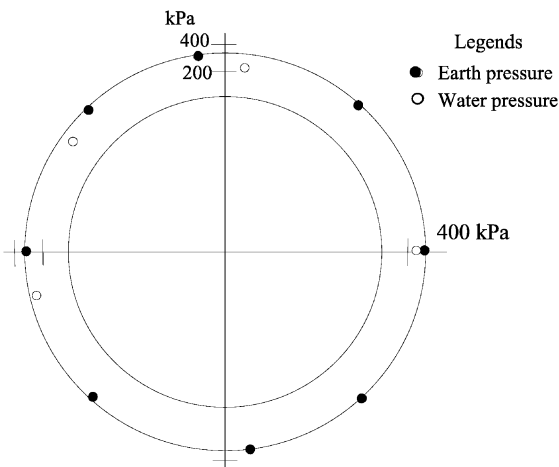

Fig. 21. Distribution of earth pressure into the circumferential direction (in an alluvium) (Koyama, 2000d).

means of slurry shields. The external diameters of these tunnels are 3.35 m, 6.2 m and 4.75 m, and overburdens are 25 m, 10 m and 12 m, respectively.

The distribution of earth pressure and water pressure in the circumferential direction in alluvium is shown in Fig. 21, and that in diluvium is shown in Figs. 22 and 23.

From these measurement results, the following can be described concerning the earth pressure and water pressure acting on the tunnels for a long period.

1. The effective earth pressure is approximately 30% of the total earth pressure at the tunnel in gravel alluvium although the water pressure is dominant.
2. In the case where the ground water level is high at the tunnel in gravel diluvium, only the water pressure acts on the tunnel and the effective earth pressure is nearly equal to zero.
3. If the ground water level is low at the tunnel in gravel diluvia, large effective earth pressure acts on the upper part of the tunnel. However, the effective earth pressure acting on the lower part of the tunnel is small.

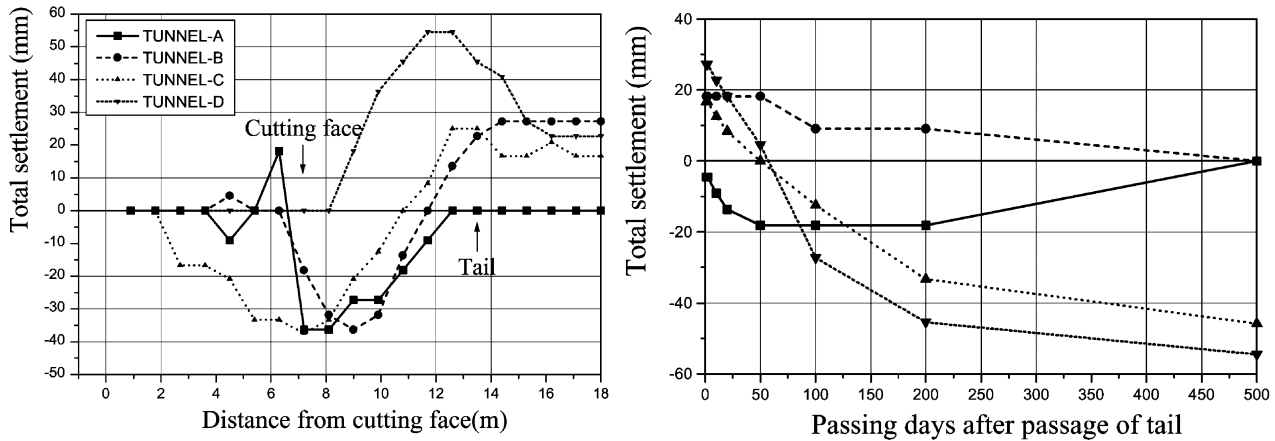

Fig. 24. Underground vertical displacement [just above the shield (0.5 m)] (after Hirata, 1989).

4. In case the effective earth pressure is small, the distribution of the total earth pressure is uniform. However, if the effective earth pressure is dominant, the distribution of the total earth pressure is uneven to some extent.

5.3. Factors influencing loads acting on tunnels

5.3.1. Relationship between ground displacement and earth pressure

The earth pressure acting on a tunnel for a long period is considered to depend on the strain of soil near the surface of tunnel. Actual strain conditions of soil near the tunnels are estimated from ground displacement near the tunnel in this section. Fig. 24 shows the measurement results during the construction of subway shield tunnels in Osaka. In all cases, the values of measurement vary widely although the ground conditions are similar (in clayey alluvia). The results of measurement generally show a tendency of settlement, but there are some cases where they show a tendency of rise. This suggests that the strain of soil just above the tunnel can either extend or shrink and that the earth pressure acting on the tunnel crown can also either increase or decrease when compared with the situation before the excavation of the tunnel.

There are no examples of detailed measurement around tunnels. The strain of ground near the tunnel can be considered to vary widely, depending on the operational control of shield, the way of backfill grouting and other conditions. It is speculated that the scattered strain would cause the heterogeneity of distribution of earth pressure affecting tunnels.

5.3.2. Influence of backfill grouting

The influence of backfill grouting on shield tunnels has been confirmed by laboratory and other tests, but an interesting test has been carried out to confirm it by using an actual shield tunnel. The test was carried out at an earth pressure balanced shield tunnel whose external diameter is 5.30 m. The test was carried out in two cases (Table 3).

The backfill grout was injected with usual method in one case, and in another case, the grouting pressure was lower and the volume was smaller. The earth pressure and water pressure affecting the tunnel are measured in the test. The tests were carried out at two sections of the tunnel in the clayey diluvia and sandy diluvia to grasp the influence of soil condition. These results are shown in Fig. 25 and Fig. 26.

The following was obtained from these results.

Table 3
Design of backfill grouting (Nishizawa et al., 1996)

	Case1	Case2
Design grouting pressure	150 kPa	50 kPa
Design grout ratio	139%	100%
Backfilling material	Standard mixture	Lean mixture
Grouting method	Usual method	Stop grouting when grouting pressure becomes bigger than design pressure

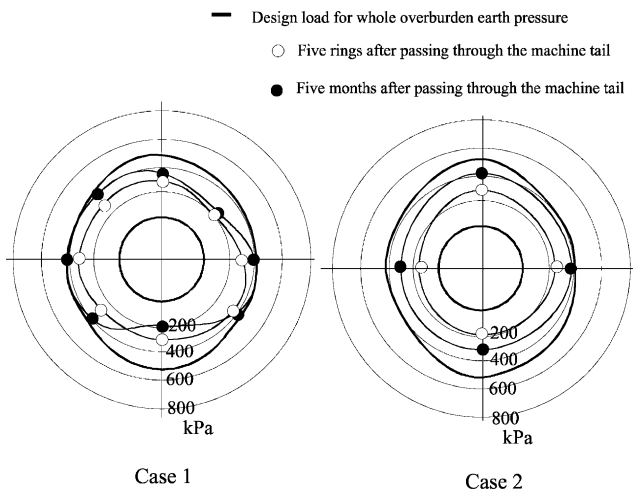

Fig. 25. Distribution of earth pressure into the circumferential direction in the clayey diluvium (Nishizawa et al., 1995).

1. If the backfill grouting pressure is low, the earth pressure is small and its distribution is uniform in all ground conditions.
2. If the backfill grouting pressure is high, the earth pressure is high and its distribution is uneven in all ground conditions.

In the actual excavation of shield tunnel, the backfill grouting is expected to fill up the gaps between the segments and ground and to stabilize the tunnel. At the same time, the backfill grouting gives a measure to add high pressure to the surface of opening in order to reduce the settlement of ground. As the segments receive the soil reaction caused by the backfill grouting, the segments are considered to receive larger loads than those considered at design. Consequently, in case the backfill grouting is carried out at high pressure and causes local destruction of ground around the tunnel, the final distribution of earth pressure is assumed to be uneven. This is indicated from the laboratory tests of backfill grouting (Koyama, 2000e).

5.3.3. Influence of operational control

Fig. 27 shows the results of measurement of variations of diameters of the same tunnel in the horizontal and vertical direction. Although the ground condition is almost uniform, there are some sections where deformation modes vary from major axis in horizontal to major axis in vertical. It is impossible to explain the differences of deformation modes by using a model where the earth pressure and water pressure act on the tunnel. It is understood that the modes with the shorter side at the top occur at curved line sections by comparing this deformation data with excavation data. It is reasonable to think that these modes result from the conflict between the segmental rings and shield tails. That is to say, the operational control remarkably influ-

ences the loads acting on tunnels and subsequent deformation.

5.3.4. Influence of impermanent loads in excavation

The earth pressure and water pressure are mainly discussed above. The loads acting on the segments become the maximum when the shield machine is driven. Fig. 28 shows the examples of the measurement by using the earth pressure cells installed on the segments to grasp the influence of tail brushes on the segments. This result shows that the pressure becomes the maximum during passage through shield brushes and two times as large as that into the ground. However, this pressure does not remain and only momentarily affects the segments.

Fig. 29 shows the result of measurement of the pressure acting on the segment when the shield is driven along a sharp curve. From the result of measurement, high partial pressure is known to act on the segments as the shield is driven. However, the pressure is known to be impermanent and disappears as the shield stops. A part of the partial pressure remains in the tunnel and controls the condition of tunnel deformation as mentioned above.

The impermanent pressure acting on the segments as mentioned above does not affect stability of the tunnels for a long period directly. However, the impermanent pressure causes cracks and spalling of segments and a leakage of water, and then the quality of segments, consequently, becomes low.

6. Issues for segment design and R&D trends

For the designing of segments, the following two hypotheses should hold when we adopt a design methodology based on the above-mentioned long-term earth pressure and water pressure.

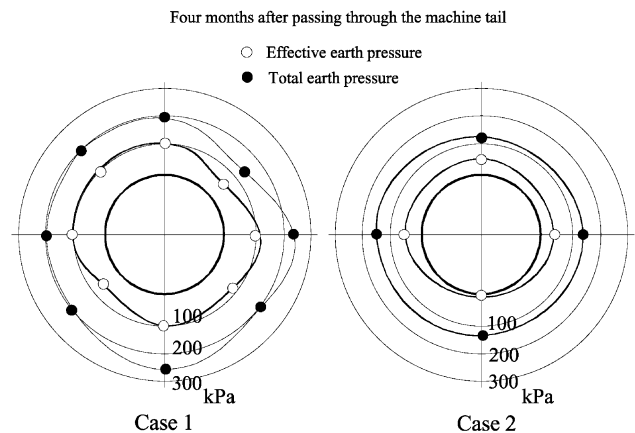

Fig. 26. Distribution of earth pressure into the circumferential direction in the sandy diluvium (Nishizawa et al., 1996).

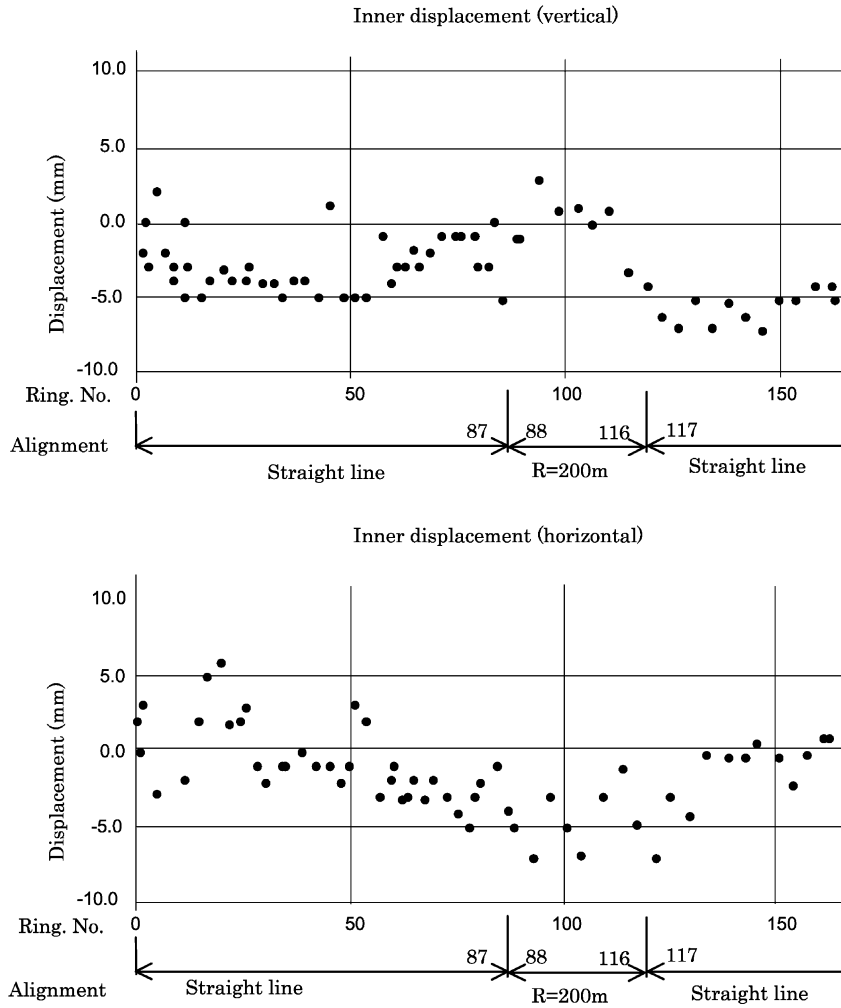

Fig. 27. Inner displacement of segment (example of measurement) (TEPCO, 1998).

1. Tunnel deformation calculated in designing a tunnel, is subject to the earth pressure (including the soil reaction) and water pressure acting on the tunnel.
2. Tunnel deformation before the tunnel reaches the long-term stable condition is smaller than that under the stable condition.

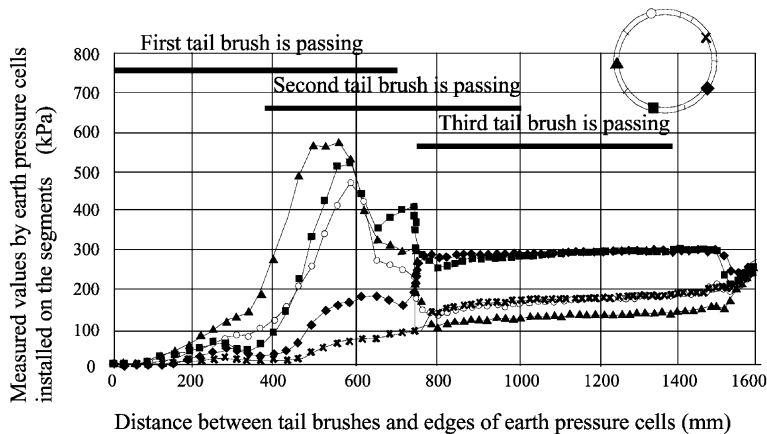

Fig. 28. Influence of tail brushes on the segments (Ariizumi et al., 1999).

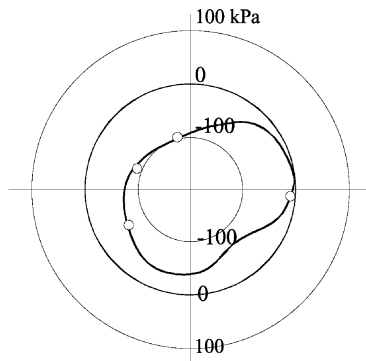

Fig. 29. Result of measurement of the pressure acting on the segment (in a sharp curve) (Okada et al., 1996).

As shown in the former section, however, the above two points do not necessarily hold in actuality. The following are conceivable causes why these do not hold.

1. Tunnels deform during construction due to various features other than the earth pressure and water pressure, and the temporary loads remain for long period. It is thought that one of the reasons of this phenomenon is the existence of backfill grouting between the segment and ground.
2. If the effect of operational loads of shield machine does not exist under normal conditions of construction, the tunnel would be under an ultimately stable condition while subjected only to the earth and water pressure, but the earth pressure often varies to a considerable extent. This fact seems to show that the ground deformation during construction depends not only on the ground condition but also on the construction condition and intensive ground failures sometimes occurs due to the backfill grouting.

From the above facts, we can conclude that the segment designing requires detailed construction conditions. However, it is impossible to clarify the construction conditions, since the information for this purpose is limited when we start designing. Therefore, shield tunneling must be executed not to exceed the allowable stresses of materials of a segment, which is designed on the assumed earth and water pressure.

At present, the excessive stresses are not observed during construction in the above-mentioned practice. However, there will be uncertainties in keeping the quality of shield tunnels in the future, as in the past, under severe tunneling conditions in deeper or greater cross-section shields.

As the discussions in this paper focused on the design of the cross-section, the effect of operational jack force was also referred to only in relation to cross-section. Because the jack force directly acts in the tunnel axis direction, it is important to evaluate its effect in the longitudinal direction.

To maintain the same quality of shield tunnel as that in the past, under severer conditions, it is important that the loads during construction stage properly be included in design. To realize this idea, it is necessary to develop a simple measuring system to grasp the behavior of tunnel and ground during construction, collect the measured data and accumulate experience. It is also important to develop a methodology, which reflects actual practices.

7. Concluding remarks

In Japan, the techniques for shield tunneling construction have been progressing remarkably. They are now capable of counteracting many severe conditions. However, new techniques have recently been developed in segments, which are permanent structures. It seems, however, that the present state of the design of segments is only at the starting point of progressing from traditional methods, which are based on experience. The design of segments is not keeping in step with the progress of constructional techniques.

It cannot be contradicted that such a state hinders the positive adoption of new shield tunneling methods. On account of the well-balanced progress between construction and design in the shield tunneling method, solutions for these problems are required. Then, it is important to understand the actual behavior of tunnel and ground during construction procedure and their stable state in the long term through collection and analysis of measured data.

References

- Ariizumi, T., Okadome, K., Nagaya, J., 1998. Results and analysis on site measurement of load acting on the shield tunnel (in Japanese). *Proc. Tunnel Engineering JSCE* 8, 367–372.
- Ariizumi, T., Okadome, K., Igarashi, H., Nagaya, J., 1999. Investigation of the load acting on shield segments during tunneling (in Japanese). *Proc. Tunnel Engineering JSCE* 9, 271–276.
- Fujii, K., Mashimo, H., Ishimura, T., 2000. Load acting on shield tunnel in gravel ground (in Japanese). *Proc. Tunnel Engineering JSCE* 10, 257–262.
- Hirata, T., 1989. Study on Ground Movement Caused by Shield Driving and Improvement of Shield Tunneling Method. Doctoral Thesis (in Japanese). Kyoto University, pp. 100–110.
- I.T.A. Working Group No. 2. (ITA), 2000. Guidelines for the design of shield tunnel lining. *Tunneling Underground Space Technol.* 15(3), 303–331.
- Itoh, H., Saito, M., 1991. Result and consideration of field measurement acting on the shield tunnel (in Japanese). *Proceedings of the 46th Annual Conference of the JSCE*, Vol. 3. pp. 160–161.
- Kashima, Y., Kondo, N., 1997. Construction of extremely close-set tunnels using the muddy soil pressure balanced rectangular shield method. *Proceedings of World Tunnel Congress '97*. Balkema, Rotterdam, pp. 255–260.
- Kashima, Y., Kondo, N., 1997. Construction of extremely close-set tunnels using the muddy soil pressure balanced rectangular shield method. *Proceedings of World Tunnel Congress*. Balkema, Rotterdam, pp. 255–260.

- Koyama, Y., 2000a. Study on the Improvement of Design Method of Segments for Shield-driven Tunnels (in Japanese). RTRI Report: Special No. 33. RTRI p. 114.
- Koyama, Y., 2000b. Study on the Improvement of Design Method of Segments for Shield-driven Tunnels (in Japanese). RTRI Report: Special No. 33. RTRI p. 131.
- Koyama, Y., 2000c. Study on the Improvement of Design Method of Segments for Shield-driven Tunnels (in Japanese). RTRI Report: Special No. 33. RTRI, pp. 156–163.
- Koyama, Y., 2000d. Study on the Improvement of Design Method of Segments for Shield-driven Tunnels (in Japanese). RTRI Report: Special No. 33. RTRI, pp. 80–83.
- Koyama, Y., 2000e. Study on the Improvement of Design Method of Segments for Shield-driven Tunnels (in Japanese). RTRI Report: Special No. 33. RTRI, pp. 47–55.
- Koyama, Y., Okano, N., Shimizu, M., Fujiki, I., Yoneshima, K., 1995. In-situ measurement and consideration on shield tunnel in diluvium deposit (in Japanese). *Proc. Tunnel Engineering* 5, 385–390.
- Matsumoto, Y., 1994a. The Most Novel Shield Tunnel Technologies (in Japanese). *Nikkei BP* p. 119.
- Matsumoto, Y., 1994b. The Most Novel Shield Tunnel Technologies (in Japanese). *Nikkei BP* p. 133.
- Nishizawa, K., Shiotani, T., Tsutiya, K., Mima, K., Hashimoto, T., Nagaya, J., 1995. The field measurement of the earth pressure on the segments in the diluvium sand (in Japanese). *Proceedings of the 50th Annual Conference of the JSCE*, Vol. 3. JSCE, pp. 1318–1319.
- Nishizawa, K., Shiotani, T., Tsutiya, K., Mima, K., Hashimoto, T., Nagaya, J., 1996. The field measurement of the earth pressure on the segments in the stiff clay (in Japanese). *Proceedings of the 31st Japan National Conference on Geotechnical Engineering*. The Japan Geotechnical Society, pp. 2289–2290.
- Okada, H., Kishi, T., Yoshida, R., Sugishima, T., Onawa, H., 1996. A study on behavior of shield tunnel lining with large section and large depth at sharply curved portion (in Japanese). *Proc. Tunnel Engineering* 6, 399–404.
- Railway Technical Research Institute (RTRI), 1997. Design Standard for Railway Structures (Shield-Driven Tunnel) (in Japanese). Maruzen, pp. 47–61.
- Sakai, K., Tazaki, K. (2003). Development and applications of diaphragm walling with special section steel—NS-Box, *Tunnelling Underground Space Technol*, in press.
- Tokyo Electric Power Co., Ltd. (TEPCO), 1998. Report on Improvement Railway of Shield Tunneling (in Japanese).