



10th International Conference on Mechanical Engineering, ICME 2013

Transient stability improvement of a fixed speed wind driven power system using permanent magnet synchronous generator

Zinat Tasneem*, M.R.I. Sheikh

EEE Department, Rajshahi University of Engineering & Technology, Rajshahi 6204, Bangladesh

Abstract

The aim of this paper is to improve the transient stability of a wind turbine generation system (WTGS), so that it can respond to a disturbance or fault of the system from a normal operating condition and can return to a state where their operation is normal again. A comparison for transient stability augmentation capability between Induction Generator (IG) and Permanent Magnet Synchronous Generator (PMSG) has been explained. For this, three models have been presented, all of them having a total capacity of 6MVA. The models are: wind farm with IG alone, with both IG and PMSG and a wind farm with PMSG alone. It is seen that the transient stability of IG can be improved by including PMSG with IG. The simulation models have been prepared with the simulation tool of PSCAD/EMTDC.

© 2014 The Authors. Published by Elsevier Ltd. This is an open access article under the CC BY-NC-ND license (<http://creativecommons.org/licenses/by-nc-nd/3.0/>).

Selection and peer-review under responsibility of the Department of Mechanical Engineering, Bangladesh University of Engineering and Technology (BUET)

Keywords: Permanent Magnet Synchronous generator (PMSG) ; Fault ; Transient Stability ; Induction Generator (IG).

1. Introduction

Wind is a promising source of renewable energy and it is currently one of the most cost effective ways to produce electricity. The average annual growth rate of wind turbine installation is around 30% during last ten years. By the end of 2020, it is expected that this figure will increase to well over 1,260,000MW, which will be sufficient for 12% of the world's electricity consumption [1]. Since, the demand for wind energy is increasing very rapidly, it is important to assure a good quality of the power delivered and an enhanced transient stability of the wind farm, so that the wind farm can overcome the fluctuations caused by the fault as quickly as possible.

* Corresponding author. Tel.: +8801719533263; fax: +0-000-000-0000 .
E-mail address: tasneemzinat@gmail.com

One of the most popular wind generator schemes is the fixed speed wind turbine system using a multi-stage gear box and a standard squirrel cage Induction Generator (IG). IGs are used worldwide as a fixed speed wind generator due to their superior characteristics such as brushless and rugged construction, maintenance free, low cost and simplicity of operation [2]. But IG requires a large reactive power to recover the air gap flux when a short circuit fault occurs in a power system [3]. Hence, the electromagnetic torque becomes largely different than the mechanical torque, in such a condition, the generator might have to be disconnected from the power system. If the generator of the wind farm needs to be disconnected, then the power system will be seriously hampered. Therefore it is important to investigate for an appropriate method to enhance the transient stability. Recently, voltage or current source inverter based Flexible AC Transmission System (FACTS) devices such as Static VarCompensator (SVC), Static Synchronous Compensator (STATCOM), Dynamic Voltage Restorer (DVR), Solid State Transfer Switch (SSTS), and Unified Power Flow Controller (UPFC) have been used for flexible power flow control, secure loading and dumping of power system oscillations [4-6]. Though these devices contribute to control power flow and enhance fault ride through capability to some extent, they are the non-producing element for a wind farm, they make the system more complicated and increase the system overall cost.

Now a days, the fixed speed wind turbine is increasingly being dominated by the variable speed wind turbine (VSWT) generation system. The variable speed Wind Turbine Generation System (WTGS) equipped with fully or partially rated power electronic converters has strong fault ride through capability during the network disturbance [7]. In recent years, Variable Speed Wind Turbine with Permanent Magnet Synchronous Generator has become the most popular type of wind generator. Permanent magnet machines are characterized as having large air gaps, which reduce flux linkage even in machines with multi-magnetic poles [8]. They can be directly connected to the wind turbine without gearbox which has been found as the most critical component especially during fault [9].

In [10] a transient stability enhancement technique has been discussed, however a complex control technique for frequency converter is used there. Therefore, in this study, a new topology to enhance the transient stability of small scale wind farm including IG is considered with different combination of IG and PMSG. Also simple frequency converter is used for PMSG. It has been proved, that the new technique used in this paper is capable of improving the transient stability of the wind farm effectively, thus reducing the cost of overall system.

2. Proposed Model

The model system used for the transient stability analysis is shown in the Fig.1. IG and PMSG have been used for this model. Here, one IG of 6 MVA is connected to a 66 kV line through a step up (0.69/66 kV) transformer. A capacitor bank C is connected to the terminal of IG. The value of capacitor bank C is chosen so that power factor of the wind generator during the rated operation becomes unity [2]. Another wind farm is composed of PMSG (6MVA) only. It is also connected to a 66 kV line through a fully rated frequency converter and a step up (0.69/66 kV) transformer. The third connection scheme consists of both IG (3 MVA) and PMSG (3 MVA) connected to a 66 kV line with the same step-up transformer. Table 1. showsthe parameters of IG and PMSG respectively.

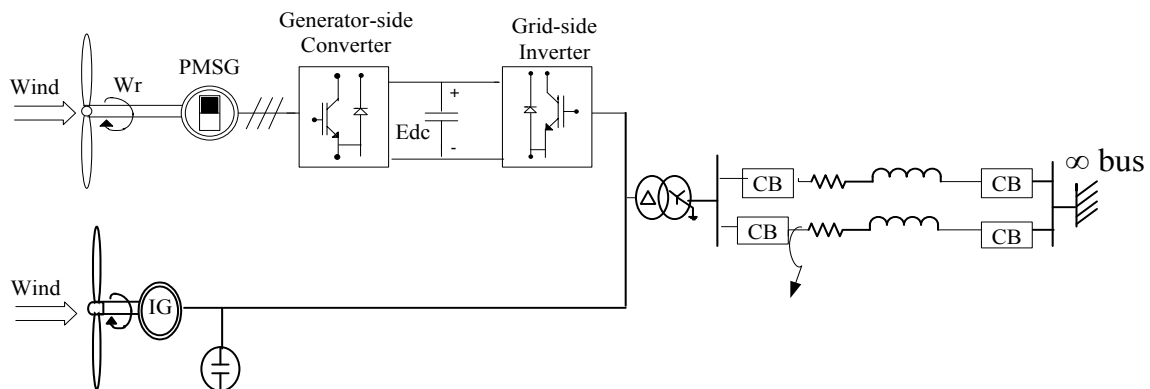

Fig. 1. The Proposed Model of a Wind Farm.

Table 1. Generator Parameters.

PMSG		IG	
Rated power	6 [MVA]	Rated Power	6 [MVA]
Rated Voltage	0.69 [kV]	Rated Voltage	0.69 [kV]
Frequency	20 [Hz]	Frequency	50 [Hz]
d-axis reactance, X_d	1.0 [pu]	Stator resistance	0.01 [pu]
q-axis reactance, X_q	0.7 [pu]	Leakage reactance	0.1 [pu]
Stator winding resistance	0.01 [pu]	Magnetizing reactance	3.5 [pu]
Stator leakage resistance	0.064 [pu]	Rotor Mutual reactance	0.12 [pu]
Magnetic strength	1.4 [pu]	H	1.5 s

3. Wind Turbine Modeling

The model of wind turbine rotor is complicated. According to the blade element theory [11], modelling of blade and shaft needs complicated and lengthy computations. Moreover, it also needs detailed and accurate information about rotor geometry. Therefore, considering only the electrical behaviour of the system, a simplified method of modelling of the wind turbine blade and shaft is normally used [2]. The mathematical relation for the mechanical power extraction from the wind can be expressed as follows [11].

$$P_m = \frac{1}{2} \rho \pi R^2 V \omega^3 C_p(\lambda, \beta) \tag{1}$$

Where, P_m is the mechanical power that the turbine extracts from the wind, ρ is the air density (Kg/m^3), R is the blade radius (m) and C_p is the power coefficient which is a function of both, tip speed ratio, λ , and blade pitch angle, β (deg). λ and C_p are expressed as [2]:

$$\lambda = \frac{\omega R}{V_w} \tag{2}$$

Where, ω is the wind turbine angular speed (rad/s), V_w is the wind speed (m/s). The power coefficient, C_p is,

$$C_p = \frac{1}{2} (\Gamma - 0.022\beta^2 - 5.6) e^{-0.17\Gamma} \tag{3}$$

Since, C_p is expressed in feet and mile, Γ is corrected as,

$$\Gamma = \left(\frac{R}{\lambda}\right) \left(\frac{3600}{1609}\right) \tag{4}$$

The torque coefficient, C_T , is given by

$$C_T = \frac{C_p(\lambda)}{\lambda} \tag{5}$$

The wind turbine torque is expressed as,

$$T_m = \frac{1}{2} \rho \pi R^3 V_w^2 C_T(\lambda) \tag{6}$$

4. PMSG Model

For PMSG, the generator speed is derived from the mechanical rotor speed ω_r and the number of poles n_p , because the generator is directly coupled to the wind turbine rotor.

$$f_e = \frac{n_p}{2} \cdot f_m = \frac{n_p}{2} \cdot \frac{\omega_r}{2\pi} \tag{7}$$

The generation system is composed of a PMSG and a full rating power converter. In power system analysis, the magnetic flux distribution around the air gap of a synchronous generator is assumed to be sinusoidal. Therefore the flux distribution in the stator is sinusoidal, and the electromotive forces are also sinusoidal [12]. The induced voltage E_g generated by the permanent magnets can be expressed as:

$$E_g = 2\pi \cdot f_e \cdot \psi_m = \omega_e \cdot \psi_m \tag{8}$$

where, ψ_m is the flux linkage of stator coil.

A commonly used PMSG transient model is the park model. In order to get a dynamic model for the generator that easily allows us to define the generator control system, the equations of the generator are projected on a reference coordinate system rotating synchronously with the magnetic flux as shown in Fig. 2.

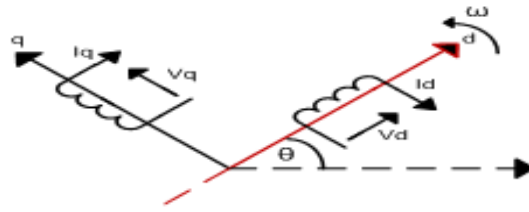

Fig. 2.The Park Model of PMSG.

With sinusoidal distribution of conductors and flux are linear functions of currents I_d and I_q situated on the rotor. They are given by the equations [12]:

$$\begin{cases} \psi_d = L_d I_d + \psi_f(\theta) \\ \psi_q = L_q I_q \end{cases} \quad (10)$$

Where, L_d : Stator inductance in d-axis; L_q : Stator inductance in q-axis; (L_d and L_q are supposed independent of θ); f : Magnetic flux;

The wind turbine driven PMSG can be represented in the rotor reference frame as:

$$\begin{bmatrix} I_d \\ I_q \end{bmatrix} = \begin{bmatrix} \sqrt{\frac{2}{3}} \cos \theta & \cos \left(\theta - \frac{2\pi}{3} \right) \\ \sqrt{\frac{2}{3}} -\sin(\theta) & -\sin \left(\theta - \frac{2\pi}{3} \right) \end{bmatrix} \begin{bmatrix} I_a \\ I_b \\ I_c \end{bmatrix} \quad (11)$$

$$\begin{bmatrix} I_d \\ I_q \end{bmatrix} = \begin{bmatrix} \sqrt{\frac{2}{3}} \cos \theta & \cos \left(\theta - \frac{2\pi}{3} \right) \\ \sqrt{\frac{2}{3}} -\sin(\theta) & -\sin \left(\theta - \frac{2\pi}{3} \right) \end{bmatrix} \begin{bmatrix} I_a \\ I_b \\ I_c \end{bmatrix} \quad (12)$$

The equations of voltage are:

$$V_a = \sqrt{\frac{2}{3}} [V_d \cos(\theta) - V_q \sin(\theta)] \quad (13)$$

$$V_b = \sqrt{\frac{2}{3}} [V_d \cos \left(\theta - \frac{2\pi}{3} \right) - V_q \sin \left(\theta - \frac{2\pi}{3} \right)] \quad (14)$$

$$V_c = \sqrt{\frac{2}{3}} [V_d \cos \left(\theta + \frac{2\pi}{3} \right) - V_q \sin \left(\theta + \frac{2\pi}{3} \right)] \quad (15)$$

The electromagnetic torque can be expressed as:

$$\tau = \frac{3}{2} P [(L_q - L_d) I_q I_d + I_q \psi_f] \quad (16)$$

4.1. Generator side converter and grid side inverter

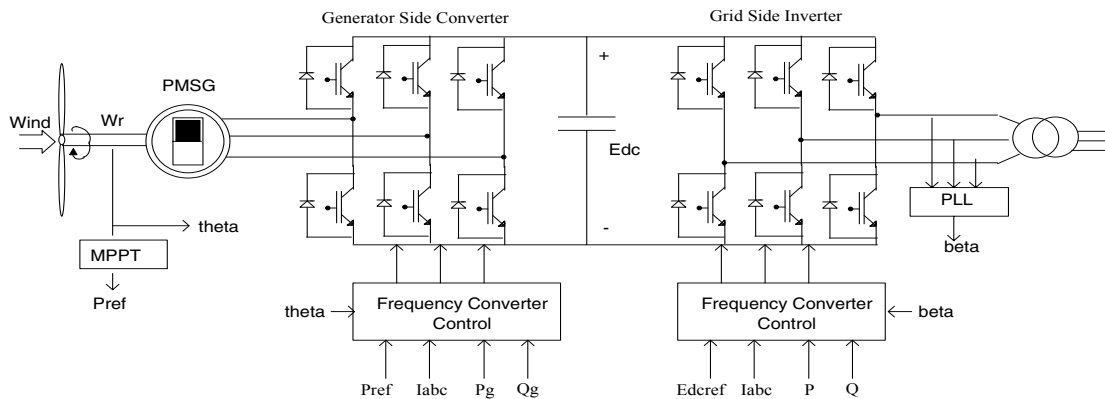

Fig. 3. Control Scheme for VSWT-PMSG.

Fig.3 shows the simple control structure for VSWT-PMSG. Control strategies are built mainly to control the generator side converter and grid side inverter. The generator side converter is connected to the stator of the PMSG and it decouples the generator from the rest of the network. Hence the generator rotor and wind turbine rotor can rotate freely. It consists of MPPT, Proportional Integral (PI) controllers and abc/dq and dq/abc converters.

The aim of the grid side inverter is to keep the dc link voltage constant, so it ensures that the network is fed by the active power generated by the PMSG. Moreover, it is possible to control the reactive power fed to the grid. It consists of Phase Locked Loop (PLL), PI controllers and abc/dq and dq/abc converters.

5. Simulation Results and Analysis

A new wind farm topology is presented in this paper, which is composed of both fixed and variable speed wind generators. The transient stability of the system is analyzed. The frequency converters are controlled in such a way that the output parameters, like, grid side voltage, power, frequency etc are maintained at the desired level, and after the clearing of fault; they can be restored as quickly as possible. The fault occurs at 35s, the circuit breakers on the faulted line are opened at 35.1s and 35.2s, and the fault is cleared within 0.05s. Simulations have been done by using Power System Computer Aided Design / Electromagnetic Transient including DC (PSCAD/EMTDC) [13] program for 80 seconds. The timing step of the simulation is chosen to be 0.001 sec. The simulation results are shown below. Fig.4 shows the grid side voltage. For IG the grid side voltage varies and its transient response is not acceptable, but the transient stability of the farm is quite improved by using both PMSG and IG. The PMSG working alone quickly responded to the fault and return to the pre-fault level very quickly. Fig.5 shows the active power output of the wind farms, where the PMSG again makes the active power output more stable at transient conditions.

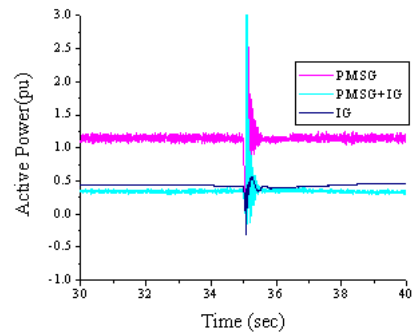
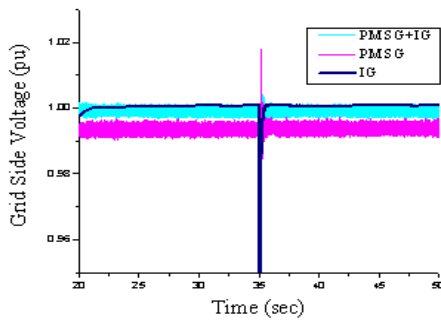

Fig.4. Terminal voltages of the wind farms. Fig. 5. Active power outputs of the wind farms.

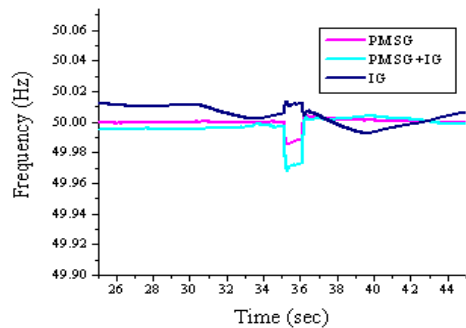
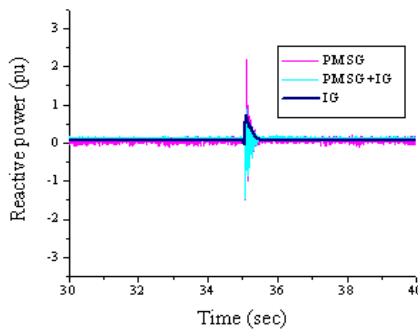

Fig.6. Reactive power output of the wind farms.

Fig. 7. Grid side frequency of the wind farms.

Fig.6 shows the reactive power output of the wind farms. The grid side inverter of PMSG is able to supply necessary reactive power during severe symmetrical 3LG fault, which can be seen from this figure. Fig.7 shows the frequency obtained at the grid side. Response of frequency is also improved by the proposed model at transient condition. All the simulation results show the effectiveness of the proposed wind farm, transient response of the wind farm is increased for the grid side parameters.

6. Possible Application in the Wind Farm of Bangladesh (Kutubdia)

Simulation results show that the wind farm scheme used in this paper is not only capable of supplying constant power at the grid against variable wind speed, but also it can enhance the transient stability with grid fault ride through capability. So, the proposed scheme can be applicable to the coastal areas of Bangladesh especially at Kutubdia Island, where a hybrid wind farm of a total capacity of 1MW has already been installed. Moreover the proposed model can also be used to supply a good quality of power directly to the grid with an increased transient stability, making the overall project cost effective. Therefore, it may be of worth to check whether the proposed model can work and improve the response of the wind farm of Bangladesh.

7. Conclusion

To improve the transient stability, various FACTS devices have been used in fixed speed wind farms for a long time. But, these non-producing elements need extra maintenance, moreover they increase the system overall cost. To solve this problem, a new topology has been introduced in this paper which is composed of both fixed and variable speed wind generators. The fully controlled frequency converters of PMSG have the ability to control the reactive power flow. This makes the wind farm more stable during faulty conditions; the fixed speed wind generators receive their required reactive power from the VSWT-PMSG during network disturbance. The simulation results shown in this paper prove the ability of the proposed control topology. The transient stability of the system is improved effectively. Finally, it is concluded that, the proposed system is a good tool for power system transient stability improvement by contributing to the electrical output and eliminating the costs of external power control devices. This method is equally effective for both new wind farms and for existing wind farms where expansion of installed capacity is required.

References

- [1] The Global Wind Report Annual market update 2012", Global Wind Energy Council, 2013.
- [2] M.R.I. Sheikh, S.M. Muyeem, R. Takahashi, T. Murata, J. Tamura, Wind Generator Stabilization by PWM Voltage Source Converter and Chopper Controlled SMES, *J. of Int. Review of Automatic Control* 3 (2008) 311-320.
- [3] C. L. Souza et al., Power system transient stability analysis including synchronous and induction generator, *Proc. IEEE Porto Power Tech* 2 (2001) 6.
- [4] H.F. Wang, F. Li, R.G. Cameron, FACT control design based on power system non parametric model, *IEEE Proc.-Gener. Trans. Distrib.* 146 (1999) 409-415.
- [5] L. Gyugyi, Unified power flow control concept for flexible ac transmission system, *Proc. Inst. Elect. Eng. C* 139 (1992) 323-331.
- [6] L. Gyugyi, Dynamic compensation of AC Transmission line by solid state synchronous voltage source, *IEEE Trans, Power Delivery* 9 (1994) 904-911
- [7] A. D. Hansen and G. Michalke, Modelling and control of variable-speed multi-pole permanent magnet synchronous generator wind turbine, *Wind Energy*, 11 (2008) 537-554.
- [8] T. J. E. Miller, *Brushless Permanent-Magnet and Reluctance Motor Drives*. New York: Oxford Univ. Press, 1989.
- [9] J. Ribrant, L. M. Bertling, Survey of failures in wind power systems with focus on Swedish wind power plants during 1997-2005, *IEEE Trans. Energy Convers.*, 22 (2007) 167-173.
- [10] S.M. Muyeem, R. Takahashi, T. Murata, J. Tamura, A Variable Speed Wind Turbine Control Strategy to Meet Wind Farm Grid Code Requirements, *IEEE Transactions* 25 (2010) 331 - 340.
- [11] S. Heier, *Grid Integration of Wind Energy Conversion System*, John Wiley & Sons Ltd., 1998.
- [12] P. Kundur, *Power System Stability and Control*, McGraw-Hill, New York 1994.
- [13] PSCAD/EMTDC Manual. 1994. Manitoba HVDC Research Center.