

Compact reconfigurable power divider with low insertion loss



Bingkun Hu, Kaijun Song*, Maoyu Fan, Yu Zhu

EHF Key Laboratory of Science, School of Electronic Engineering, University of Electronic Science and Technology of China, Chengdu 611731, China

ARTICLE INFO

Article history:

Received 6 July 2015

Accepted 6 March 2016

Keywords:

Reconfigurable power divider

Varactor diodes

Compactness

Low insertion loss

ABSTRACT

A compact low insertion loss reconfigurable power divider using two varactor diodes is presented in this letter. Design methods along with analysis equations are provided. The reconfigurable responses are realized by tuning the controlling voltages of the two varactor diodes thereby resulting compact size and less loss. One diode is used to tune the return loss of the input port and the other diode is utilized to tune the return loss of the two output ports and the isolation between the two ports. The tuning frequency range is from 0.7 GHz to 1.01 GHz. A reconfigurable power divider is designed, fabricated and measured to validate the proposed methods. The power divider has the merits of compactness, low insertion loss, good isolation between two output ports, good return loss, and only two varactor diodes.

© 2016 Elsevier GmbH. All rights reserved.

1. Introduction

Recently, the development in the wireless communication systems have made more demands on the circuits' integration, which means that the circuit with a compact size can realize more functions than before. For example, a component with the reconfigurability can possibly make the wireless system easy to integrate, such as a reconfigurable filter [1–4]. Meanwhile, power divider is an important device in the wireless communication systems [5–11]. It is usually used in the feeding network of the antenna, balanced amplifier and power combining. So a power divider with the reconfigurable ability can enhance the circuit design flexibility and cater to the demands mentioned before.

There are several functions of reconfigurability in the power divider's design, such as the number of the output ports, the working frequency and the power dividing ratio [12–16]. In [12], switches were used to change the states of the output ports number. The working frequency was fixed and the four working states can be changed. However, the six pin diodes used in the power divider's design made the circuit and the feed of the diodes complex, which made the insertion loss worsen. In [13], a power divider with tunable frequency ability was presented. Four BST (barium–strontium–titanate) varactors were used to change the working frequency continuously. The circuit had a compact size owing to the usage of varactors. However, due to the four varactors used, the power divider's insertion loss was larger than 1.2 dB.

In [14], a power divider with tunable power ratio was proposed. The circuit included three impedance transformers and required a single biasing voltage control. Because of the usage of only two diodes, the power divider's insertion loss was 0.6 dB. In general, in the reconfigurable systems, the utilization of many diodes, such as pin diodes or varactor diodes, may complicate the structure and deteriorate the insertion loss.

In this letter, a compact reconfigurable power divider with the working frequency from 0.7 GHz to 1.01 GHz is designed and fabricated. The working frequency can be tuned continuously. In order to enhance the circuit's performance and reduce the circuit's size, only two varactor diodes with different biasing voltages are used to realize the configurability. The two diodes separately tune the return loss of the input port and the return loss of two output ports along with the isolation between the two output ports. Compared to other works done before [11–15], the proposed tunable power divider has the advantages of small size, low insertion loss, good isolation, good return loss and only two diodes.

2. Analysis and design of the reconfigurable power divider

Fig. 1 illustrates the topology of the proposed compact reconfigurable power divider. The proposed power divider is composed of two branches transmission lines and two diodes.

Varactor diode A is connected between the two output ports. It is employed to tune the return loss of the output ports and the isolation. Meanwhile, another diode which is used to tune the return loss of the input port is placed at the input port and connected to the ground.

* Corresponding author. Tel.: +86 13708195502.

E-mail addresses: ksong@uestc.edu.cn, kaijun.song@hotmail.com (K. Song).

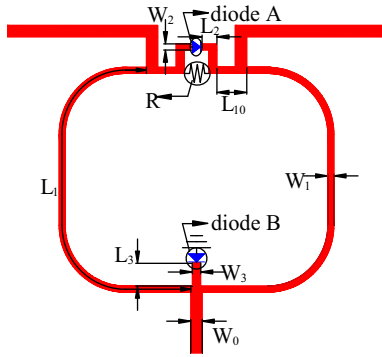

Fig. 1. Structure of the proposed tunable power divider.

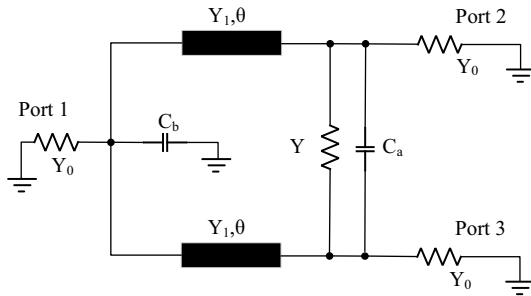

Fig. 2. Equivalent circuit model of the proposed power divider.

Fig. 2 illustrates the equivalent circuit model of the designed power divider. The two varactor diodes are replaced with the two different capacitors to simplify the analysis. The Y_0 at each port is the admittance of the source and load. The Y located between the two output ports is the admittance of the isolation resistor. Fig. 3 shows the odd and even mode analysis of the proposed power divider. In the odd mode condition, as can be seen in Fig. 3(a), the following equation can be deduced:

$$Y_{odd2} = -jY_1 \cot \theta + 2Y + 2\omega C_a \quad (1)$$

If the output port satisfies the impedance match, then Eq. (2) can be deduced.

$$j2\omega C_a - jY_1 \cot \theta + 2Y = Y_0 \quad (2)$$

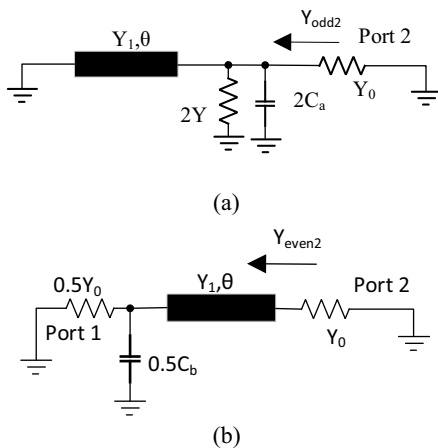

Fig. 3. Odd and even mode analysis of the power divider. (a) Odd mode analysis. (b) Even mode analysis.

Table 1

Comparison between the simulated and the calculated values of C_a and C_b at different frequency (sim: simulated, cal: calculated).

	1.01 GHz		0.85 GHz		0.7 GHz	
	sim	cal	sim	cal	sim	cal
C_a (pF)	0.466	0.36	0.6	0.72	1.08	0.93
C_b (pF)	0.466	0.72	1.2	1.44	2.05	1.86

When the isolation resistor satisfies the equation $2Y = Y_0$, the equivalent capacitor can be deduced using the following equation

$$C_a = \frac{Y_1}{2\omega \tan \theta} \quad (3)$$

where the ω is the angular frequency, θ is the electrical length of the transmission line, Y_1 is the characteristic admittance of the transmission line and C_a is the equivalent capacitor of the diode A.

Fig. 3(b) illustrates the block diagram of the even mode analysis. The symmetrical wall can be seen as a magnetic wall. In order to maintain a good return loss of the input port, another diode is connected to the input port. Using the transmission line theory and the impedance matching theory, the impedance Y_{even2} looking from port 2 can be calculated as follows:

$$Y_{even2} = Y_1 \frac{jY_1 \tan \theta + 0.5Y_0 + j0.5\omega C_b}{Y_1 + j(0.5Y_0 + j0.5\omega C_b) \tan \theta} \quad (4)$$

In order to maintain good impedance match, Y_{even2} should equal to Y_0 . So the following equation can be deduced.

$$jY_1^2 \tan \theta - j\frac{1}{2}Y_0^2 \tan \theta + j\frac{1}{2}Y_1\omega C_b - \frac{1}{2}Y_1Y_0 + \frac{1}{2}Y_0 \tan \theta \omega C_b = 0 \quad (5)$$

where C_b is the equivalent capacitor of the diode B.

If the imaginary part $Y_1\omega C_b$ is small and $Y_1^2 = Y_0^2/2$, then Eq. (3) can be approximately fulfilled. The real part should satisfy the equation

$$\frac{1}{2}Y_1Y_0 - \frac{1}{2}Y_0 \tan \theta \omega C_b = 0 \quad (6)$$

Then the diode B's equivalent capacitor can be calculated using the following equation

$$C_b = \frac{Y_1}{\tan \theta \omega} \quad (7)$$

3. Simulation and measurement

In order to testify the proposed method, a reconfigurable power divider using the above topology is constructed on substrate Taconic RF-35 with a relative dielectric constant of 3.5, thickness of 0.508 mm and loss tangent of 0.0018. The varactor diode is Skyworks' SMV1231 with the equivalent capacitor ranging from 0.466 pF to 2.35 pF. Table 1 shows the details of the calculated and simulated capacitor of C_a and C_b . As can be seen, difference is not big at the working frequency 0.7 GHz. But the difference deteriorates when the frequency moves higher which is caused by the range of the diodes' equivalent capacitors. The diode's equivalent capacitor ranges from 0.466 to 2.35 pF, which means this cannot be reached when the power divider works at 1.01 GHz. So some compromises of the C_a and C_b have been made in order to make the power divider works well.

Commercial software Advanced design system 2011 is used to optimize the power divider. The final parameters of the proposed power divider are as follows: $W_0 = 1.14$ mm, $L_{10} = 2.97$ mm, $L_1 = 37.396$ mm, $W_1 = 0.62$ mm, $L_2 = 1.48$ mm, $W_2 = 0.83$ mm, $L_3 = 2.238$ mm, $W_3 = 0.83$ mm, $R = 100 \Omega$. The photograph of the power divider after fabrication with the bias copper wires is

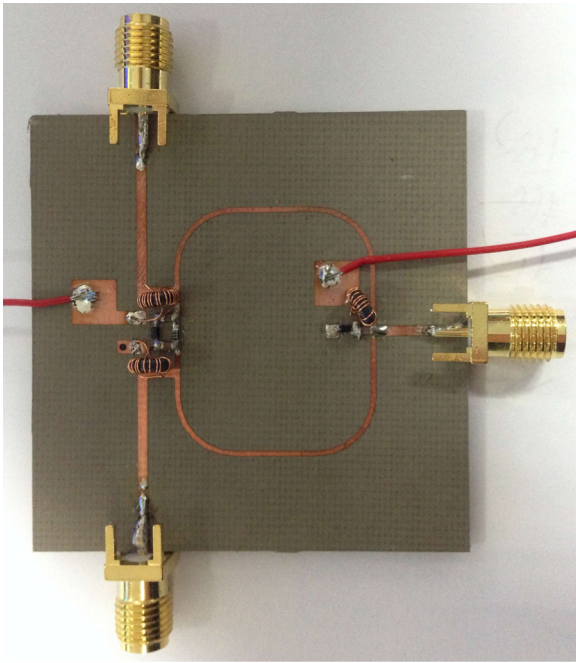

Fig. 4. Photograph of the fabricated power divider.

displayed in Fig. 4. Note that the power divider's varactor diodes are biasing using different biasing pads. The biasing circuits include inductors, capacitors and diodes. Inductors are used to cut off the RF frequency and give the diodes proper voltages. The capacitors used here are 1 μ F which are employed to give the A and B diodes different voltages. Fig. 5 shows the details of the diodes A and diodes B's biasing circuits. The total area of the proposed reconfigurable power divider is $0.160\lambda_g \times 0.148\lambda_g$, where λ_g is the guided wavelength at the center frequency (0.85 GHz).

With the demonstration of the power divider's reconfigurability, measured and simulated S_{11} are shown in Fig. 6(a). As can

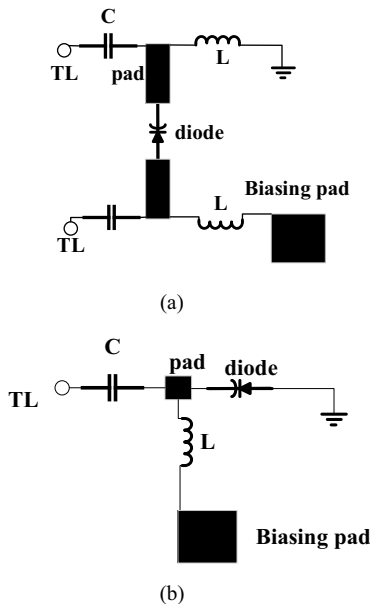
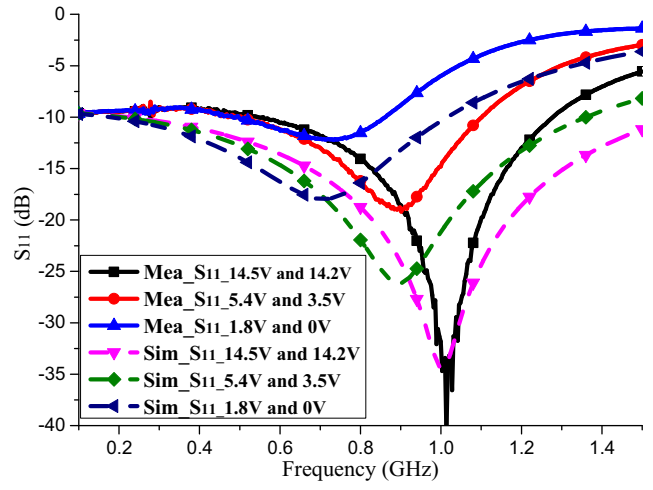
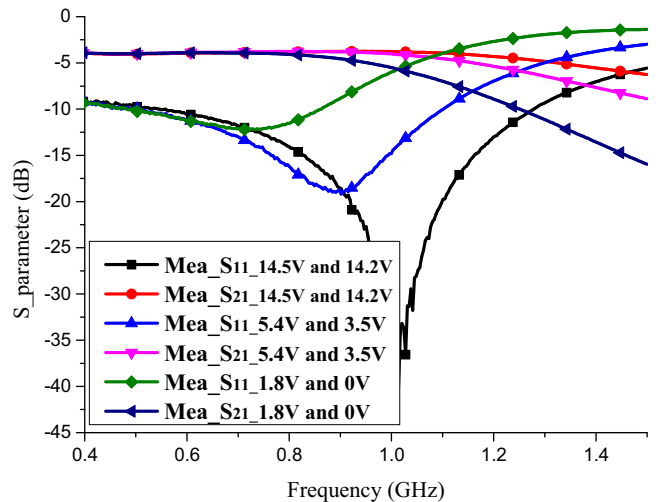

Fig. 5. (a) Biasing circuit of diode A, (b) biasing circuit of diode B (TL: transmission line).



(a)



(b)

Fig. 6. (a) Return loss at the input port with different biasing voltages of diode A and B. (b) Measured insertion loss and return loss at the input port.

be seen, the working frequency can be tuned from 0.7 GHz to 1.01 GHz. Meanwhile, measured insertion loss and return loss at the input port are also provided in Fig. 6(b). This indicates that the edge of the S_{21} decays when the working frequency moves lower. Fig. 7 shows the detailed S-parameters of the reconfigurable power divider at different working frequency. In Fig. 7(a), the biasing voltages of diode A and diode B are 14.5 V and 14.2 V separately. The power divider works at the frequency of 1.01 GHz. The measured the return loss is bigger than 15 dB at the working frequency. The measured result of S_{11} agrees with the simulated ones and it is bigger than 30 dB. The isolation figure shows that at the working frequency the isolation is bigger than 13 dB which means the power divider can work well at this frequency. In Fig. 7(b), the biasing voltages are 5.4 V and 3.5 V, the power divider works at the frequency of 0.85 GHz. The return losses of all the three ports are larger than 15 dB, while the isolation is bigger than 25 dB. In Fig. 7(c), the biasing voltages are 1.8 V and 0 V separately. The return loss of the input port is bigger than 12 dB and the isolation between the two output ports is bigger than 15 dB. The designed power divider has the merits of low loss. From the working frequency 0.7–1.01 GHz, the insertion loss is less than 1 dB at the center frequency.

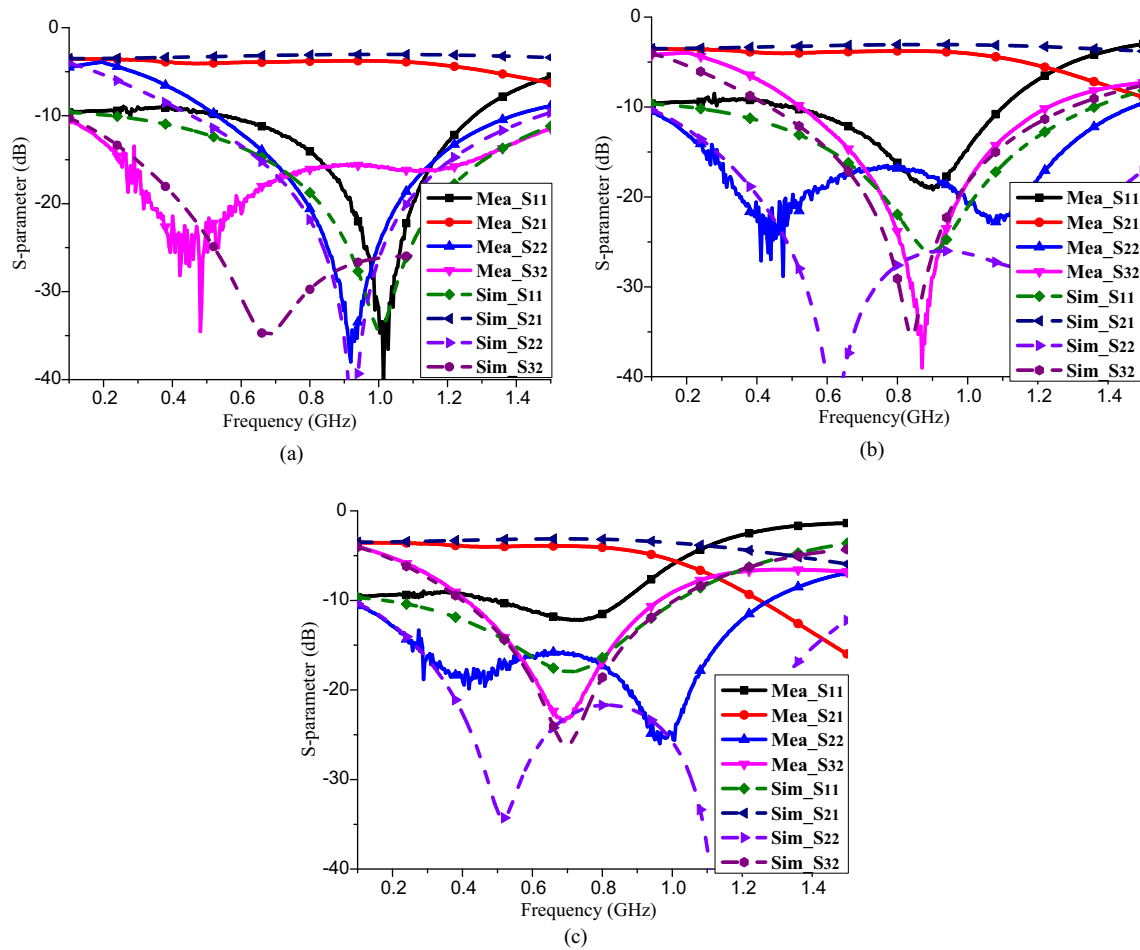

Fig. 7. S-parameters performance of the proposed reconfigurable power divider with biasing voltages of diode A and diode B. (a) 14.5 V and 14.2 V, (b) 5.4 V and 3.5 V, and (c) 1.8 V and 0 V.

4. Conclusion

This letter has presented a novel reconfigurable power divider using varactor diodes. By tuning the biasing voltages of diodes, the power divider can work at the frequency from 0.7 GHz to 1.01 GHz. Simultaneously, the isolation between the two output ports and the return loss of all the three ports works well. The insertion loss of all the working frequency is less than 1 dB and the return loss is bigger than 12 dB. The proposed reconfigurable has the merits of low insertion loss, compactness, good isolation, good return loss and only two diodes.

Acknowledgments

The work for this grant was supported by National Natural Science Foundation of China (Grant No: 61271026), by the Program for New Century Excellent Talents in University (Grant No: NCET-11-0066), by the Research Fund of ITS (ITS2013002492), by the Research Fund of Shanghai Academy of Spaceflight Technology (SAST201243), and by the project (No: IRT1113) under “Program for Changjiang Scholars and Innovation Team in University”.

References

- [1] Brown AR, Ann A. A varactor-tuned RF filter. *IEEE Trans Microw Theory Tech* 2000;48(7):1157–60.
- [2] Tombak A, Maria J-P. Voltage-controlled RF filters employing thin-film barium–strontium–titanate tunable capacitors. *IEEE Trans Microw Theory Tech* 2003;51(2):462–7.
- [3] Nath J, Ghosh D. An electronically tunable microstrip bandpass filter using thin-film barium–strontium–titanate (BST) varactors. *IEEE Trans Microw Theory Tech* 2005;53(9):2707–12.
- [4] Zhang XY, Chan CH. RF tunable bandstop filters with constant bandwidth based on a doublet configuration. *IEEE Trans Ind Electron* 2012;59(2):1257–65.
- [5] Song K, Xue Q. Ultra-wideband ring-cavity multiple-way parallel power divider. *IEEE Trans Ind Electron* 2013;60(10):4737–45.
- [6] Scardelletti MC, Ponchak GE. Miniaturized Wilkinson power dividers utilizing capacitive loading. *IEEE Microw Wireless Compon Lett* 2002;12(1):6–8.
- [7] Song K, Mo Y, Xue Q, Fan Y. Wideband four-way out-of-phase slotline power dividers. *IEEE Trans Ind Electron* 2014;61(July (7)):3598–606.
- [8] Woo D, Lee T. Suppression of harmonics in Wilkinson power divider using dual-band rejection by asymmetric DGS. *IEEE Trans Microw Theory Tech* 2005;53(6):2139–44.
- [9] Cheng KM. A new Wilkinson power divider design for dual band application. *IEEE Microw Wireless Compon Lett* 2007;17(9):662–4.
- [10] Song KJ, Xue Q. Ultra-wideband 12-way coaxial waveguide power divider with rotated electric field mode. *IET Microw Antennas Propag* 2011;5(5):512–8.
- [11] Zhang J, Li L, Gu J, Sun X. Compact and harmonic suppression Wilkinson power divider with short circuit anti-coupled line. *IEEE Microw Wireless Compon Lett* 2007;17(9):661–3.
- [12] Zhang J, Li L, Gu J, Sun X. Reconfigurable 1:4 power divider with switched impedance matching circuits. *IEEE Microw Wireless Compon Lett* 2012;22(2):64–6.
- [13] Errikos L. Reduced size and tunable microwave circuits using BST thin-film varactors. *IEEE Trans Microw Theory Tech* 2008;56(12):3093–9.
- [14] Tang WJ. Compact, tunable Wilkinson power divider using tunable synthetic transmission line. *Microw Opt Technol Lett* 2010;52(6):1434–6.
- [15] Wdala S, Akil J. A compact three ports power divider with tunable power ratio. *Microw Opt Technol Lett* 2013;55(2):357–63.
- [16] Kim S, Jeong J. Reconfigurable 1:3 power divider using coupled lines. *Electron Lett* 2009;45(22):1141–3.