

The Quality of Accounting Information

Fred de Koning

Nyenrode Business University (Breukelen, The Netherlands).

Address details:

Prof. Dr. W.Fred. de Koning
Nyenrode Business University
Straatweg 25, 3621 BG Breukelen, Netherlands
P.O. Box 130, 3620 AC Breukelen, Netherlands
Tel. 0031-346-291211
Fax 0031-346-291264
E-mail: f.dekoning@nyenrode.nl

Abstract

Accounting information is used for both internal and external purposes. The internal information is mainly directed at the control of business processes; the external on reporting financial results and the financial position of the organization. While existing frameworks for controlling and auditing information systems (IS) such as ITIL Version 3 (ITSMF 2007) and CobiT 4.1 (ITGI 2007) present a wide range of applicable IS controls, they are not explicitly directed at the quality of accounting information. More specifically, the semantic aspects of information are glaringly absent. That is, its intended and perceived meaning. The purpose of this article is to create a conceptual framework or starting point for the study of the control measures that should be taken to satisfy the quality demands of the end users of accounting information.

In Section II the concepts that will be used in this article are defined. In Section III some well-known models of information and information systems quality or success and some other approaches to the quality of accounting information are reviewed. The purpose is to find some clues for the measures to be taken to safeguard the most relevant quality characteristics of accounting information. In Section IV we will investigate the controls that will best serve the selected quality characteristics. These controls will be fitted into a framework that will be presented in Section V. Finally, in Section V, conclusions are drawn and recommendations for further research are made.

Introduction

Accounting information is used for both internal and external purposes. The internal information is mainly directed at the control of business processes; the external on reporting financial results and the financial position of the organization. While existing frameworks for controlling and auditing information systems (IS) - such as ITIL Version 3 (ITSMF 2007) and CobiT 4.1 (ITGI 2007) - present a wide range of applicable IS controls, they are not explicitly directed at the quality of accounting information. More specifically, the semantic aspects of information are glaringly absent. That is, its intended and perceived meaning. The purpose of this article is to create a conceptual framework or starting point for the study of the control measures that should be taken to satisfy the quality demands of the end users of accounting information.

In Section II the concepts that will be used in this article are defined. In Section III some well-known models of information and information systems quality or success and some other approaches to the quality of accounting information are reviewed. The purpose is to find some clues for the measures to be taken to safeguard the most relevant quality characteristics of accounting information. In Section IV we will investigate the controls that will best serve the

selected quality characteristics. These controls will be fitted into a framework that will be presented in Section V. Finally, in Section V, conclusions are drawn and recommendations for further research are made.

II. Definitions

The quality of information in general and accounting information in particular are difficult subjects to discuss conceptually. In fact, such discussions may end in terminological squabbling and misunderstandings and add to existing confusion. In short, the so-called cure might prove worse than the disease. In order to sidestep - and, hopefully, altogether avoid - that risk, we will define the most important concepts used in this article. That is, "quality", "information", and "accounting information".

Quality

The study of quality started in the '50's of the last century in mass production environments. Initially, it was thought to be the creation of value. That is, the measure of excellence in relation to costs (Abbot 1955; Feigenbaum 1991). Later on, the focus shifted to the degree to which specific demands were met (Gilmore 1974; Levitt 1972) or how well and to what extent the requirements of customers were satisfied (Crosby 1979). This is reflected in the definition of quality of the International Standardization Organization (ISO 2005): "the degree to which a set of inherent characteristics fulfils requirements". Quality guru Juran (1988) is famous for his short, but widely quoted definition of quality: "fitness for use". The reasoning behind this definition was that the quality of a product or service is acceptable if it is tuned to the expected use.

Two conditions must be met to actualize this objective. One, the product or service must comply with the agreed specifications. Two, they must be free of failures. Bisgaard (2008) suggests labeling these two aspects "design quality" and "delivery quality". Such an extension is in tune with current interest in service quality, and are undoubtedly very useful in relation to information products. Nevertheless, one must remember that there is many a slip between cup and lip. That is, there are many steps between the design of information products and their delivery. Such as developing, implementing and managing the system. These three additional steps will also be addressed in this article from the perspective of getting useful accounting information to managers and other stakeholders.

Information

According to many authors (e.g., Hirschheim et al. 1995; Zins, 2007), the most fundamental concepts related to information systems are data, information and knowledge. The data are considered to be the basic materials, which have to be refined into information that will expand and enhance our knowledge. Kettinger and Li (2010) assert that this hierarchical approach from data via information to knowledge is the most common approach in the area of informatics. Data are descriptions of relevant objects or events. Information is processed data (e.g., classified, summarized or transferred) and is meant to add meaning and value within a specific context. Knowledge is actually a higher evolved and valued form of information. Something further up the food chain. It is information derived from a specific context - or contexts - that can be generalized and applied to other contexts. According to Davenport and Prusak (1998), data usually refer to facts about objects or events, information is processed data or a message that makes a difference or informs, and knowledge is framed experience used to evaluate or incorporate new experiences.

A somewhat different, but equally interesting view is presented by Langefors (1980), who developed the interactive model: $I = i(D, S, t)$. In this model information (I) equals interpretation (i) of data (D) based on the previous knowledge of the receiver or the receiving structure (S), during a specific time amount of time t. You could say that the value of information is context-dependent.

Accounting information

Romney & Steinbart (2009, 28) define an accounting information system as one that "collects, records, stores, and processes data to produce information for decision makers". Consequently, one may infer that it is information specifically geared for decision makers. They further specify (p. 29) that this information is meant to be "useful for decision making so that management can plan, execute, control, and evaluate activities, resources, and personnel". These are general management activities and, therefore, these authors seem to regard accounting information as equivalent to management information.

Maines and Wahlen (2006, 401), on the other hand, define accounting information as "a representation of economic constructs that are embodied in a firm's commercial arrangements, transactions, and events that yield a firm's future cash flows". This means that accounting information is not only management information, but also information that is reported in internal and external financial statements. Therefore, it may be useful to restrict the concept of accounting information to information derived from financial information systems that are linked to the general ledger. The information from ERP systems will generally comply with this requirement.

Thus let's say that accounting information is information linked to accounting systems, which is used internally to inform managers as well as externally to provide necessary financial information to stakeholders.

III Quality of information

In this section some well-known models or other observations related to information quality or information systems success are presented in order to examine how "fit for use" these models are with regard to accounting information as defined in section II.

The Shannon-Weaver model

The first well-known model for information quality was the Shannon-Weaver model (1949). This model shows that a message from the information source is transformed into a digital signal by means of encoding. The signal will then be transported through a communication channel. The received signal is decoded by the receiver and when everything goes well the intended message gets through to the intended receiver. This model was focused on an important communication problem in those days. Namely, that of noise in the communication channel. The needed capacity of the channel could be calculated when the amount of noise was known. The noise could be compensated for by redundancy in the form of an error correction code in the signal (Shannon 1948).

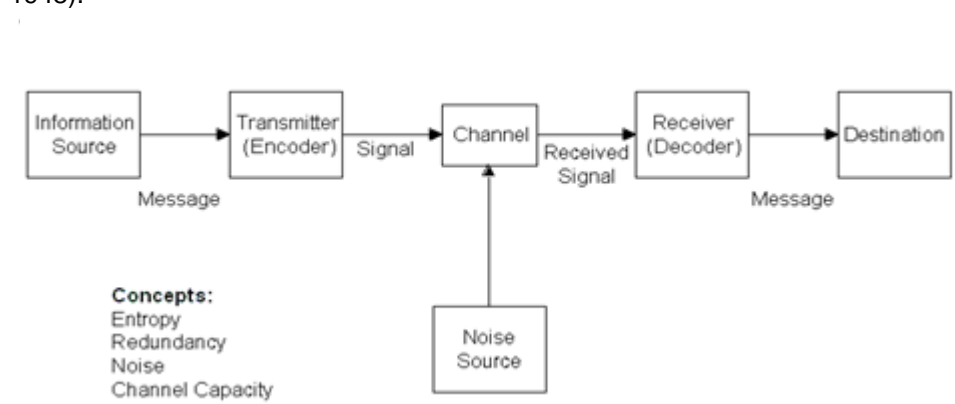

Figure 1, the Shannon-Weaver Model (1949)

Later on, Shannon (1956) discussed the effects of feedback from the designated receivers about the capacity of the channels. However, Shannon and Weaver (1949) were not interested in the meaning or semantics of the message. "The fundamental problem of communication is that of reproducing at one point either exactly or approximately the message selected at another point. Frequently [,] messages have meaning [but] these semantic aspects of communication are irrelevant to the engineering problem" (ibid., p. 3). From our point of view, this makes the Shannon-Weaver model less interesting.

Semiotics

In contrast with Shannon and Weaver, semiotics (also known as semiology) is less focused on the technical aspects of data communication and more on the content or meaning of messages. This theory of signs or signals is based on ancient Greek philosophy (Corning 2007).¹ Umberto Eco, the well-known Italian philosopher and bestseller author, is commonly regarded as the European mentor of modern semiotics (Baron 2005). Originally, the theory was part of the subject of logic. But via linguistics it has wormed its way into information science.

One of the most interesting contributions of semiotics to informatics was Morris' (1955) division of signals into three levels (with decreasing levels of abstraction).

1. The pragmatic level: the origin, use and effect of signals.
2. The semantic level: the content or meaning of signals.
3. The syntactic level: the structure of signs without reference to meaning, effects or source.

The interpretation of signals may differ from the intentions of the sender. This is a semantic problem. According to Eco (1976), the interpretation of signals depends on the cultural, ideological and personal implications of the signal. Chandler (2007) points at the importance of the experience of receivers and the conventions to which they are conditioned in on how signals are interpreted.

This agrees to some extent with the vision of Langefors (1980) who defined information as the interpretation of messages based on the previous knowledge of receivers or the receiving structures. In any case, it is clear that the interpretation of messages depends on context. Stamper et al. (2000) argue that in an organizational context the meaning of a message is influenced by the rules of the organization. Such messages can only be understood if the rules are known. These authors conclude that a semantic model of the organization is needed as a basis for a functional design of information systems.

The success model of DeLone and McLean

According to the model of DeLone and McLean (1992, see Figure 2), the success of information systems depends on both system- and information-quality. They argue that an information system is successful if it is used and valued by the users, has an influence on individual users and effects on the organization. In other words, it is mainly the pragmatics of the information that are considered. If the definition of quality ("fitness-for-use") by Juran (1988) is still relevant, then quality can indeed be measured by the rate of usage, satisfaction of users and impact on organizations. DeLone and McLean (1992, 87-88) suggest combining both measures of success into a comprehensive instrument.

¹ Both words stem from the ancient Greek word for sign "sema" (σήμα).

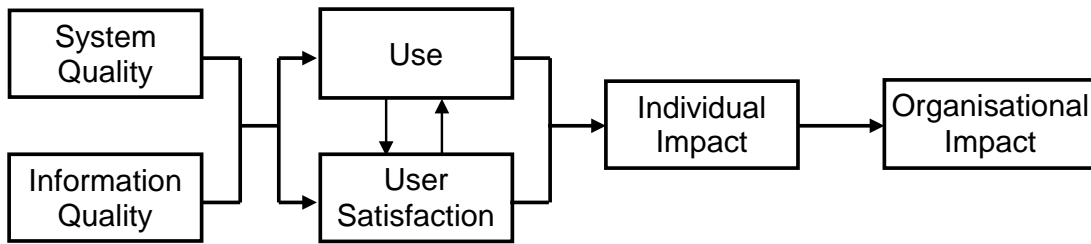

Figure 2, Original IS Success Model by DeLone & McLean (1992)

Further down the line, the same authors published a new IS Success Model (2003). In this model the quality of sustaining services is included as a new predictor variable.² What's more, the purpose of quality has become to create "net benefits" for organizations. In other words, the information system has to add value to organizations. This is determined by their intended use of system and the satisfaction it creates among users. The model shows a feedback loop from net benefits to use and satisfaction. Apparently, users will make more use of the system and be more satisfied when they know that the information creates value.

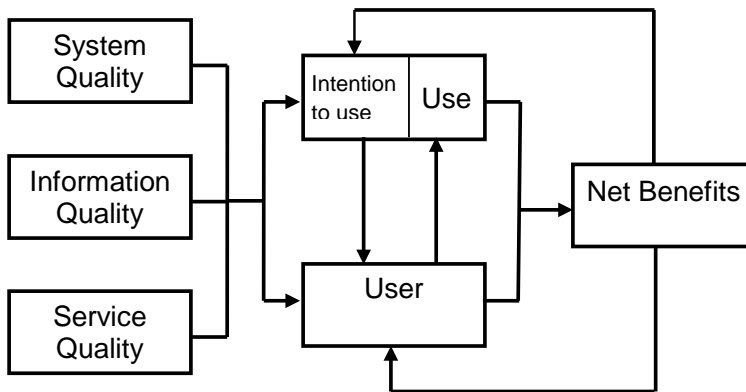

Figure 3, Adapted IS Success Model by DeLone & McLean (2003)

Quality characteristics of information

Nelson, Todd and Wixom (2005) have used the first success model of De Lone and McLean (1992) to specify the characteristics that apparently determine system- and information-quality. A literature review revealed four important characteristics of information quality. Namely, accuracy, completeness, currency and format. Accuracy of information is generally defined as the degree to which the reality is represented by the information. Completeness refers to the presentation of all relevant states relevant to the user. Nelson et al. (ibid., p. 203) point at the contextual aspect of this definition. The information may be complete for one user, but incomplete for another. Currency refers to the timeliness of the information. This is also a contextual concept. Format refers to the representational quality of the information.

Additionally, Nelson et al. (ibid., p. 205) identified the most discussed characteristics of system quality. Namely, accessibility, reliability, response time, flexibility and integrity. Accessibility refers to the ease of access to the data by the user. Reliability refers to the dependability of the system.

² Service quality can be an important quality factor, because it influences the perceptions of the users about information quality. However, regarding accounting information it seems to be of less interest. That is why we don't further address this characteristic in this article.

This can be measured in uptime of the system. Response time refers to the time it takes before a desired action is executed by the system. Flexibility refers to the ease of adapting the system and integration to how information from different sources has been pulled together.

Nelson et al. (2005) have investigated these quality characteristics for users by means of a survey study including 465 users of data warehouses. This investigation showed that accuracy is by far the most important information quality characteristic, followed at a significant distance by completeness. Reliability appeared to be the most important characteristic of system quality, followed by accessibility. The limitation to data warehouse users is a constraint in this investigation. One may expect that users of ERP systems pay more attention to, say, currency and the response time of the system. However, accounting information is generally ex-post information, which will share most of the characteristics of the information from data warehouses.

The Accounting Information Framework

In Section II we concluded that accounting information is information linked to accounting systems and is used internally to inform managers and externally to provide the required financial information to stakeholders. Maines and Wahlen (2006) focus on the information to stakeholders and define accounting information in this way: "a representation of economic constructs that are embodied in a firm's commercial arrangements, transactions, and events that yield a firm's future cash flows" (ibid. p. 401). This approach is shown in Figure 4.

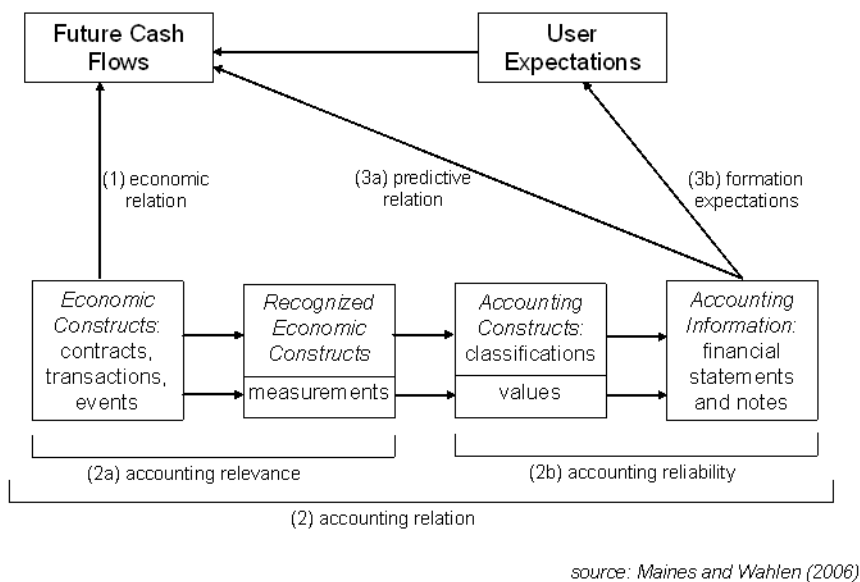

Figure 4, Accounting Information Framework by Maines and Wahlen (2006)

In this figure two important quality characteristics of accounting information are presented: namely accounting-relevance and -reliability. Accounting relevance relates to the recognition of relevant economic constructs. That is, the objects about which information is collected and the measurements of that information. Accounting reliability relates to the classification and selection of accounting information to be presented in financial statements.

The quality characteristic "relevance" has not yet been directly addressed in this article. However, it can be argued that it resembles completeness of information. Batini et al. (2009, 16-17) define

completeness as: "the degree to which a given data collection includes data describing the corresponding set of real-world objects". The real world objects in the case of accounting information are such economic constructs as contracts, transactions, and events. However, different perceptions of reality are possible. Nelson et al. (2005) stress that completeness only can be assessed relative to the contextual demands of users. In other words, completeness cannot be objectively assessed. That makes this concept comparable with relevance.

The accounting reliability of Maines and Wahlen (2006) is called faithful representation by the International Accounting Standards Board (IASB, 2010). In order to be faithful, the representation should be complete, neutral and free from error. The concept of completeness was discussed above. A convergence with the concept of relevance was noted. Neutral information means that the information is free from bias. Preparers' incentives may lead to misrepresentation of accounting information to their own benefit. This is a special issue related to accounting information and financial auditing. Maines and Wahlen (2005) thoroughly discuss this issue. It is part of the subject of financial reporting and is generally not addressed in the AIS literature³. Accounting information will be partially based on estimates that are inherently subjective.

However, in this article accounting information will be treated as the routine information from accounting information systems. Therefore, the matter of subjectivity of accounting information can be disregarded. Then the concept of faithfulness will - to a large extent - converge with accuracy and completeness.

IV Control of the quality of accounting information

In this section we will explore how the prevailing quality characteristics of accounting information can be controlled. The basis for this analysis are the quality characteristics that appeared to be the most important according to the survey study by Nelson et al. (2005) namely, accuracy, completeness, reliability and accessibility. However, the definition of these characteristics will be slightly adapted to make them useful for accounting information.

Accuracy will be defined as the degree to which information is a representation of events and objects in the real world. Completeness will be defined as the degree to which relevant events and objects in the real world are represented by the information. Reliability will be defined as the degree to which systems are protected against failure, manipulation and unauthorized intrusion. Accessibility will be defined as the degree to which systems and the information stored in them are available to users.

Control of the accuracy of accounting information

According to semiotics, the accuracy of information can be divided into syntactic and semantic correctness. The syntactic variety refers to how the information conforms to formal requirements for coding and format. The semantic is more in line with our definition of accuracy. That is, the degree to which the information truly represents events and objects in the real world. To promote the semantic correctness of information the functional model of the information system must fit into the real world context. According to Stamper et al. (2000), it must fit into the business rules of the organization being studied. They claim that this requirement can be supported by using a semantic model of the organization as a basis for the functional model of the information system. The semantic model may take the shape of a graphic representation of the business processes.

In the framework for data governance developed by Khatri and Brown (2010), metadata ("data about data") is one of the five⁴ decision domains identified. They claim that a valid description of data types may help to interpret the semantics of data. A good description of the data - also

³ Although there may also be biases in internal information, like performance measurements, we will ignore this issue in this article.

⁴ The other decision domains identified by these authors are: data principles, data quality, data access en data lifecycle.

called "data repository" or "data dictionary" - is surely an important measure to support the right interpretation of data, but it is still more important that the data model is constructed in a sensible way. In order to improve the semantic quality of the data model, it is necessary that it be a good representation of the business processes, i.e., the frame of reference for accounting information (De Koning, 2003).

Figure 5 shows a graphic representation of the main information flows in a trading company. These flows have to be measured at various points and recorded in the database. The recording in the database is performed by applications. One of the tasks of these applications is to validate the data input. This includes a syntactic control of the data, i.e., a controlling the format of the data⁵. Additionally, the codes or values entered can be checked for consistency against codes or values in tables.

Information flows of trading company

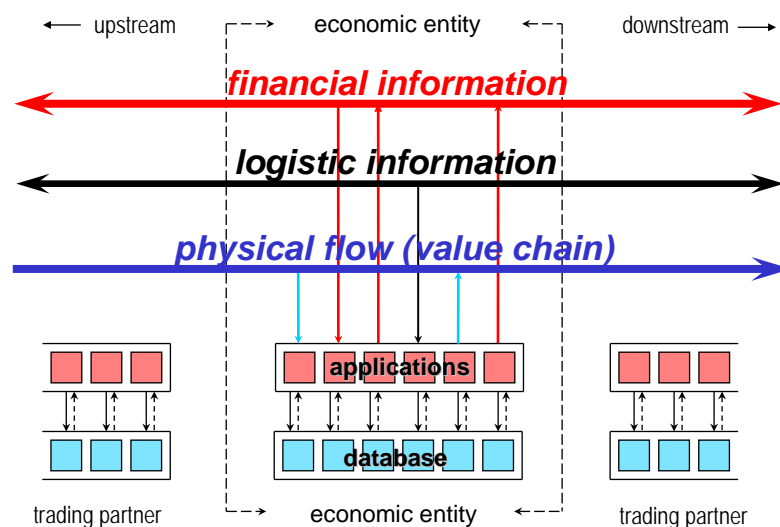

Figure 5, Model for accounting information (De Koning, 2003)

In some cases the applications may even execute controls on semantic correctness. For example, three way matching: an automatic control on the consistency between orders entered, recorded receipts of goods, and invoices booked (see: Kuhn and Sutton, 2009). Such an application control is available in many ERP packages⁶. Semantic controls can also be partially executed by means of the output from the system, most notably management information. Finally, the relations within the (relational) database can offer a certain safeguard that consistency of data is protected.

Control of the completeness of accounting information

The completeness of information has to be primarily safeguarded at the design level of the information system. The data model of the corporate data base must be a true reflection of the

⁵ This syntactic control may also be executed by the Database Management System (DBMS) by means of the values that are entered into the data dictionary (see De Koning, 2003, p. 94).

⁶ Note that this facility usually has to be activated during implementation of the package.

relevant business processes. These processes, mainly the three information flows depicted in Figure 4, have to be recorded in the system. That system (in fact, the applications) must then control the consistency of these flows. The three way matching just mentioned is an example of a feature designed to control of the consistency of the different information flows as shown in Figure 4. Further, from the accounting perspective a comparable control is important on the sales side of information flows. That is, the consistency check on sales orders, goods delivered and invoices booked.

Control of the reliability of the software

The reliability of the software plays an important role in the accuracy and completeness of accounting information. The applications have to be tuned to the needs of users and match up with business processes. Based on empirical research, Hong and Kim (2002) claim that the organizational fit is the most important success factor related to the implementation of ERP systems. According to them, this consists of:

- process fit (alignment of software and business processes);
- data fit (alignment of data model and the relevant data to the organization);
- and user interface fit (alignment of user-interface and -needs).

Comparable results were found by means of a case study (De Koning, 2006), which indicated that the most important success factor was what was called the functional fit. That is, the alignment of business processes and the functionality of its software (= process fit). This requires a data model that is a good reflection of the business processes (= data fit). This should be kept in mind during the selection and acquisition phase of an ERP package.

In cases of tailor made software it is important that the systems development methodology offers safeguards for a good match of the application software with the business processes. Modern development methodologies, such as RUP, which proposes an iterative and incremental approach (Krugten, 2003), and so-called agile methods, which are more oriented toward cooperation and communication than traditional methods, may support such a matching (Nerur and Balijepally, 2007). These methods are more flexible and more oriented towards investigation and learning. However, this may infringe upon the controllability of the systems development project. Therefore, special attention should be paid to controlling the project and the quality of the software delivered. Subramanian et al. (2009) propose performing a goal-oriented control instead of the task-oriented control that was usual in the traditional systems development methodologies. They claim an important role for communication and informal controls (the so-called soft controls). According to them, the quality and progress of the systems development can be monitored by means of feedback cycles, which are comparable with the phases of the traditional methods. Moreover, extensive testing is required after each development cycle.

Testing software is still a difficult and time-consuming activity. Nevertheless, it is essential for the reliability of software. It takes place during different phases of the development process, including the coding of modules, the integration of modules into systems and the acceptance by users and system operators. During recent years many techniques have been developed to make testing more efficient and effective, such as simulation (Armour, 2005), test data generation (Sofokleous and Andreou, 2008), risk driven testing (Schneidewind, 2007), and adaptive testing (Cai et al., 2008). However, testing can never replace sensible systems development and feedback, such as code inspection (Armour, 2005).

The management of changes in the application software also plays an important role in their reliability. This is as true for tailor made software as it is for standard software packages. The changes have to be logged, reviewed, tested and authorized before the software is made operational. This prevents changes from undermining the stability or integrity of the operational software (ITGI 2007, p.93-99). Additionally, ITIL presents guidelines for change management being part of the "service transition stage" (ITSMF 2007). Certifying accountants endorse the importance of the management of changes in application software. Auditing Standard No. 5 of the

Public Company Accounting Oversight Board (2007), a guideline for accountants who audit public companies in the US, states in paragraph B29 that the accountant may rely on the effectiveness of application controls, provided that change management, access control and other control procedures are functioning well and it has been ascertained that the application controls have not changed. In those cases it is not necessary to test the application controls again.

Control of the reliability of data processing

Nelson et al. (2005) found that reliability is the most important quality characteristic of information systems. They focused on the availability of the system and recovery from failures and disruptions. Protecting the system from unauthorized access and data manipulation is also important. Security measures against these infringements form part of the general IT controls, which are specified as:

- data center operation controls
- system software controls
- access security controls
- application development and maintenance controls⁷

An important part of the general IT controls are those related to continuity of the data processing, including duplication of hardware and data files. The ITIL best practices (Van Bon and Van der Veen, 2007) also offer opportunities to optimize the general IT controls. ITIL Version 3 presents best practices for IT related processes, including service design. From the perspective of data processing reliability, the most important modules of the service design phase are: IT Service Continuity Management and IT Security Management. ITIL Version 3 has a more conceptual approach than the former more pragmatic edition and, therefore, better supports the alignment of IT with the needs of users.

The logical access control can be divided into controls on the system level, including the protection of data communication facilities, and controls on the application level. The latter is necessary to create functional separation of duties, especially by means of authorization of the access to special functions of the software (authorization controls).

Control of the accessibility of the data processing

Accessibility is defined as the degree to which systems and the information stored in them are available to users. ITIL Version 3 can be used to achieve this quality aspect. Its Capacity Management- and Availability Management- modules are especially designed to support accessibility.

ITIL Version 3's Risk Management module supports both reliability and accessibility of computer systems. Risk management was already operational in IT environments years before Enterprise Risk Management (ERM) became popular. It was mainly used to assess and analyze risks and evaluate possible countermeasures (see e.g., De Koning, 1995). The US National Bureau of Standards (1979) made useful recommendations to weigh quantified risks against the costs of possible control measures. To further this aim the concept "annual loss expectancy" was introduced. That is the product of the yearly occurrence of risk and its impacts. In principle, the costs of the counter measures should not exceed the annual loss expectancy. In this way a sensible cost/benefit can be made. Thanks to the ongoing decline of the costs of hardware and data communication, new solutions - such as duplication of databases and hardware - become within reach of many organizations.

V The conceptual framework

In this article accounting information has been defined as information linked to accounting systems, which is used internally to inform managers as well as externally to provide necessary

⁷ IT Governance Institute, 2006, p. 29

financial information to stakeholders. We did not address the subject of biased information, as did Maines and Wahlen (2006). The scope of this article is confined to routine information from regular information systems.

To be able to speak of qualitative good accounting information, this information must meet the agreed specifications and be free of error. The foundation of these requirements is laid during the design, development, implementation and management of systems that deliver accounting information. DeLone and McLean (1992) make a distinction in their success model between information quality and systems quality.

Nelson, Todd and Wixom (2005) showed by empirical research that accuracy and completeness of information have to be considered as the most important characteristics of information quality. Further, reliability and accessibility are the most important characteristics of system quality.

However, the IASB (2010) considers relevance and faithful representation to be the most important quality characteristics. We argued that faithful representation coincide with accuracy. Relevance overlaps with the concept of completeness. That means that the quality characteristics distinguished by Nelson et al. (2005) can also be applied to accounting information, although the definitions may need to be slightly adapted. Semiotics teaches us that the accuracy and completeness of information is context-dependable.

Stamper et al. (2000) point at the fact that business information can only be understood if it fits into the rules of the organization. In other words, if the semantic accuracy of information prevails. They argue that a semantic model must be the basis of the systems' design. De Koning (2003) argues, that the data model - i.e., the design of the corporate database of a company - has to be a good representation of the physical, logistic and financial processes of the organization. The data model should reflect these processes and the steps that are taken as part of these processes. The systems design should be based on the data model and support procedures to test the consistency of data flows.

Modern system development methodologies, such as RUP or agile methods, are useful to facilitate the interaction between business requirements and technical solutions, and thus support semantic correctness. However, these methods underestimate control issues. That needs to be compensated for by additional measures, such as inspection of program codes, testing and change management.

Organizations making use of such standard software systems as ERP do not have the opportunity to develop adequate data models. However, they may use this concept to assess the suitability of their standard software to their needs. That is, by comparing the data model and functionality of these systems with their business processes, preferably laid out in a semantic model.

The automatic reconciliation of the input and output of the successive phases of the business processes is an important factor in safeguarding semantic correctness and the completeness of accounting information. Additionally, separation of duties concerning the business processes can be supported by authorization controls.

The syntactic accuracy of accounting information can be secured by input validation in applications and facilities to support data integrity in database management systems. The reliability of application software can be secured by a good development methodology and the additional control measures mentioned above.

To support these quality characteristics of accounting information, the reliability and accessibility of the information systems must be secured. This requires duplication of data and supporting hardware, access controls to the information systems, authorization controls to users, and security-, capacity- and availability-management. To support security- and continuity-management risk management can play a useful role.

Access- and authorization-controls are useful in protecting accounting data from unauthorized access and manipulation. Additionally, authorization controls may support the required separation of duties regarding business processes and the input of data to carry out these processes.

All relevant types of control measures to secure the information- and system-quality are summarized in Table 1.

| Quality aspects | | Controls | | |
|---|-------------------------------|--------------------------------|-----------------------------|-------------------------------------|
| <i>According to Nelson, Todd & Wixom.</i> | <i>Further specification</i> | <i>Data-oriented</i> | <i>Application-oriented</i> | <i>General controls</i> |
| Accuracy | Semantic | data model | systems design | development meth. |
| | Syntactic | repository | edit & validation | NA ⁸ |
| | Reliability software | NA | testing | development meth. change management |
| Completeness | Consistency information flows | referential integrity | application controls | logical access control |
| Reliability | Continuity | duplication of data or systems | NA. | continuity management |
| | Protection of data | access controls | authorization controls | security management |
| Accessibility | Access to data | NA | NA. | capacity management |
| | Availability of data | NA | NA. | availability and risk management |

Table 1: Quality aspects and matching controls

Table 1 presents global indications where the controls to safeguard the related quality characteristic may be found. These are the subjects that primarily qualify for further research. This further research can be focused on the analysis and elucidation of the control measures and subsequently the empirical validation of the presumed effect of the controls. Finally, the whole table can be verified in this way.

VI Conclusions en recommendations

Main conclusions

This aim of this article was to present a conceptual framework for the quality of accounting information. In order to do so, an analysis was made to find the desirable quality characteristics of accounting information and the control measures that have to be taken to secure them. Based on this analysis some notable conclusions can be drawn. The most important characteristics of information quality appear to be accuracy and completeness. The concept of accuracy has a great resemblance to the concept of faithful representation used by the IASB (2010).

Further, semiotics teaches us that the semantics of information is context-dependent. The literature on data quality tends to underestimate the importance of this aspect. That means that the research on the quality of accounting information has to pay more attention to the factors that

⁸ NA = Not Applicable

influence the semantic correctness of that information. For example, the data model, the functional systems design and the systems development methodology.

Additionally, the analysis shows the importance of logical access control and user authorization to both secure systems against unauthorized access and data manipulation and achieve the desired separation of duties by means of the information system. This may also secure to a large extent the completeness of accounting information.

Finally, it shows that the best practices of ITIL can play an important role in realizing adequate general controls to ensure systems quality. Notably, the reliability and accessibility of the information systems. A good organization of the operations around the data processing provides a firm foundation for good system quality.

The analysis provides insight into the most interesting subjects for further research. Further research can take place in the form of case studies or surveys. In this way the framework presented in the previous section may be validated. However, one of the problems of empirical research on quality of information is the subjective nature of the results. Most empirical findings will be based on the perceptions of respondents, who may have some bias in favor of solutions used by themselves or their organization. To avoid this bias research on failing quality characteristics (as shown by e.g. restatements) and their causes may be chosen as a starting point. A fine example of this type of research is the research of Morris (2011), who demonstrated that companies that use ERP-systems tend to present less internal control weaknesses than companies that do not use ERP-systems. Such research shows the effects of application controls that are inherent in ERP-systems.

Limitations

This article is partially based on the empirical research of Nelson et al. (2005). Their investigation was aimed at users of data warehouses. Generally, accounting information is not derived from data warehouses, but from operational systems like ERP. Users of ERP may have requirements other than users of data warehouses. However, accounting information shares many of the characteristics of information from data warehouses, since most of the accounting information is ex-post. That is, requirements like response rate and currency will play a less important role. Further, the definitions of the most important quality characteristics by Nelson et al. (2005) have been slightly adapted to the characteristics of accounting information. We do not think this affects their conclusions.

The control measures presented in this article are linked to quality characteristics on theoretical grounds, based on an extensive search of the literature. Nevertheless, the measures chosen might show a subjective preference. Further research is needed to support the framework presented in 5.1.

Suggestions for further research

At the moment empirical research on the effects of the systems design and different methods for systems development on the quality of accounting information is lacking. This could be an interesting research area, that may enhance design and development practices. Many research is already done on data modeling, especially REA-models⁹. Design science research methodology offers additional opportunities in this area (Geerts, 2011). Moreover, the REA model may be used for alternative purposes. O'Leary (2004) noticed the resemblance between the REA-model and the design of a well-known ERP package. Further research might reveal the usability of data modeling during the selection process of ERP software. Especially, a match between the specific REA-model for an organization and the data model on which an ERP package is based will show the applicability of such an ERP package. The effect of ERP systems - or application controls in

⁹ REA-models are data models that emphasise three types of data representing: (1) resources, (2) events and (3) agents

general - on the quality of information is also an interesting subject for further research, as is the effect of authorization controls on the reliability of accounting information.

Finally, more research could be done into the relationship between general controls and the quality of accounting information. Nowadays many medium sized and small organizations make use of sophisticated application packages, but fail to satisfy the generally accepted criteria for adequate general controls. One interesting question is whether they have to change their practices or the criteria themselves have to be adapted to real life situations.

References:

- Abbott, L. 1955. *Quality and competition*. New York, NY: Columbia University Press.
- Armour, Ph.G. 2005. The Unconscious Art of Software Testing. *Communications of the ACM* 48 (1): 15-18.
- Baron, N.S. 2005. Who Wants to Be a Discipline? *The Information Society* 21 (4): 269–271.
- Batini, C., Cappiello, C., Francalanci, Ch. and A. Maurino. 2009. Methodologies for data quality assessment and improvement. *ACM Computing Surveys* 41 (3): 1-52.
- Bisgaard, S. 2008. Quality Management and Juran's Legacy. *Quality Engineering* 20 (4): 390–401.
- Bon, J. van, and A. van der Veen. 2007. *Foundations of ITIL® V3*. Zaltbommel, NL: Van Haren Publishing. http://www.itsmfbooks.com/foundations_itil_english_version-p201.html
- Cai, K.-Y., Chen, T.Y., Li, Y.-C. and Y.T. Yu. 2008. On the Online Parameter Estimation Problem in Adaptive Software Testing. *International Journal of Software Engineering & Knowledge Engineering* 18 (3): 357-381.
- Chandler, D. 2007. *Semiotics, the Basics* (2nd edition). London, UK: Routledge.
- Corning, P.A. 2007. Control Information Theory: The 'Missing Link' in the Science of Cybernetics. *Systems Research and Behavioral Science* 24: 297-311.
- Crosby, P. B. 1979. *Quality is free: The art of making quality certain*. New York, NY: New American Library.
- Davenport, Th. and L. Prusak. 1998. *Working Knowledge: How Organizations Manage What They Know*. Boston, Ma: Harvard Business School Press.
- DeLone, W.H. and E.R. McLean. 1992. Information systems success: The quest for the dependent variable. *Information Systems Research* 3 (1): 60-95.
- DeLone, W.H. and E.R. McLean. 2003. The DeLone and McLean Model of Information Systems Success: A Ten-Year Update. *Journal of Management Information Systems* 19 (4): 9-30.
- Eco, U. 1976. *A Theory of Semiotics*. Bloomington, In: University Press.
- Feigenbaum, A. 1991. *Total quality control: Fortieth anniversary edition*. New York, NY: McGraw-Hill.
- Geerts, G.L. 2011. A design science research methodology and its application to accounting information systems research. *International Journal of Accounting Information Systems* 12 (2): 142–151.
- Gilmore, H. L. 1974. Product conformance cost. *Quality progress* 7 (5): 16-19.
- Hirschheim, R.A., Klein, H.K. and K. Lyytinen. 1995. *Information Systems Development and Data Modelling*. New York, NY: Cambridge University Press.
- Hong, K.-K. and Y.-G. Kim. 2002. The critical success factors for ERP implementation: an organizational fit perspective. *Information & Management* 40: 25-40.
- International Accounting Standards Board (IASB). 2010. *Conceptual Framework for Financial Reporting*. London, UK.
- International Organization for Standardization (ISO). 2005. *ISO 9000:2005: Quality management systems -- Fundamentals and vocabulary*. http://www.iso.org/iso/catalogue_detail.htm?csnumber=42180/
- IT Governance Institute (ITGI). 2006. *IT Control Objectives for Sarbanes-Oxley*. <http://www.isaca.org/Knowledge-Center/cobit/Documents/ITCO-Sarbanes-OxleyResearch.pdf?Token=80D0D764-621F-464F-AE3B-78864CF66AB1/>

- IT Governance Institute (ITGI). 2007. *CobiT 4.1*. <http://www.isaca.org/Knowledge-Center/COBIT/Pages/Overview.aspx/>
- IT Service Management Forum (ITSMF). 2007. *An introductory overview of ITIL® V3*. <http://www.itsmfi.org/content/publications/>
- Juran, J.M. 1988. The quality function. In *Juran's Quality Control Handbook* (4th ed., pp. 2.1-2.13), edited by J.M. Juran and J.M. Gryna. New York, NY: McGraw-Hill.
- Kettinger, W.J. and Y. Li. 2010. The infological equation extended: towards conceptual clarity in the relationship between data, information and knowledge. *European Journal of Information Systems* 19 (4): 409-421.
- Khatri, V. and C.V. Brown. 2010. Designing Data Governance. *Communications of the ACM* 53 (1): 148-152.
- Koning, W.F. de. 1995. A methodology for the design of security plans. *Computers & Security* 14 (7): 633-643.
- Koning, W.F. de. 2003. Application controls in a client/server Environment. In *Integrity and Internal Control in Information Systems V* (pp. 77-79), edited by M. Gertz. Boston, Ma: Kluwer Academic Publishers.
- Koning, W.F. de. 2006. *The Main Cause of Problematic ERP Implementations: Bad Management or Functional Mismatches?* Working paper. Available at SSRN: <http://ssrn.com/abstract=1676948>.
- Kuhn, J.R. Jr. and S.G. Sutton. 2010. Continuous Auditing in ERP System Environments: The Current State and Future Directions. *Journal of Information Systems* 24 (1): 91-112.
- Kruchten, P. 2003. *The rational unified process: An introduction* (3rd Edition). Boston, Ma: Addison-Wesley.
- Langefors, B. 1980. Infological models and information user views. *Information Systems* 5 (1): 17-32.
- Leary, D.E. O'. 2004. On the relationship between REA and SAP. *International Journal of Accounting Information Systems* 5 (1): 65-81.
- Levitt, T. 1972. Production-line approach to service. *Harvard Business Review* 50 (5): 41-52.
- Maines, L. A. and J.M. Wahlen. 2006. The Nature of Accounting Information Reliability: Inferences from Archival and Experimental Research. *Accounting Horizons* 20 (4): 399-425.
- Morris, C. 1955. *Signs, Language, and Behavior*. New York, NY: G. Braziller.
- Morris, J.J. The Impact of Enterprise Resource Planning (ERP) Systems on the Effectiveness of Internal Controls over Financial Reporting. *Journal of Information Systems* 25 (1): 129-157.
- National Bureau of Standards (NBS). 1979. *Guideline for Automatic Data Processing Risk Analysis, FIPS PUB 65*. Washington DC: U.S. General Printing Office.
- Nelson, R.R., Todd, P.A. and B.H. Wixom. 2005. Antecedents of Information and System Quality: An Empirical Examination Within the Context of Data Warehousing. *Journal of Management Information Systems* 21 (4): 199-235.
- Nerur, S. and V. Balijepally. 2007. Theoretical Reflections on Agile Development Methodologies. *Communications of the ACM* 50 (3): 79-83.
- Public Company Accounting Oversight Board (PCAOB). (2007). *Auditing Standard no. 5: An Audit of Internal Control Over Financial Reporting That Is Integrated with An Audit of Financial Statements*. <http://pcaobus.org/Standards/Auditing/Pages/default.aspx/>
- Romney, M.B. and P.J. Steinbart. 2009. *Accounting Information Systems* (11th edition) , Upper Saddle River, NJ: Pearson Prentice Hall.

- Schneidewind, N.F. 2007. Risk-driven Software Testing and Reliability. *International Journal of Reliability, Quality and Safety Engineering* 14 (2): 99-132.
- Shannon, C.E. 1948. A mathematical theory of communication. *Bell System Technical Journal* 27: 379-423 and 623-656.
- Shannon, C.E. and W. Weaver. 1949. *The Mathematical Theory of Communication*. Urbana II : University of Illinois Press.
- Shannon, C.E. 1956. The zero error capacity of a noisy channel. *IEEE Transactions on Information Theory* 2 (3): 8-19.
- Sofokleous, A.A. and A.S. Andreou. 2008. Automatic, evolutionary test data generation for dynamic software testing. *Journal of Systems and Software* 81 (11): 1883-1898.
- Stamper, R., Kecheng, L., Hafkamp M. and Y. Adesu. 2000. Understanding the roles of signs and norms in organizations - a semiotic approach to information systems design. *Behaviour & Information Technology* 19 (1): 15-27.
- Subramanian, G.H., Klein, G., Jiang, J. J. and C.-L. Chan. 2009. Balancing Four Factors in System Development Projects. *Communications of the ACM* 52 (10): 118-121.
- Zins, C. 2007. Knowledge map of information science. *Journal of the American Society for Information Science and Technology* 58 (4): 526–535.