

Contents lists available at [ScienceDirect](#)

## Kasetsart Journal of Social Sciences

journal homepage: <http://www.elsevier.com/locate/kjss>

## Structural equation model to assess the impact of learning organization and commitment on the performance of research organizations

Ardharn Khunsoonthornkit\*, Vinai Panjakajornsak

Administration and Management College, King Mongkut's Institute of Technology Ladkrabang, Bangkok 10520, Thailand

## ARTICLE INFO

## Article history:

Received 29 April 2016

Received in revised form 15 December 2016

Accepted 21 December 2016

Available online xxx

## Keywords:

learning organization,  
organizational commitment,  
organizational performance,  
research and development organizations

## ABSTRACT

This study analyzed the impact of learning organization and commitment on the performance of research and development organizations in Thailand. The research used a structural equation model based on an extensive review of relevant literature. The population and samples were drawn from full-time researchers in two science and technology organizations under the Thai Ministry of Science and Technology. A questionnaire survey was used to collect empirical data. The model fit was analyzed using the confirmatory factor analysis technique. The results showed that learning organization had a direct effect on organizational commitment and performance. However, commitment had no direct effect on organizational performance. Based on these results; scientific, and technology and development policy and planning should consider applying learning organization in research organizations.

© 2018 Kasetsart University. Publishing services by Elsevier B.V. This is an open access article under the CC BY-NC-ND license (<http://creativecommons.org/licenses/by-nc-nd/4.0/>).

## Introduction

Economic development and competitiveness in countries around the world are increasing. To secure comparative advantages, such as, technological competitiveness based on changing consumption, and integration into single markets, companies make decisions, operate their businesses, and create or invent new products and manufacturing processes based on scientific and technological research. They do this in response to the demands of consumers in order to maintain their business over the long term (Sudharatna & Hongladarom, 2006). Many countries focus on research and development, especially prosperous and stable countries. The highest percentage of GDP

allocated to research and development (34.90%) was reported in North America followed by countries in Asia, Europe, and Africa (32.20%, 27.40%, and 0.90% respectively) according to UNESCO Institute for Statistics (2011).

Thailand has a relatively low percentage (0.21–0.26%) of GDP spent on research and development (National Research Council of Thailand, 2012). One of the missions of the Ministry of Science and Technology of Thailand (MOST) is to propose scientific, technological, and innovative strategies and planning as well as social contribution that will increase productivity and the quality of life for Thai people. However, the government requires more advanced research and development processes in order to improve society and the country within its tight budget. Therefore, the establishment of learning organization is crucial as this approach allows organizations to develop in a systematic manner, strengthen workflow, and to be better equipped to cope with changes in the business environment such as market competition, innovation and changes

\* Corresponding author.

E-mail address: [khunsoonthorn196@hotmail.com](mailto:khunsoonthorn196@hotmail.com) (A. Khunsoonthornkit).  
Peer review under responsibility of Kasetsart University.<https://doi.org/10.1016/j.kjss.2018.07.003>2452-3151/© 2018 Kasetsart University. Publishing services by Elsevier B.V. This is an open access article under the CC BY-NC-ND license (<http://creativecommons.org/licenses/by-nc-nd/4.0/>).

Please cite this article in press as: Khunsoonthornkit, A., & Panjakajornsak, V., Structural equation model to assess the impact of learning organization and commitment on the performance of research organizations, Kasetsart Journal of Social Sciences (2018), <https://doi.org/10.1016/j.kjss.2018.07.003>

in technology, and the needs and requirements of stakeholders. This research used a structural equation model to study the impacts of learning organization and commitment on performance in two research and development organizations under MOST (the Thailand Institute of Scientific and Technological Research and the National Science and Technology Development Agency).

## Literature Review

A learning organization is an organization with the philosophy and resolution to create sustainable solutions and outcomes, as well as to integrate and exchange perspectives with partners in order to promote the organization. Its corporate culture is to build learning awareness and to develop according to the strategies of the organization as well as to assimilate and modernize the organization. According to the notions of [Watkins and Marsick \(1993, 1996\)](#), there are four levels of learning: individual, team, organization, and society. A learning organization is able to encourage personnel to assimilate based on mutual assimilation and vision. There are seven aspects of learning models: 1) continuous learning, 2) inquiry and dialog, 3) collaboration and teamwork, 4) empowerment of people, 5) creation of the system, 6) connection to the environment, and 7) strategic leadership.

According to [Meyer and Allen \(1991\)](#), commitment to an organization can be divided into three types: affective, normative, and continuance. This relationship with regard to an organization refers to believing and accepting the organization's aims, values, and effort to acknowledge personnel as representatives of the organization. The relationship involves feelings, mood, behavior, attitude, the need to be a member of the organization, and employment relationships.

Overall operation refers to the expected outcomes or determined activities. These need to be seen as valuable to the organization, and can effectively serve and provide solutions to problems in the community and society through the wise use of resources. Effective outcomes can be used as one criteria in evaluating success in building a learning organization. Organizational performance can be

considered in terms of mission, finances, knowledge, and innovation.

Based on the literature review, the framework for the study is illustrated in [Figure 1](#). The hypothesis is that being a learning organization has a direct effect on organizational performance and commitment, and that organizational commitment has a direct effect on organizational performance.

## Research Methodology

This study involved quantitative research. Secondary information was gathered from related concepts, theories, and the literature. Primary information was sourced using a close-ended questionnaire to gather the information from representative samples. The SPSS version 16 and AMOS software programs were used to interpret and assess the causal influences. [Schumacker and Lomax \(1996\)](#) suggested a method of setting appropriate representative samples, that is 10–20 samples per variable, depending on the complexity of the model. This study used one independent variable (learning organization) and two dependent variables (organizational commitment and performance). The factor variables consisted of seven, three and four observable variables, respectively, as shown in [Figure 1](#). Stratified sampling was used to access all information. The closed ended questionnaire was divided into four sections: 1) general information, 2) learning organization, 3) employee commitment, and 4) operating results. The questionnaire used seven levels for grading arranged in ascending order.

The population and samples of the study were full-time scientific and technology research and development personnel in two organizations working for the Ministry of Science and Technology: 1) the Thailand Institute of Scientific and Technological Research; and 2) the National Science and Technology Development Agency.

## Assessment of Research Tools

Five experts in learning organization and research and development strategies reviewed the questionnaire for content validity. The questionnaire was then adjusted

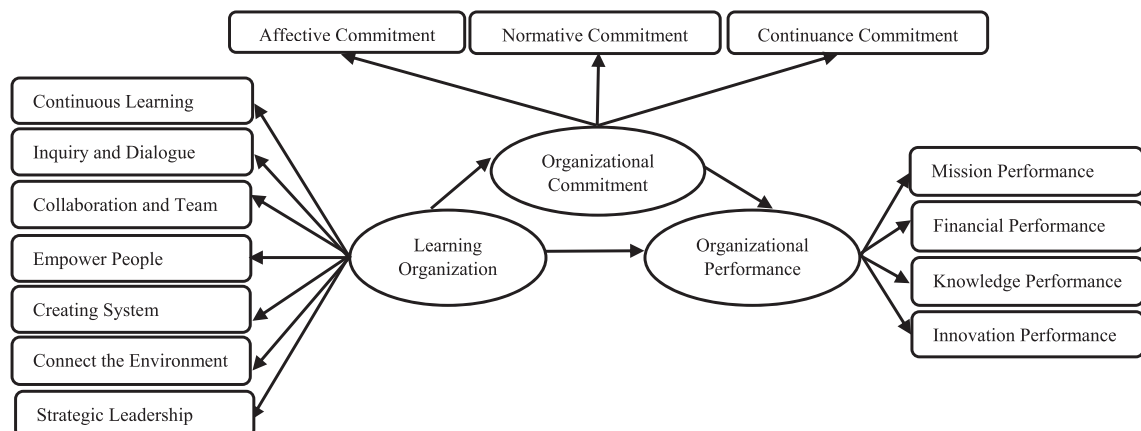

**Figure 1** Framework of the study

based on their comments before being distributed. Thirty pre-tests were administered and analyzed for reliability and internal consistency using coefficient alpha based on the Cronbach method which resulted in an acceptable value ( $\geq 0.7$ ). The results for reliability were 0.703–0.916 for operations, 0.725–0.918 for learning organization, and 0.740–0.887 for employee commitment.

#### Data Analysis

There were two parts to the data analysis: 1) analysis of general information of the representative samples through frequency distribution and percentage, and 2) analysis of the seven variables of a learning organization, the three variables of employee commitment, and the four variables of operating results or performance (see [Figure 1](#)). Hypothesis testing was carried out using confirmatory factor analysis (CFA) to measure the validity of the model fit to the empirical data. The hypothesis model and empirical data were tested using structural equation modeling (SEM) which can lead to path analysis in order to be able to test the model and hypothesis ([Wiratchai, 1999](#)).

## Results

#### Results of General Data Analysis

Data were collected from 361 research and development personnel. These samples included both male and female workers from every age group, education level, period of employment, position, and work experience. The results of the primary data analysis of the representative sample showed that the number of females 36–40 years with 6–10 years of work experience, and mostly holding master's degrees was greater than the number of males. Frequencies and percentages are shown in [Table 1](#).

#### Results of Hypothesis Testing

Regarding the research framework, the model of confirmatory factor analysis and analysis of the structural equation model is shown in [Figure 2](#). The result showed a good model fit with the empirical data within the expected level ([Table 2](#)).

In summary, the commitment model of the learning organization and employee commitment influenced the operating results of the research and development organization as hypothesized. As a result, the model used for measurement can be applied using structural equation model measurement to analyze future causal influence.

#### Analysis of Structural Equation Model

Causal commitment analysis indicated that the model of the learning organization positively and significantly influenced the operating result and commitment, with a standardized coefficient of 0.846 and 0.700, respectively, ( $p < .001$ ). The variables of the learning organization were able to account for 80.10 percent of the variance of the research and development organization variables ( $R^2 = 0.801$ ). Moreover, the variables of the learning

**Table 1**  
General data analysis

Description	Frequency	Percentage
Sex		
Male	132	36.6
Female	229	63.4
Age (years)		
20–25	9	2.5
26–30	48	13.3
31–35	67	18.6
36–40	79	21.9
41–45	71	19.7
46–50	39	10.8
51–55	25	6.9
56–60	23	6.4
Academic degree		
Doctoral degree	36	10.0
Master degree	190	52.6
Bachelor degree	120	33.2
Lower than bachelor degree	15	4.2
Position		
Chief executive	17	4.7
Middle level executive	42	11.6
Officer/Staff position	263	72.9
Temporary staff	39	10.8
Work experience (years)		
1–5	104	28.8
6–10	104	28.8
11–15	48	13.3
16–20	59	16.3
30 +	46	12.7

organization were able to describe 49.00 percent of the variance of the employee commitment variables ( $R^2 = 0.490$ ). On the contrary, the analysis of variables relating to employee commitment and operating results showed no significant statistic of influence.

The overall direct and indirect effects related to the learning organization of employee commitment influencing the operating results of research and development organizations are expressed in [Table 3](#).

The results from the learning organization model analysis show that employee commitment influenced the operating results of the research and development organizations as shown by the SEM below:

$$\text{Employee commitment} = (0.700 \times \text{LO}); R^2 = 0.490$$

$$\text{Operating results} = (0.894 \times \text{LO}) + (0.069 \times \text{OM}); R^2 = 0.801$$

## Discussion

#### Structural Equation Modeling of the Research Influencing Latent Variables

The main objective of the study was to investigate the impact of a learning organization and employee commitment on operating results using a structural equation model.

According to [Watkins and Marsick \(1993, 1996\)](#), a learning organization has a positive, direct, and significant influence on the operating results of research and development which conforms to the hypothesis of this study. In

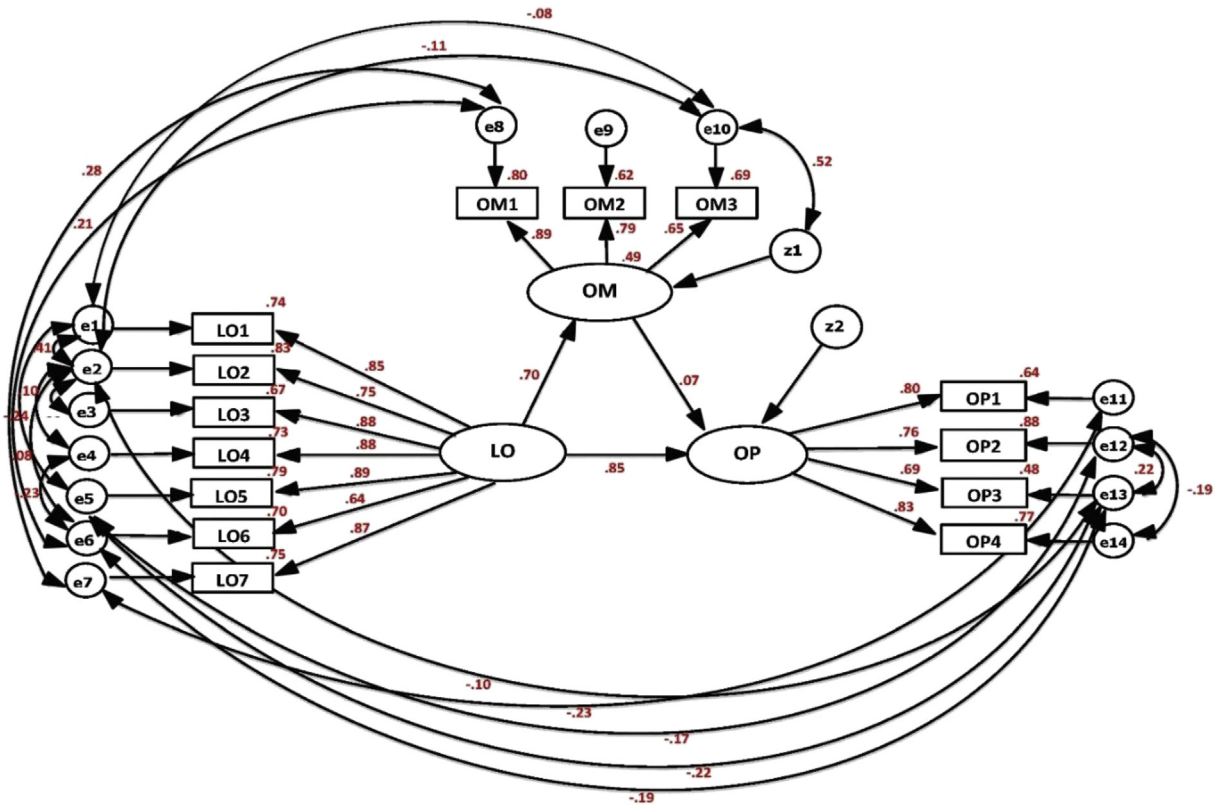

**Figure 2** Results of analysis of structural equation model of the learning organization (LO), employee commitment (OM), and operating results (OP).  
**Note:** LO = Learning organization, LO1 = Continuous learning, LO2 = Inquiry and dialog, LO3 = Collaboration and teamwork, LO4 = Empower people, LO5 = Creating system, LO6 = Connect to the environment, LO7 = Strategic leadership, OM = Organizational commitment, OM1 = Affective commitment, OM2 = Normative commitment, OM3 = Continuance commitment, OP = Organizational performance, OP1 = Mission performance, OP2 = Financial performance, OP3 = Knowledge performance, and OP4 = Innovation performance

addition, the hypothesis is consistent with the research of Alipour, Idris, Ismail, Uli, and Karimi (2011), Demers (2009), and Martinez (2009), who stated that a learning organization where personnel work together as a team can build learning naturally and can build commitment in learning by providing chances for questioning and discussing. The results of these studies explain the seven factors of a learning organization that influence research and development organization. If continuous learning is promoted to become organizational culture, the organization will be more effective (Herrera, 2007; Song, 2008). To drive a

research and development organization requires the integration of different fields and discussion in order to analyze the operating results to improve integration. This conforms to Senge and Joni (2005) who focused on the inquiry and dialog in smart teams that were able to make pre-decisions, find effective solutions, and accept new ideas for new innovation (Schein, 1993; Senge, Scharmer, Jaworski, & Flowers, 2004). Learning and accepting different ideas in a team can lead the team members to find solutions for complicated problems, and to build a continuous learning cycle through the organization (Senge, 1990). A research

**Table 2**  
 Statistics from fitting evaluation of the learning organization model, employee commitment, and the operating results in research and development organization

Goodness-of-fit measure	Recommended value	Structural model (result)
$\chi^2$ test statistic/df	$\leq 3.000$	1.205 ( $p = .140$ )
GFI	$\geq 0.900$	0.975
AGFI	$\geq 0.900$	0.953
CFI	$\geq 0.900$	0.997
NFI	$\geq 0.900$	0.984
RMSEA	$\leq 0.080$	0.024
SRMR	$< 0.050$	0.021
TLI	$\geq 0.900$	0.996

**Table 3**  
 Direct and indirect effects of variables

Dependent variable	R <sup>2</sup>	Effect	Independent variable		
			LO <sup>a</sup>	OM <sup>b</sup>	OP <sup>c</sup>
Employee commitment	0.490	Direct Effect	0.700	0.000	0.000
		Indirect Effect	0.000	0.000	0.000
		Total	0.700	0.000	0.000
Operating results	0.801	Direct Effect	0.846	0.069	0.000
		Indirect Effect	0.048	0.000	0.000
		Total	0.894	0.069	0.000

**Note:** <sup>a</sup>Learning organization, <sup>b</sup>Organizational commitment, <sup>c</sup>Organizational performance

and development organization must have an updated and accessible database of competency and expertise in order to gather information, knowledge and learning in the organization. Empowering supports a commitment at all levels of personnel in administration and management, including a commitment to propose visions, aims, and goals and in particular, goals that are similar to the demands of the consumers and the market. Internal and external circumstances affect the system of the organization, so the organization adjusts itself (Watkins & Marsick, 1993, 1996). Most budget for research and development organizations in Thailand is allocated by the Thai government. Moreover, the government provides effective and strict assessments, and continuously improves key performance indicators based on changing technology, and competitors in order to allocate this budget for more concrete research and development. Finally, leaders play an important role in the development of the learning organization. This notion conforms to Davenport and Prusak (2000), Naot, Lipshitz, and Popper (2004), and Watkins and Marsick (1993).

According to this study, the operating results of a research and development organization included four important aspects: mission, knowledge, finances, and innovation. These significantly influenced research and development. Operating results are the primary objective of an organization and they require evaluation in order to drive an organization according to the determined mission, objectives, goals, and aims. The results can be key performance indicators for the government agencies in charge of evaluating a research and development organization. In terms of operating results, the research and development organization is responsible for inventing, creating, and constructing new knowledge through research and development. The government's primary objectives are to provide opportunities for learning, perceiving, and distributing knowledge, and improving the skills of personnel, as well as applying knowledge in manufacturing to respond to consumer and social demands, especially by maintaining knowledge in the organization, society, and country. With regard to financial operating results, the capabilities of a research and development organization are evaluated for their benefit in comparison to their properties. These capabilities include decreasing payments and costs and increasing the effectiveness of work. Most research and development organizations are run in response to the needs of the community and country. Thus, one characteristic of a non-profit organization is to evaluate operating results in applying research and development to solve the problems of the country as well as to support people to be able to depend on themselves using science and technology. For innovative operating results, research and development organizations continuously produce and invent products and services which is one of the most important key performance indicators evaluated by a third party assigned by government.

According to Meyer, Allen, and Gellathly (1990), a learning organization directly and positively influences employee commitment. This conforms to the hypothesis of Tseng (2010) who stated that the best practices of a learning organization are the wisest way to increase the

effectiveness of an organization. Well-developed employee commitment can enhance the effectiveness of the organization. Lim (2003) stated that the culture of a learning organization is related to positive relations, employee commitment, and satisfactory work in both internal and external manners. The results of the study explain the variables of employee commitment. Emotional commitment refers to the personnel commitment to an organization and to the feeling of memberships and ownership. Most personnel in research and development organizations are government officers who are strongly committed to their organization. They tend not to leave because of the stability and services provided to them and their families. This is consistent with the theory of Meyer et al. (1990) who stated that the relationship with an organization is a reflection of interest, effort to understand, and clear recognition of contribution. Commitment to a social standard in an organization refers to personnel's realization of the importance and appreciation of their organization. They would like to improve themselves to serve their organization which is a commitment of employment. Most government research and development organizations are supported by the government to maintain the length of employment for employees. If personnel are committed to their organizations, it is less likely they will leave the organization. Mowday, Steer, and Porter (1979) believe that commitment increases manufacturing capability and supports quality service. Finally, commitment to continuous employment refers to a person's understanding of what is being provided by their organization, and their willingness to give back in return. Government officers serve the people, society, and country and are supported by the national budget, so they understand that they should do their duty with loyalty and serve the country in a concrete way.

## Conclusion and Recommendation

From this study, it can be concluded that learning organization has a direct effect on employee commitment and the operating results of a research and development organization. The structural equation model revealed that the seven variables of learning organization directly and significantly influenced the operating results and employee commitment; however, commitment had no direct effect on operating results or performance.

Based on the results of this study, scientific technology and development policy and planning should consider applying learning organization to improve the performance of research organizations. This study focused on quantitative research. It is recommended that qualitative research be used to gain more information through in-depth interviews or focus groups. Other factors that have an effect on organizational performance such as employee engagement, the work environment, and competition from external factors should be considered in future research.

## Conflict of interest

None.



## References

- Alipour, F., Idris, K., Ismail, I. A., Uli, J. A., & Karimi, R. (2011). Learning organization and organizational performance: Mediation role of intrapreneurship. *European Journal of Social Sciences*, 21(3), 61–67.
- Davenport, T., & Prusak, L. (2000). *Working knowledge: How organizations manage what they know*. Boston, MA: Harvard Business School Press.
- Demers, D. L. (2009). *The relationship between perceptions of LO characteristics and firm performance* (Doctoral dissertation). Retrieved from <https://etda.libraries.psu.edu/catalog/9373>.
- Herrera, D. A. (2007). *A validation of the LO as a driver of performance improvement* (Unpublished doctoral dissertation). Capella University, Minneapolis, MN.
- Lim, T. (2003). *Relationships among organizational commitment, learning organization culture, and job satisfaction in one Korean Private Organization* (Unpublished doctoral dissertation). The University of Minnesota, Minneapolis, MN.
- Martinez, R. L. (2009). *Impact of LO on financial performance* (Unpublished doctoral dissertation). Capella University, Minneapolis, MN.
- Meyer, J., & Allen, N. (1991). A three-component conceptualization of organization commitment. *Human Resource Management Review*, 1(1), 61–89.
- Meyer, J., Allen, N., & Gellathly, I. (1990). Affective and continuance commitment to the organization: Evaluation of measures and analysis of concurrent and time-lagged relations. *Journal of Applied Psychology*, 75, 710–720.
- Mowday, R., Steers, R., & Porter, L. (1979). The measurement of organizational commitment. *Journal of Vocational Behavior*, 14, 224–247.
- Naot, Y., Lipshitz, R., & Popper, M. (2004). Discerning the quality of organizational learning. *Management Learning*, 34(4), 451–472.
- National Research Council of Thailand. (2012). *Annual report 2012*. Bangkok, Thailand: Author
- Schein, E. (1993). On dialogue, culture, and organizational learning. *Organizational Dynamics*, 22(2), 40–51.
- Schumacker, R. E., & Lomax, R. G. (1996). *A beginner's guide to structural equation modeling*. Mahwah, NJ: Lawrence Erlbaum Associates.
- Senge, P. (1990). *The fifth discipline: The art and practice of the learning organization*. New York, NY: Doubleday.
- Senge, P., & Joni, S. (2005). Outsight insight: Balancing private and public inquiry. *Reflections*, 6(1), 1–10.
- Senge, P., Scharmer, C., Jaworski, J., & Flowers, B. (2004). *Presence: Human purpose and the field of the future*. Cambridge, MA: SoL Press.
- Song, J. H. (2008). *The integrative determinants of OP improvement: The impacts of dimensions of LO and dynamic knowledge creation* (Unpublished doctoral dissertation). The Pennsylvania State University, PA.
- Sudharatna, Y., & Hongladarom, C. (2006). *The study of learning organization characteristics in the auto industry, Thailand*. Bangkok, Thailand: The Thailand Research Fund.
- Tseng, C. C. (2010). *The effects of learning organization practices on organizational commitment and effectiveness for small and medium-sized enterprises in Taiwan* (Unpublished doctoral dissertation). The University of Minnesota, Minneapolis, MN.
- UNESCO Institute for Statistics. (2011). Global investment in R&D. *UIS Fact Sheet*, 15.
- Watkins, K., & Marsick, V. (1993). *Sculpting the learning organization: Lessons in the art and science of systemic change*. San Francisco, CA: Jossey-Bass.
- Watkins, K., & Marsick, V. (1996). *In action: Creating the learning organization*. Alexandria, VA: American Society for Training and Development.
- Wiratchai, N. (1999). *LISREL model: Statistics for research* (3rd ed.). Bangkok, Thailand: Chulalongkorn University Press. [in Thai]