

THE DESIGN OF TUNGSTEN MINE ENVIRONMENT MONITORING SYSTEM BASED ON WIRELESS SENSOR NETWORKS

Mungara Karthik Babu*¹, Jada Lingaiah²

¹M. Tech Student, Arjun College of Engineering, Hyderabad (A.P), India.

²Asst. Prof (HOD), Dept. of Comunication Engineering, , Arjun College of Engineering, Hyderabad (A.P), India.

ABSTRACT

Tungsten is usually mined underground. Tungsten's unique high-temperature properties can be utilized advantageously in the production of numerous end-use items. In this project we use different modules at transmitter end such as Zigbee module, LPC2148 as controller, smoke Sensor, Temperature sensor, Moisture sensor, a buzzer to indicate the leakage of hazardous gases and display the presence of gas on 16X2 LCD on the transmitter side. If any gas exceeds the value automatically using advanced wireless zigbee technology. This project uses sensors such as smoke Sensor, Temperature sensor (LM35). Whenever hazardous gas is detected, a buzzer is connected to produce audible alert signal. And the sensor values are given to ADC to get processed by LPC2148 controller. The temperature sensor LM35 senses the temperature and converts it into an electrical (analog) signal, which is applied to the micro controller through ADC. The analog signal is converted into digital format by the analog-to-digital converter (ADC). And a pair of moisture sensors is used to monitor the leakage of hazardous gas leakage in tungsten mines.

Keywords: Sensors, Wireless Sensor Network, Control Unit, Hyperterminal.

1. INTRODUCTION

Currently, environmental monitoring system of mine is widely used in industrial bus, to connect underground monitoring system with ground information center by cable or fiber optic to constitute a wire monitoring network. But it always exists cabling problems. WSN is a technology which is based on low-power wireless communication technology, embedded computing, micro-sensor technology and integrated circuit technology. It is an intelligent network system [1] that is widely distributed in certain region, concluding a large number small sensor node which has wireless communication and computing abilities and could independently complete the assigned tasks by selforganization according to the environment. WSNs have some characteristics of none-center, self-organization, dynamic topology, and numbers of nodes, high density, and limited hardware resources. These make WSNs have a good potential in the environmental monitoring, medical care, military and so on. The mine environment monitoring system based on WSNs can solve the problem of routing and can achieve the monitoring of multi-point to multi-point. Mining has been perceived an extremely dangerous yet necessary occupation around the world. Hazardous mining environments generally refer to the presence of dangerous gases within an underground mine. Mine Air quality system has to check frequently the presence of hazardous gases and temperature in tungsten mines. The most common method employed to continuously monitor for leakage of hazardous gases is to place a number of sensors at the places where any leaks are most likely to occur. If it detects the presence of dangerous gases automatically it gives information at the receiver side.

2. BLOCK DIAGRAM

2.1 Transmitter Section

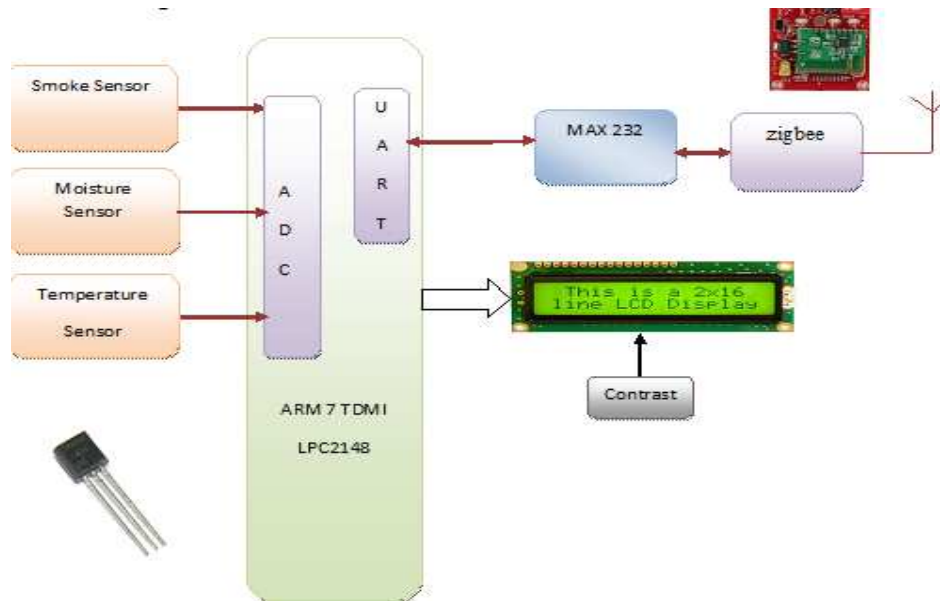

2.2 Receiver section

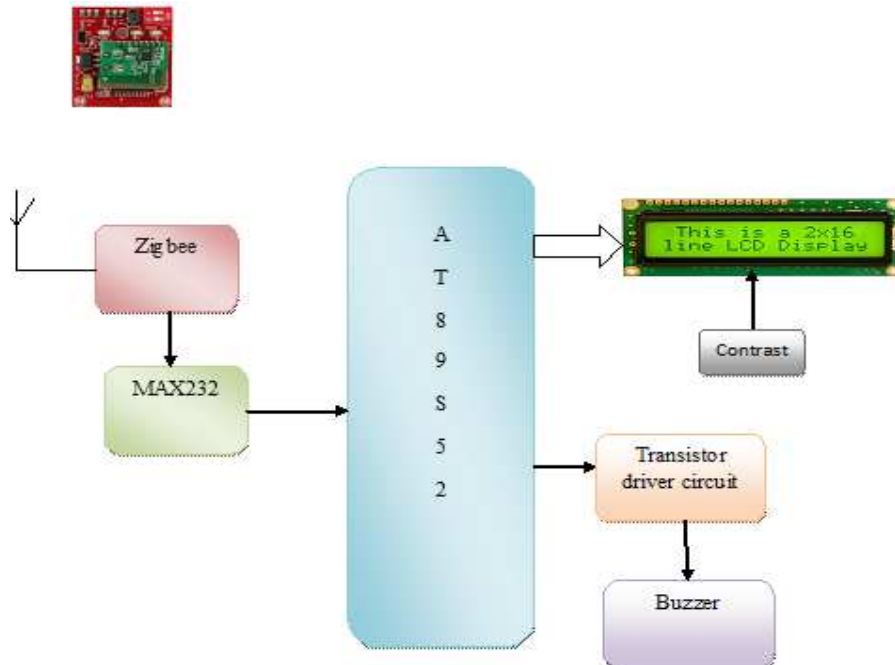

3. WIRELESS SENSOR NETWORK STRUCTURE DESIGN

The whole monitoring system can be divided into two parts, wireless part and wired part, in other words, underground part and ground part [4]. The design mainly completed the design of wireless part. In the wireless part of the underground, according to nodes' function and level, nodes are divided into sensor nodes, cluster head nodes and gateway node. Sensor nodes are responsible for the collection of environmental parameters, and sending the collected data. Cluster head nodes are mainly designed by the special environment of mine. Generally mine is not a straight line and exists corners and branches. In order to ensure the data transmit effectively while the shortest distance is sent to the gateway node, cluster head nodes are arranged at the corner of the mine tunnel and wellhead. The main function of cluster head nodes is to send and receive data without the data collection so as to save resources at the same time to

extend the life of the network nodes. The gateway node plays a central role in wireless sensor networks. It is responsible for wireless sensor networks and computer communications, on one hand it receives the data from the wireless sensor networks, on the other hand it is connected with the Ethernet and sends to the monitoring center (IPC) [7]. Thus it could arrange sensor nodes under tungsten mine flexibly based on this design, the various safety indicators within the mine could be sent by cluster head nodes to the gateway node directly or indirectly. Then via the internet the gateway node uploads the data to the ground monitoring center.

4. MICRO-PROCESSOR MODULE

Micro-processor module was the computer controlling core of WSNs nodes. Collecting signals of environment parameters needed high sampling rate and large data volume, which was decisive in node design. So its processor should meet small volume, high integration, low consumption and high performance.

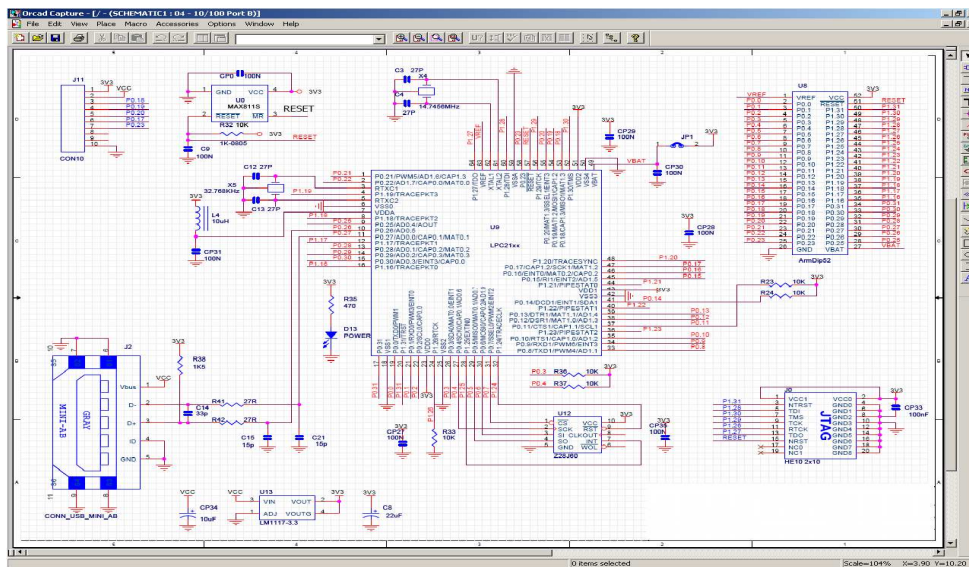

4.1 ARM7 LPC2148

The LPC2141/42/44/46/48 microcontrollers are based on a 16-bit/32-bit ARM7TDMI-CPU with real-time emulation and embedded trace support, that combine microcontroller with embedded high speed flash memory ranging from 32 kB to 512 kB [6]. A 128-bit wide memory interface and unique accelerator architecture enable 32-bit code execution at the maximum clock rate. For critical code size applications, the alternative 16-bit Thumb mode reduces code by more than 30% with minimal performance penalty. Due to their tiny size and low power consumption, LPC2141/42/44/46/48 are ideal for applications where miniaturization is a key requirement, such as access control and point-of-sale. Serial communications interfaces ranging from a USB 2.0 Full-speed device, multiple UARTs, SPI, SSP to I2C-bus and on-chip SRAM of 8 kB up to 40 kB, make these devices very well suited for communication gateways and protocol converters, soft modems, voice recognition and low end imaging, providing both large buffer size and high processing power. (3) Various 32-bit timers, single or dual 10-bit ADC(s), 10-bit DAC, PWM channels and 45 fast GPIO lines with up to nine edge or level sensitive external interrupt pins make these microcontrollers suitable for industrial control and medical systems.

4.2 Liquid Crystal Display (LCD)

LCD stands for Liquid Crystal Display. LCD is finding wide spread use replacing LEDs these components are “specialized” for being used with the microcontrollers, which means that they cannot be activated by standard IC circuits [7]. They are used for writing different messages on a miniature LCD. A model described here is for its low price and great possibilities most frequently used in practice. It displays all the alphabets, Greek letters, punctuation marks, mathematical symbols etc. In addition, it is possible to display symbols that user makes up on its own. Automatic shifting message on display (shift left and right), appearance of the pointer, backlight etc. are considered as useful characteristics.

4.3 Network Communication Protocol

System followed the rules IEEE802.15.4 and ZigBee protocol. ZigBee is a communication protocol with close distance, low complexity, low consumption, low data transfer speed, low cost, high reliability. According to the characteristic of geographical conditions of mining, dynamic topology of WSN and multi-hop routing, the network topology structure used the tree or net topologies.

4.4 Temperature Sensor (LM 35)

The LM35 series are precision integrated-circuit temperature sensors, whose output voltage is linearly proportional to the Celsius (Centigrade) temperature. The LM35 thus has an advantage over linear temperature sensors calibrated in ° Kelvin, as the user is not required to subtract a large constant voltage from its output to obtain convenient [3] Centigrade scaling. The LM35 does not require any external calibration or trimming to provide typical accuracies of $\pm 1/4^{\circ}\text{C}$ at room temperature and $\pm 3/4^{\circ}\text{C}$ over a full -55 to $+150^{\circ}\text{C}$ temperature range.

4.5 Moisture Sensor (Dry and Wet sensor):

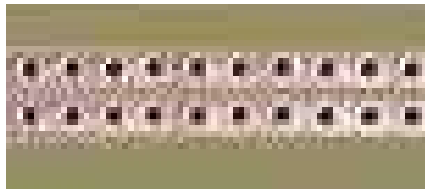

Soil moisture sensors measure the water content in soil. A soil moisture probe is made up of multiple soil moisture sensors [2]. One common type of soil moisture sensors in commercial use is a Frequency domain sensor such as a capacitance sensor. Another sensor, the neutron moisture gauge, utilize the moderator properties of water for neutrons. Cheaper sensors -often for home use- are based on two electrodes measuring the resistance of the soil. Sometimes this simply consists of two bare (galvanized) wires, but there are also probes with wires embedded in gypsum.

5. SOFTWARE ARCHITECTURE AND IMPLEMENTATION

5.1 Orcad

OrCAD is a proprietary software tool suite used primarily for electronic design automation. The software is used mainly to create electronic prints for manufacturing of printed circuit boards, by electronic design engineers and electronic technicians to manufacture electronic schematics. The name OrCAD is a portmanteau, reflecting the software's origins: Oregon + CAD.

5.2 Keil Micro vision 3 IDE

The μ Vision development platform is easy-to-use and it helps you quickly create embedded programs that work [4]. The μ Vision IDE (Integrated Development Environment) from Kiel combines project management, source code editing, program debugging, and complete simulation in one powerful environment. Code written in 'EMBEDDED C'

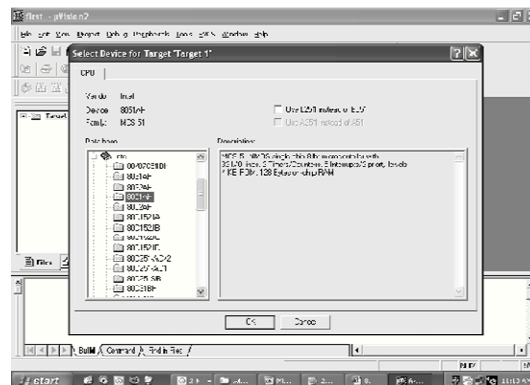

Implementation of Keil Software

The μ Vision3 IDE and Debugger is the central part of the Keil development tool chain. μ Vision3 offers a Build Mode and a Debug Mode. In the μ Vision3 Build Mode you maintain the project files and generate the application.

5.3 Flash Magic Software

The method to download Hex File into Flash Memory of MCU in Board is to use Program Flash Magic that is connected with MCU through Serial Port of computer PC.

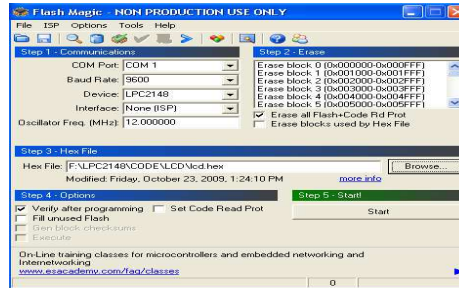

Implementation of Flash Magic software

6. CONCLUSION

This project presents The Design of Tungsten Mine Environment Monitoring System Based on Wireless Sensor Networks Based On Embedded Technology. It is designed and implemented with LPC2148 CONTROLLER in embedded system domain. Experimental work has been carried out carefully. The result shows that higher efficiency is indeed achieved using the embedded system.

REFERENCES

- [1] Zhang XP, Liu GX, He XW. LSSVR target localization method in WSN modeling on signal strength difference to eliminate the target power influence. Journal of Harbin Engineering University 2009; 30(12): 1414 -1419.
- [2] Wang Q, Chen L, Zhong Q, Liu Y. Application of cognitive radio to wireless sensor networks in underground coalmine. Transducer and Microsystem Technologies 2009; 28(8): 113-115.
- [3] Li Z, Shi H. Design and Realization of the Wireless Sensor Network Node Based on ATmega128L. Computer Engineering and Applications 2006; (27): 76-79.
- [4] Chen L, Liu X, Dai J, Zhao D. Design of Coal Mine Temperature Measuring and Controlling System Based on Wireless Sensor Networks. Instrument Technique and Sensor 2008; 12: 87- 89.
- [5] SHT1x SHT7x Humidity, Temperature Sensor datasheet, Switzerland, Sensirion Company, 2004.
- [6] Sun H, Teng ZS. Based on temperature and humidity sensors SHT10 monolithic test module design. Foreign Electronic Measurement Technology 2006; 25(6): 43-46.
- [7] Qi Q, Ma B, Han Z, Zhao J. Detection of Indoor Temperature and Humidity of Intelligent Building Based on SHT11. Low Voltage Apparatus 2008; 18: 1-3.
- [8] Zhang H. Sensor Application Design 300 cases (Volume), Beijing: Beijing Aeronautics and Astronautics Press, 2008.
- [9] Zhang C, Zhu Y, Chen Y. Design of Wireless CO2 Sensor Networks Based on ZigBee for Greenhouses. Industrial Control Computer 2009; 22(10): 36-37.
- [10] Xu Y, Zhulin A, Jiang W, Jiang P. Practice Guide to Wireless Sensor Networks. Beijing: Beijing Institute of Technology Press, 2007.
- [11] Chipcon AS SmartRF CC2420 Preliminary Datasheet (rev 1.4), 2006; 5.