



# Microgrid Protection Using Communication-Assisted Digital Relays

Eric Sortomme, *Student Member, IEEE*, S. S. Venkata, *Life Fellow, IEEE*, and Joydeep Mitra, *Senior Member, IEEE*

**Abstract**—Microgrids have been proposed as a way of integrating large numbers of distributed renewable energy sources with distribution systems. One problem with microgrid implementation is designing a proper protection scheme. It has been shown that traditional protection schemes will not work successfully. In this paper a protection scheme using digital relays with a communication network is proposed for the protection of the microgrid system. The increased reliability of adding an additional line to form a loop structure is explored. Also a novel method for modeling high impedance faults is demonstrated to show how the protection scheme can protect against them. This protection scheme is simulated on a realistic distribution system containing a high penetration of inverter connected Distributed Generation (DG) sources operating as a microgrid. In all possible cases of operation the primary and secondary relays performed their intended functions including the detection of high impedance faults. This system is simulated using Matlab Simulink's SimPowerSystems toolbox to establish the claims made in this paper.

**Index Terms**—Digital relay, distribution communication, distribution systems, high impedance fault, microgrid, protection.

## I. INTRODUCTION

ONE proposed way of integrating high penetration of DG sources is through microgrids. A microgrid is defined as a low to medium voltage network of small load clusters with DG sources and storage [1]. Microgrids can operate in islanded mode or grid-connected mode. If a microgrid is connected to the system, it is seen as a single aggregate load or source. One of the potential advantages of a microgrid is that it could provide more reliable supply to customers by islanding from the system in the event of a major disturbance. The microgrid protection in islanded operation poses a serious problem. It was shown in [2], [3] that the fault currents for a grid-connected and islanded microgrid are significantly different. Additionally, high penetration of inverter connected DG sources lead to conditions where no standard overcurrent protection methods will suffice.

Manuscript received May 18, 2009; revised September 19, 2009. First published December 11, 2009; current version published September 22, 2010. Paper no. TPWRD-00376-2009.

E. Sortomme and S. S. Venkata are with the Department of Electrical Engineering, University of Washington, Seattle, WA 98195 USA (e-mail: eric.sortomme@gmail.com; venkata@ee.washington.edu; ss.venkata@kema.com).

J. Mitra is with the Department of Electrical and Computer Engineering, Michigan State University, East Lansing, MI 48824 USA (e-mail: mitraj@msu.edu).

Color versions of one or more of the figures in this paper are available online at <http://ieeexplore.ieee.org>.

Digital Object Identifier 10.1109/TPWRD.2009.2035810

It is clear that protection of microgrids cannot be achieved with the same philosophies that have been used to protect traditional distribution systems. At the very least, a system designed to protect a microgrid should take the following into account: (a) bidirectional flow in feeders; (b) looped feeders; (c) reduced fault levels in islanded operation. In this work, therefore, every one of these three factors are described in greater detail in the next section; the essence of this work is summarized by stating that these factors are addressed through the following contributions: (1) A protection scheme using digital relays with a communication overlay is proposed for the protection of the microgrid system. A practical system, described in Section III, is chosen from [3], [4] to investigate the protection scheme. (2) The increased reliability of adding an additional line to form a loop structure is explored. (3) A novel method for modeling high impedance faults is demonstrated to show how the protection scheme can protect against them. This is important in microgrid protection not only because a the percentage of high impedance faults on the distribution system is not insignificant [5], but also because microgrids, in the islanded mode, typically have lower fault currents, and methods of high impedance fault detection will be useful for the detection of these faults.

## II. PROTECTION SCHEME

### A. The Case for a New Protection Paradigm

Most distribution systems are operated in radial mode. The majority of these are radially connected; others may have loop closing feeders, but the loops are kept open by normally open switches that are closed only when other parts of the loops are opened because of faults. Hence, the radial structure is preserved. Consequently, in these systems, the protection is designed for radial operation. However, as the penetration of distributed resources increases, these systems will experience two important changes: (a) bidirectional flow in the feeders, and (b) looped operation. Traditional protection schemes for radial operation will no longer be adequate. Nor can one apply traditional protection schemes that are in use even in meshed distribution systems today, because the new protection systems will have to be adaptive, since as the system switches between grid-connected and islanded (as single or multiple islands) modes, the (i) configuration and (ii) fault levels will change. A logical solution that accommodates all these changes is a communication-assisted system.

### B. General Microgrid Protection Philosophy

Since a microgrid can operate in a grid-connected mode and in an islanded mode, it is necessary to protect it in both modes of

operation. The general philosophy is to find a method that will work equally well in both modes of operation. There are different philosophies of protecting islanded microgrids. One is to simply trip the entire microgrid offline once the fault is detected during islanding since it is an  $(N - 2)$  failure; the first failure being the loss of the feeder. For additional reliability, the faulted line will need to be removed from service and the remaining connected loads and sources will operate as two smaller islands. This will only work if the generation and load in each smaller system match. If higher reliability is required, the feeders can be connected as a loop, so the loss of a feeder or a lateral will not result in service disruption to customers. The higher reliability, however, comes at a higher cost.

Several methods of protecting microgrids have been previously proposed. One scheme is to have each DG source have its own relay and operate without communications [6]. This works well for single line-to-ground faults and line-to-line faults. It relies on the sum of the phase and neutral currents as well as zero sequence currents. However, it fails to detect some high impedance faults. Another proposed scheme is to use a voltage protection scheme [7]. In this case, the phase voltages at the DG source are transformed into the 'dq0' synchronous frame, and then compared against a reference. A voltage drop against the reference initiates switching device tripping. For multiple DG sources, the voltages are compared via an undefined communication link and the lowest relative voltage part is tripped. This method is also ineffective against high impedance faults. An additional protection scheme utilizes standard overcurrent differential protection on each line with backup voltage and frequency protection at each DG source [8]. This scheme is also unable to detect high impedance faults (HIF's). In addition, each of the aforementioned schemes has only been tested on relatively small systems with few buses and undefined distances between distribution lines.

Additionally, it has been proposed that replacing overcurrent relays with directional relays in instances where a problem of directionality exists is possible; but this comes at a high cost. Individual DG's could also be tripped at the first detection of a fault before the distribution relays can operate [9]. The problem with directional relays is that they will also not detect HIF's. Tripping DG sources also reduces the reliability of service to the customer.

It has also been proposed that microgrids could participate in remedial action schemes using synchronized phasor measurements to determine the appropriate islanding and restoration strategies. These protection schemes however are under development and currently not ready for deployment [9].

### C. Proposed Protection Scheme

The protection scheme proposed in this work utilizes some of the principles of synchronized phasor measurements and microprocessor relays to detect all types of fault conditions including HIF's. It is based on the deployment of digital distribution feeder relays that are currently offered by some of the major manufacturers. These digital relays include standard overcurrent and over/under voltage protection methods. They are programmable and have fiber optic and Ethernet communication links. They are self metering and have oscillographic event

reports [10]. By using these relays on the end of each line segment, a very robust protection scheme can be developed. Although the work reported in this paper used digital relays, it is conceivable that the use of properly designed sensors and switches will perform adequately for faults encountered in distribution systems, and enable cost-effective protection schemes. The costs can be further controlled by not using specific communication channels, but by 'piggy-backing' on any available channels already deployed in that part of the system. For instance, if 'smart grid' technologies have already been deployed, the corresponding communication channel can be used. The primary protection scheme utilizes a relay that measures absolute current sampled at 16 or higher number of samples per cycle and then transmitted via communication link to the relay on the other side of the line. For distances under 18 miles, the transmission takes less than 0.1 ms based on the speed of light for signal transmission and several additional microseconds for processing time. This is sufficient for most distribution systems. This means that there is no need to get time-synchronized measurements from both sides of the line for short distribution lines. For lines longer than 18 miles, however, a Phasor Measurement Unit (PMU) may be required. In this way a differential relaying scheme is successfully created.

The primary protection for each feeder relies on instantaneous differential protection. If absolute values of two samples are found to be above the trip threshold, the tripping signal is sent to the switching device. It is anticipated that these switching devices will benefit from recent advances in switching technologies (such as vacuum interrupters) and higher sampling rates, and it should soon be possible to interrupt currents much faster than the present-day norm of 3–5 cycles. The expected fault currents can vary over a wide range: less than to many times greater than the nominal load current (0.5–20 p.u.). The current transformers will therefore need to have accurate operation over this wide range of fault currents.

In the event of a switching device failure, a backup trip signal will be sent to the adjacent relays on the same bus. This signal is sent after a certain time delay, greater than 0.3 seconds but less than 0.6 seconds, if the measured differential current is still above the threshold. This is the normally accepted practice, but with the advent of high performance relays and breakers the delay could be significantly shorter. If the relay or the communication link fails, this will alert all other connected relays that the differential scheme is lost. An alarm will be sent to the distribution control center. The remaining relays will rely on comparative voltage protection until the system is restored. The comparative voltage protection compares the relative rms voltage at each relay with every other connected relay. For voltages less than 0.7 p.u., the relay with the lowest voltage will trip after a 0.6 second but less than 0.9 second time delay. This allows the first two schemes to operate. Each DG source is also equipped with undervoltage tripping for voltages less than 0.7 p.u. and after one second delay. This protection scheme is depicted in Fig. 1.

The protection scheme can detect HIF's in two ways. The first way relies on the high sensitivity of the current transformers. As long as the HIF current magnitude is at least 10% of the nominal current, the HIF will be detected by the differential protection

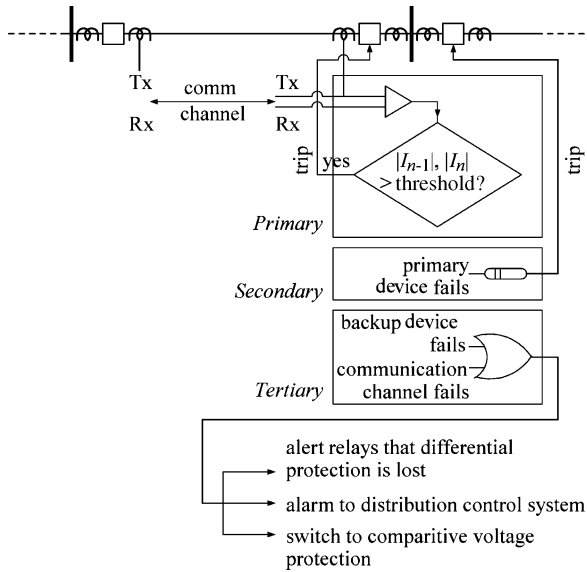

Fig. 1. Conceptual representation of proposed protection scheme.

scheme. The other method relies on programming the relays to recognize certain HIF characteristics that have been observed and then tripping when those characteristics are present in the differential current.

### III. A NEW MODEL FOR HIGH IMPEDANCE FAULTS

High impedance faults (HIF's) have traditionally been difficult to model and detect. They exhibit buildup, shoulder, non-linearity, and asymmetry. Additionally, they are stochastic or nonlinearly deterministic in nature [11]–[13]. The bulk of the work on HIF's has been on modeling the waveform and the harmonics for detection purposes [5], [13]–[16]. The problem with these methods of HIF modeling is that they neglect the stochastic elements inherent in the fault conditions such as 'dancing' wires on asphalt or trees blowing in the wind. Because of these conditions, the HIF's will also have completely random elements that can drastically change the current envelope, as well as add small variations to it.

Therefore, in this paper a novel way of modeling HIF's is proposed to provide further insight into the HIF fault behavior. This model relies on randomly varying the magnitude of the fault resistance and its duration. The resistance is varied randomly between 50 and 1000  $\Omega$ . The duration of each resistance value is randomly varied between 10  $\mu\text{s}$  and 5 ms. This way the true randomness of HIF's can be captured. A deterministic time-decay component is added in series with the fault resistance to model the buildup and shoulder behavior. Two additional deterministic resistances assure negative cycle asymmetry and zero crossing clipping.

To test the HIF model proposed here, a simple test system with a 564 kVA source feeding two 282 kVA loads connected radially with two distribution lines is constructed. The fault is initiated midway on the furthest line from the source. A simulated fault current waveform is shown in Fig. 2. The expanded fifth through seventh cycles of this waveform can be seen in Fig. 3. From these figures it can be seen that the model captures both the deterministic and stochastic elements of HIF's

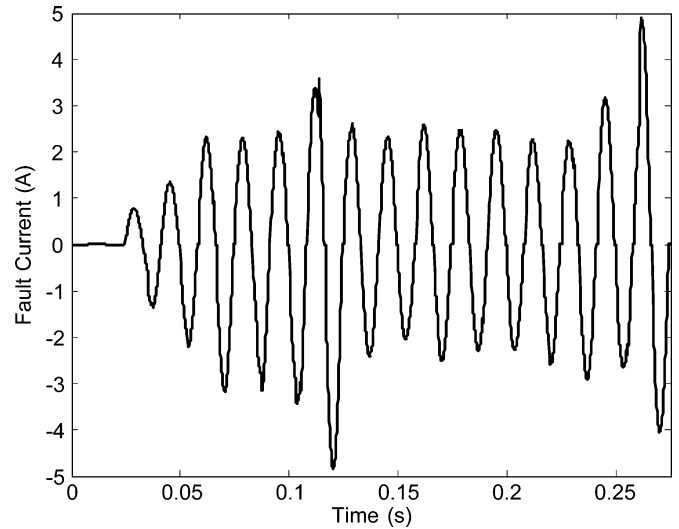

Fig. 2. Current waveform of randomly varying HIF resistance.

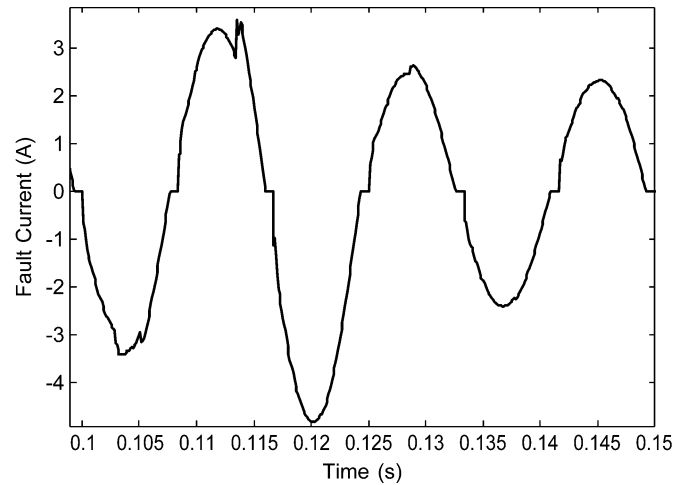

Fig. 3. Fifth through seventh cycles of the HIF current in Fig. 2.

described in the literature [5], [11]–[16]. However, further field or high-voltage laboratory testing will be required to validate this model for specific HIF types. These tests will be conducted using different materials with high impedance. Specific conditions (tree falling on wire, cut wire from automobile collision) will also need to be simulated to tune the model parameters to these specific types of HIF's. The model can then be used to simulate the desired HIF.

### IV. MICROGRID APPLICATION SYSTEM

A practical test system as shown in Fig. 4 is used in this study. It is an 18-bus distribution system shown in [4] that has been converted to a microgrid by adding multiple DG sources [3]. The source models are taken from standard Matlab Simulink blocks and examples. A more detailed description of the models is given in [3]. The system carries 3.03 MVA of unbalanced load and is connected to a 10 MVA transformer. Bus loads are shown in Table I. There are four inverter-connected solar arrays; two wind turbines, and one diesel generator connected at different buses. The solar arrays are connected to three-phase inverters

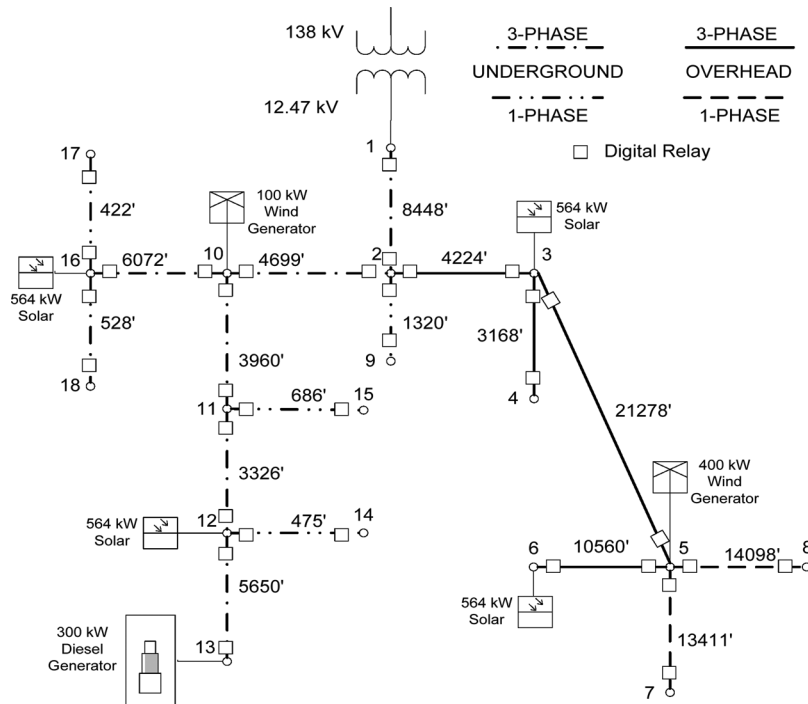

Fig. 4. One line diagram of the microgrid with added DG sources.

TABLE I  
BUS LOADS FOR THE MICROGRID IN Fig. 1, BLANK AREAS INDICATE  
UNCONNECTED PHASES

BUS	Phase A		Phase B		Phase C	
	P (kW)	Q (kvar)	P (kW)	Q (kvar)	P (kW)	Q (kvar)
3	117	73	121	65	90	98
4	97	33	86	35	91	36
6	46	15	77	23	64	19
7	100	65				
8			85	32		
9					354	180
13	75	34	75	34	75	34
14	111	53				
15					176	34
16	89	63	89	63	89	63
17			314	126		
18	210	99				

and provide a total of 2,256 kW. The wind turbines are induction generators and provide 500 kW. When islanded, additional generation is provided by the 300 kW diesel generator. This attempts to model a realistic distribution system that, through the addition of customer owned DG, is converted to a microgrid.

With the microgrid radially connected as in Fig. 4, the reliability is easily compromised with any fault. A fault on the line between busses 5 and 6, for example, will remove a large solar array from service. This will result in an approximately 350 kW generation deficiency for the microgrid if it is islanded. Similar generation deficiencies will be observed for a removal of any line while operating in an islanded mode. To mitigate this problem an additional line is added to form a loop structure. This line should be added where it connects as many DG sources as possible to the central ring of the loop for maximum reliability. For the test system used in this study, this is between buses 6

and 13. This new system is shown in Fig. 5. A microgrid with a loop structure is protected against  $(N - 2)$  contingencies or failures. Additionally a loop structure will also help the reliability of the system in steady state operation, though it is not the focus of this paper.

## V. SIMULATION AND RESULTS

The test system is simulated in Matlab Simulink's SimPowerSystems. The system is simulated using Simulink's ode3 with a fixed time step of 1 microsecond. A comprehensive fault analysis is performed for all locations on the system and all four fault types. Single line-to-ground high impedance faults are also simulated. Additionally, the cases of switching device and relay failure are simulated to test the efficacy of backup protection system. The particular case of a line-to-ground (L-G) fault midway between busses 3 and 5 is described in detail for all of the four cases discussed below. Voltage and current measurements are taken on bus 10 to demonstrate the effectiveness of the proposed scheme. The system is simulated on four different scenarios; grid connected and islanded with the system configured radially, as in Fig. 4, and grid connected and islanded configured in a loop structure, as in Fig. 5.

### A. Radial and Islanded Case

In this case, the primary protection scheme has no difficulty isolating all fault types. The relays are able to detect all solid faults after two samples and trip within the cycle. The current and voltages as measured at bus 10 for normal relay operation for an L-G fault on the 'A' (solid line) phase are shown in Fig. 6. on line 2–10. The differential fault current as measured at the bus 3 relay on line 3–5 is shown in Fig. 7. It can be seen from Fig. 6 that after the fault is cleared, there is voltage droop due to under generation on the remaining islanded network. This

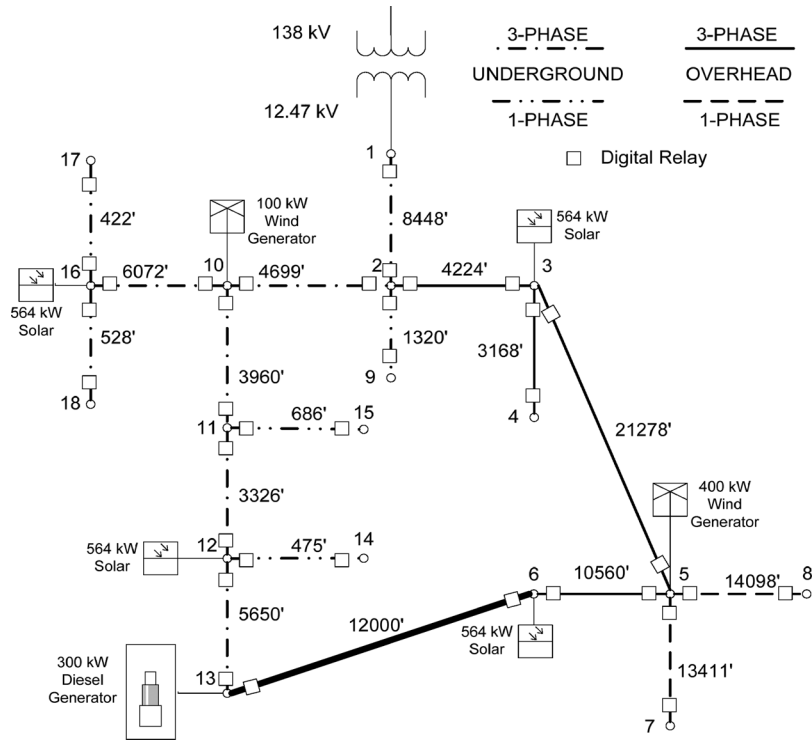

Fig. 5. One line diagram of the microgrid with an additional line between buses 6 and 13 making a loop structure.

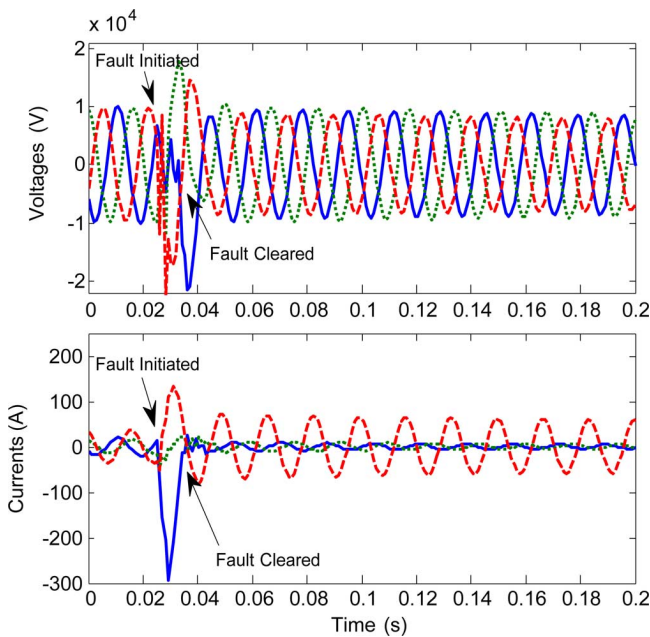

Fig. 6. Voltages and currents for line 2–10 for an L-G fault on line 3–5 with primary relay operation. Microgrid state is islanded with radial structure.

type of waveform is typical for the radial connected system. In all fault locations, there is a resulting over generation on one sub-island and an under generation on the other. This scenario demonstrates the need for a loop structure which can maintain the generation balance under loss of line conditions.

The case of a primary switching device failure at the same location as above is shown in Figs. 8 and 9. The fault persists

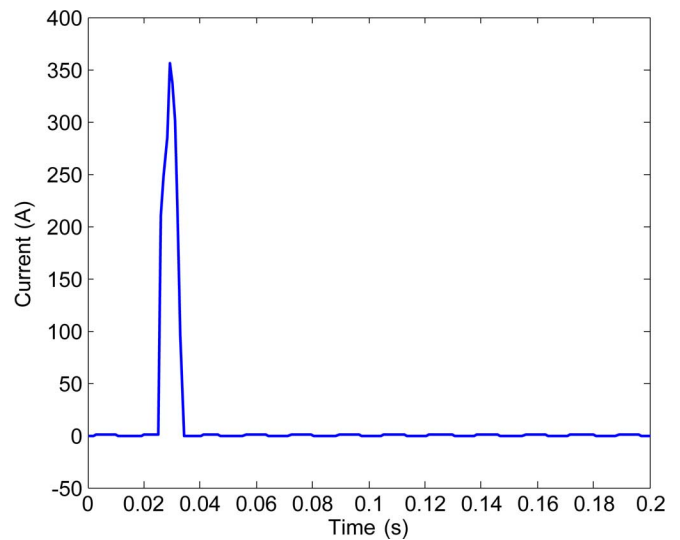

Fig. 7. Differential current measured at the relay at bus 3 on line 3–5. Microgrid state is islanded with radial structure.

for an additional 0.3 s before being cleared. Also, since the secondary or backup operation trips additional loads and generation offline, the only current flowing on line 2–10 is to feed the ‘C’ phase load at bus 9. Similar voltage waveforms are observed at all other locations for this case with different current flows depending on the location.

The case of a relay failure, tertiary protection, is shown in Fig. 10. The fault current in this case persists for 0.6 s before it is cleared. The resulting voltages and currents are otherwise the same as in the case of the switching device failure.



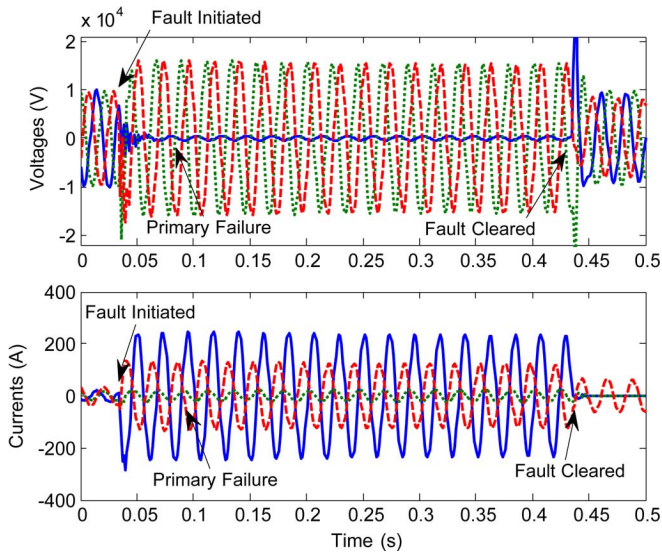

Fig. 8. Voltages and currents for line 2–10 for an L-G fault on line 3–5 with the primary switching device failure and successful backup trip. Microgrid state is islanded with radial structure.

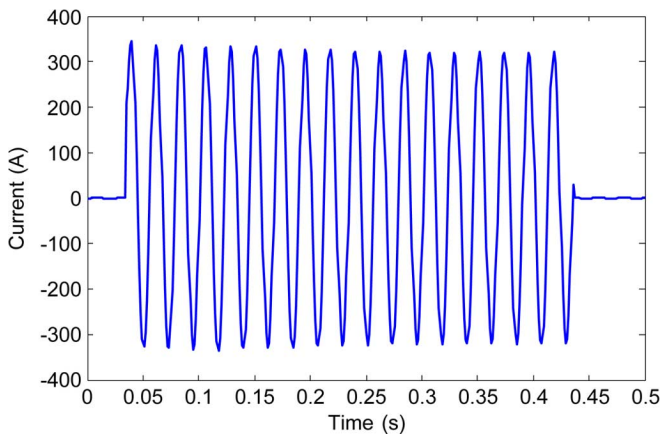

Fig. 9. Differential current at the relay at bus 3 on line 3–5 with a switching device failure and a successful backup trip. Microgrid state is islanded with radial structure.

### B. Radial and Grid Connected Case

The main difference in the grid connected mode of operation to the islanded mode is that the portion of the microgrid still connected to the main grid has a perfect generation load match since the additional power can either be sent to the system or received from it. However, that portion separated from the grid in this case always has too much or too little generation which can cause a loss of the load. The transients experienced by the system are also larger since the system has a much larger short-circuit capacity than the DG sources. Voltage and current waveforms for the L-G fault are shown in Fig. 11. Notice there is no voltage droop associated with clearing the fault.

### C. Loop Structure and Islanded Case

The loop structure allows additional reliability, especially to loads in the main loop. For faults on any of the loop lines, all

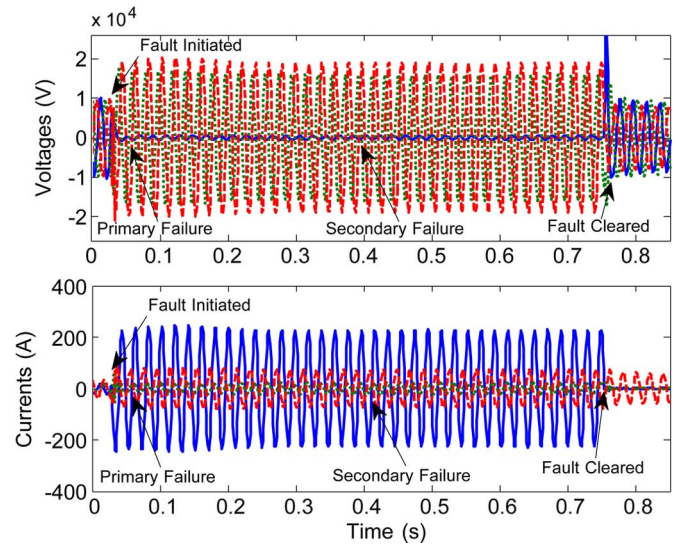

Fig. 10. Voltage and currents for line 2–10 for an L-G fault on line 3–5 with primary relay failure and backup voltage operation. Microgrid state is islanded with radial structure.

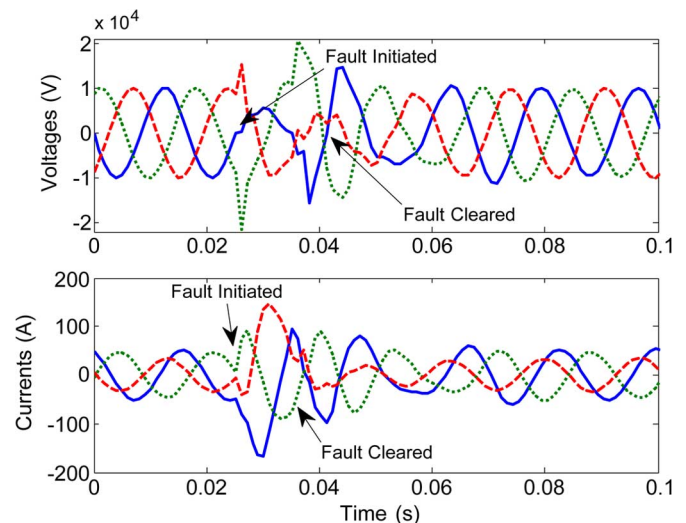

Fig. 11. Voltages and currents for line 2–10 for an L-G fault on line 3–5 with primary relay operation. Microgrid state is grid connected with radial structure.

loads remain in service and the generation load balance is maintained as long as the primary protection operates. The transients are greater largely due the reversal of power flow along many of the lines the instant the switching devices open. Voltages and currents for the L-G fault with normal operation are shown in Fig. 12. After the switching device opens, there is no accompanying voltage droop on the lines verifying the additional reliability added to the system by the loop.

### D. Loop Structure and Grid Connected Case

This is largely the same as the loop structure when islanded. The transients are larger due to the higher short circuit capacity of the system. The voltages and currents for the L-G fault on with successful primary relay operation are shown in Fig. 13. Notice the unusually high 'A' phase current (solid line) due to

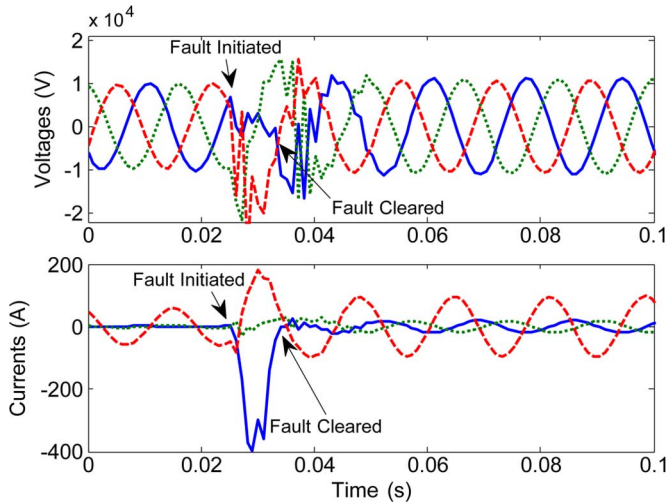

Fig. 12. Voltages and currents for line 2–10 for an L-G fault on line 3–5 with normal relay operation. Microgrid state is islanded with loop structure.

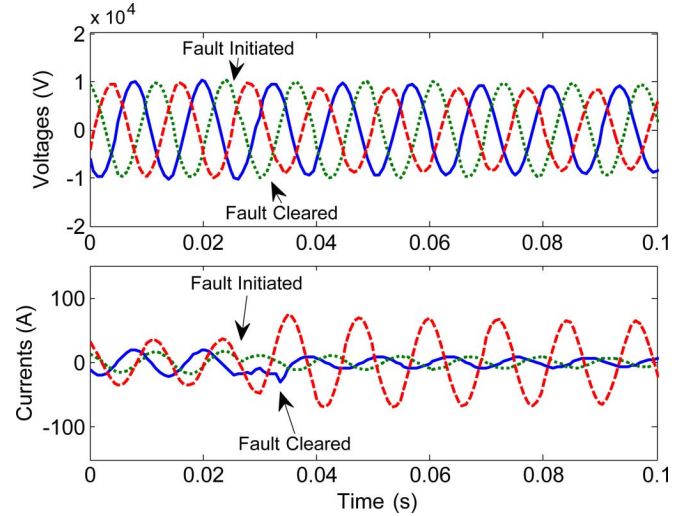

Fig. 14. Voltages and currents for line 2–10 for a HIF on line 3–5 with normal relay operation. Microgrid state is islanded with radial structure.

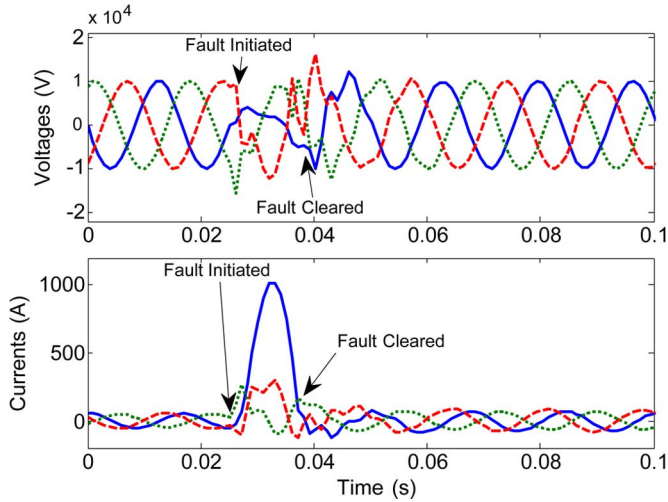

Fig. 13. Voltages and currents for line 2–10 for an L-G fault on line 3–5 with normal relay operation. Microgrid state is grid connected with loop structure.

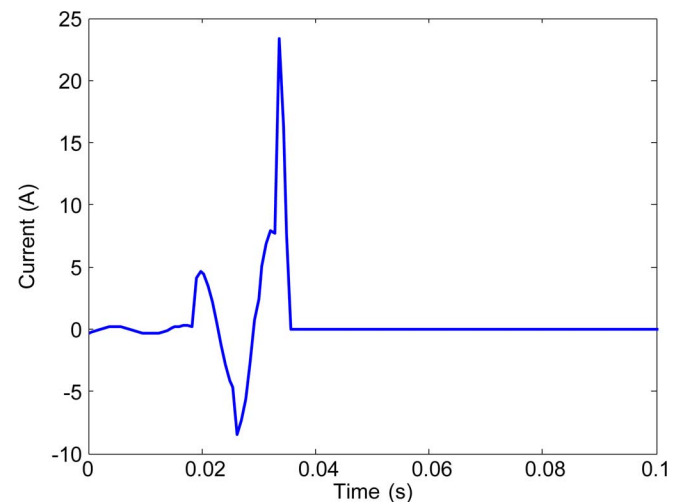

Fig. 15. Differential current the relay at bus 3 on line 3–5 for a HIF with normal operation. The current threshold was 6 A.

the reduced line impedance to the fault as a result of the connecting loop.

### E. High Impedance Faults (HIF's)

For HIF's, the relays are able to detect the current difference as long as the total fault current is greater than 10% of the nominal primary current. This nominal current in some cases is only 20 A. These differences are able to be detected since the current transformers are operating near their nominal level and thus are in the linear region where error is small. Voltage and current waveforms for a high impedance line to ground fault on 'A' phase are shown in Fig. 14 and differential current at the relay is shown in Fig. 15.

## VI. DISCUSSION

The proposed protection scheme is clearly able to protect a microgrid in all modes of operation with an improvement in reliability. This is especially true with the loop configuration as

the radial configuration usually has generation-load imbalance with the removal of any line due to a fault. However, it is clear that placing these relays and switching devices on each line tap in a distribution system would, in most cases, not be economically justifiable. Another method that uses the same principles is to have only sensor units at the buses with a communication link to the substation. At the substation, a central controller or logic processor such as the one described in [18] can monitor the current and voltage differences and remotely operate the switching devices. Additionally, any lines that will not experience bidirectional current flow will only need one switching device instead of two, thus further reducing the cost. This scheme will work exactly the same as with multiple relays and for similar faults, similar responses as those previously discussed will be observed. In the event of a communication failure, however, the only protection will be on the sources which will work for all but HIF's. Though even this scheme is still more expensive than traditional protection methods, it is justified if the customers require the additional reliability of islanding.

## VII. CONCLUSION

In this paper, a digital relay scheme with a communication overlay is proposed to protect microgrids with customer owned DG sources. The proposed protection system relies primarily on differential protection based on sampling the current waveform at 16 samples per cycle or more. A new and novel model for HIF's using random duration and time varying resistances is also presented. This model is shown to accurately capture the behavior of HIF's which has been observed in previous literature. A loop structure is also shown to increase reliability against  $(N - 2)$  contingencies while a radial configuration is shown to easily collapse when islanded. The loop structure is shown to be most effective when it connects that maximum possible number of DG sources to the central loop. The simulation of the protection scheme shows that it is able to quickly detect and clear all faults including HIF's with current of at least 10% of the nominal current, at all locations. Based on the research work and results presented in this paper, the improved reliability can be obtained with a central controller with communication to multiple measurement units for a reduced cost without installing explicit relays at each end of every line. An optimum strategy for the number of relays and their location can be evaluated based on the network topology at the location and ratings of the DG sources.

## REFERENCES

- [1] *European SmartGrid Technology Platform, Vision and Strategy for Europe's Electricity Networks of the Future*, EU Commission, Directorate-General for Research, Information and Communication Unit, Brussels, Belgium, 2006.
- [2] T. C. Green and J. D. McDonald, "Modeling and analysis of fault behavior of inverter microgrids to aid future fault detection," in *Proc. IEEE Int. Conf. Syst. Eng.*, 2007, pp. 1–6.
- [3] E. Sortomme, G. J. Mapes, B. A. Foster, and S. S. Venkata, "Fault analysis and protection of a microgrid," in *Proc. North Amer. Power Symp.*, 2008, Sep. 2008, pp. 1–6.
- [4] Cooper Power Systems, Ed. 3, *Electrical Distribution-System Protection*, Cooper Industries, 1990.
- [5] C. G. Wester, *High Impedance Fault Detection on Distribution Systems*, General Electric Company, 2008 [Online]. Available: <http://pm.geindustrial.com/faq/documents/f60/ger-3993.pdf>, [Accessed: Sep. 11, 2009]
- [6] H. Nikkhajoei and R. H. Lasseter, "Microgrid protection," in *Proc. IEEE Power Eng. Soc. General Meeting*, Jun. 2007, pp. 1–6.
- [7] M. A. Redfern and H. Al-Nasseri, "Protection of micro-grids dominated by distributed generation using solid state converters," in *Proc. IET 9th Int. Conf. Develop. Power Syst. Protection*, 2008, pp. 670–674.
- [8] H. H. Zeineldin, E. F. El-Saadany, and M. M. A. Salama, "Distributed generation micro-grid operation: Control and protection," in *Proceedings of the Power Systems Conference: Advanced Metering, Protection, Control, Communication, and Distributed Resources*, 2006, Mar. 2006, pp. 105–111.
- [9] *Power System Relaying*, S. H. Horowitz and A. G. Phadke, Eds., 3rd ed. Hertfordshire, U.K.: Baldock, 2008, p. 259.

- [10] Schweitzer Engineering Laboratories, Inc., SEL-751A Feeder Protection Relay Jun. 2008 [Online]. Available: <http://www.selinc.com/WorkArea/DownloadAsset.aspx?id=3812>, [Accessed: Sep. 3, 2009]
- [11] F. Chen, K. B. Athreya, V. V. Sastry, and S. S. Venkata, "Function space valued Markov model for electric arc furnace," *IEEE Trans. Power Syst.*, vol. 19, no. 2, pp. 826–833, May 2004.
- [12] E. O'Neill-Carrillo, G. T. Heydt, E. J. Kostelich, S. S. Venkata, and A. Sundaram, "Nonlinear deterministic modeling of highly varying loads," *IEEE Trans. Power Del.*, vol. 14, no. 2, pp. 537–542, Apr. 1999.
- [13] S. Ekles, *Detecting High-Impedance Faults*, El-Paso Electric Co., 2009 [Online]. Available: <http://www.elp.com/index/display/article-display/341599/s-articles/s-utility-automation-engineering-td/s-volume-13/s-issue-10/s-features/s-detecting-high-impedance-faults.html>, [Accessed: Sep. 11, 2009]
- [14] T. M. Lai, L. A. Snider, and W. C. Lo, "Wavelet transform based relay algorithm for the detection of stochastic high impedance faults," *Electr. Power Syst. Res.*, vol. 76, no. 8, pp. 626–633, 2006.
- [15] S. R. Nam, J. K. Park, Y. C. Kang, and T. H. Kim, "A modeling method of a high impedance fault in a distribution system using two series timevarying resistances in EMTF," in *Proc. IEEE Power Eng. Soc. Summer Meeting*, Vancouver, BC, Canada, Jul. 2001, vol. 2, pp. 1175–1180.
- [16] N. I. Elkalashy, M. Lehtonen, H. A. Darwish, M. A. Izzularab, and A. I. Taalab, "Modeling and experimental verification of high impedance arcing fault in medium voltage networks," *IEEE Trans. Dielectr. Electr. Insulat.*, vol. 14, no. 2, pp. 375–383, Apr. 2007.
- [17] R. H. Lasseter, "Certs microgrid," in *Proc. IEEE Int. Conf. Syst. Syst. Eng.*, 2007, pp. 1–5.
- [18] Schweitzer Engineering Laboratories, Inc., SEL-3378 Synchronphasor Vector Processor Jun. 2008 [Online]. Available: <http://www.selinc.com/WorkArea/DownloadAsset.aspx?id=2830>, [Accessed: Sep. 4, 2009]



**Eric Sortomme** (S'08) was born in Ephrata, WA, on September 22, 1981. He received the B.S. degree (*magna cum laude*) in electrical engineering from Brigham Young University, Provo, UT, in 2007. He is currently pursuing the Ph.D. degree at the University of Washington, Seattle, with research emphasis on SmartGrid technologies and wind power integration. His employment experience includes internships with Wavetronix LLC and Puget Sound Energy. He has authored or co-authored three additional technical publications.

**S. S. (Mani) Venkata** (M'68–SM'77–F'89–LF'08) is an affiliate Professor of Electrical Engineering at the University of Washington, Seattle. He is also the president of Venkata Consulting Solutions, Inc.

**Joydeep Mitra** (S'94–M'97–SM'02) received the B.Tech. (hons.) degrees in electrical engineering from Indian Institute of Technology, Kharagpur, India, and the Ph.D. degree in electrical engineering from Texas A&M University, College Station.

He is Associate Professor of Electrical Engineering and Faculty Associate of the Institute of Public Utilities at Michigan State University, East Lansing. Prior to this, he was Associate Professor at New Mexico State University, Las Cruces, Assistant Professor at North Dakota State University, Fargo, and Senior Consulting Engineer at LCG Consulting, Los Altos, CA. His research interests include power system reliability, distributed energy resources, and power system planning.