

# Suggested Methods for Determining the Strength of Rock Materials in Triaxial Compression: Revised Version

## 1. SCOPE AND INTRODUCTION

Three different types of triaxial compression test are described. The tests are intended to measure strength of cylindrical rock specimens as a function of confining pressure. The three test types differ from each other in the manner by which the strength envelope is produced (Figs 1a–c). With test type I (“individual test”), individual points on the failure (peak strength)<sup>1\*</sup> envelope are obtained from several tests (Fig. 1a)<sup>2</sup>, while with test type II (“multiple failure state test”) (Fig. 1b) and test type III (“continuous failure state test”) (Fig. 1c) the envelope is produced with a single test employing a stepwise or continuous procedure<sup>2</sup>. The information obtained from a single specimen increases thus from type I to type III; requirements on testing equipment are greater for test types II and III than for test type I. The suggested procedures do not contain provisions either for pore pressure measurements or for drainage of the specimen. If an effect of pore pressures is suspected, this should be tentatively investigated by running tests at different moisture contents; if this shows further evidence of pore pressure effects, appropriate modifications to the testing procedure will be required<sup>3</sup>.

The suggested methods described here supersede those published in an earlier document.

## 2. APPARATUS

### 2.1. General testing equipment

The testing equipment is, with a few specifically mentioned exceptions, the same for all test types and consists essentially of the following parts (Fig. 2).

\* Numbers in superscript refer to Notes at the end of the text.

### 2.2. Loading device for applying and controlling axial load<sup>4</sup>

A stiff loading machine<sup>5</sup> should preferably be used for applying and measuring the axial load in the rock specimen. It should be of sufficient capacity to fail the specimen at the selected confining pressure of pressure range and capable of applying the strains at a selected rate. It shall be calibrated at suitable time intervals<sup>4</sup>.

### 2.3. Triaxial cell

This comprises (Fig. 3):

(a) A triaxial cell to apply confining pressure to the specimen, of design similar to one of the three alternatives shown in Fig. 3.

(b) Platens having a Rockwell hardness of not less than C30 shall be placed at both specimen ends. The diameter of the platens shall be between  $D$  and  $1.02D$  where  $D$  is the diameter of the specimen. The thickness of the platens shall be at least 15 mm or  $D/3$ . Surfaces of the platens should be ground and polished, and their flatness should be  $\pm 0.005$  mm.

(c) Spherical seatings shall be located in each of the platens<sup>6</sup>. The centre of curvature of the seating surfaces should coincide with the centre of the specimen ends. The spherical seats should be lightly lubricated with mineral oil. The specimen, the platens and the spherical seats shall be centred with respect to one another.

(d) A flexible membrane of suitable material<sup>7</sup> shall be used to prevent the confining fluid from entering the specimen; the membrane shall not penetrate significantly into the surface pores and it should be sufficiently long to extend well on to the platens. When slightly stretched it should be the same diameter as the specimen.

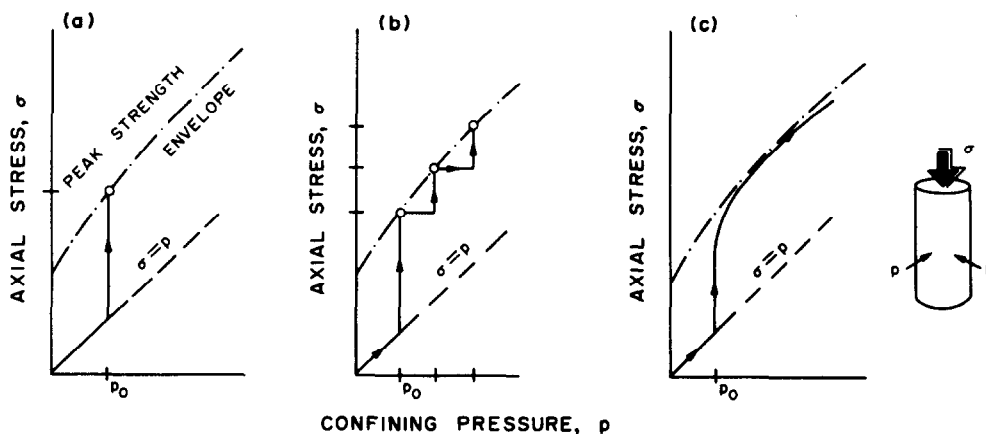

Fig. 1. Different triaxial test types: (a) Type I—individual test; (b) Type II—multiple failure state test; (c) Type III—continuous failure state test.

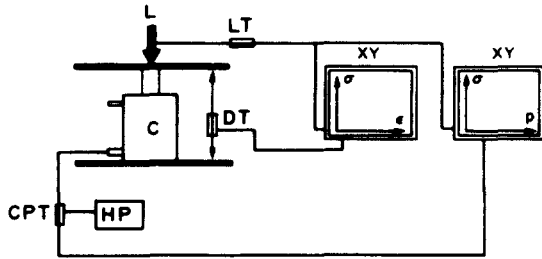

Fig. 2. A schematic diagram of the test equipment.

- L = Axial load.
- LT = Load transducer.
- C = Triaxial cell.
- DT = Deformation transducer (optional in test type I).
- CPT = Confining pressure transducer.
- HP = Device for applying confining pressure.

2.4. Device for applying confining pressure

A hydraulic pump or some other system of sufficient capacity and capable of fine regulation of the pressure to within  $\pm 1\%$  shall be used.

2.5. Equipment for measuring and recording loads, pressures and displacements

This includes:

- (a) Provision for continuous measurement of axial load.
- (b) Pressure indicating devices (pressure gauges or pressure transducers) shall be employed to measure confining pressure. It is advisable to use at least two indicators with ranges approximately 0–15 and 0–70 MPa<sup>8</sup>.

For test type I, confining pressure needs to be kept constant and does not have to be continuously recorded. For test types II and III, continuous recording of confining pressure is necessary which requires pressure transducers for measurement.

(c) For measuring and recording axial displacement of the specimen, a displacement transducer shall be used. This makes continuous measurement and recording of axial displacements possible, which is required for test types II and III and desirable in test type I.

(d) Axial load, axial displacement and confining pressure can be either read intermittently or recorded continuously. In the latter case x–y recorders or analogous real time equipment shall be used. In test type I only axial load and displacement vary and one continuous recording device or readout devices for intermittent reading are sufficient. Test types II and III require continuous recording and control of all data; two x–y recorders are thus recommended, one recording axial load versus axial displacement, the other axial load versus confining pressure.

3. PREPARATION OF THE TEST SPECIMEN

(a) Test specimens shall be right circular cylinders having a length to diameter ratio of between 2.0 and 3.0 and a diameter preferably of not less than NX core size (approximately 54 mm). The diameter of the specimen should be related to the size of the largest grain in the rock whenever possible by a ratio of at least 10:1.

(b) The ends of the specimen shall be cut and ground parallel to each other and at right angles to the longitudinal axis.

(c) The ends of the specimen shall be flat to  $\pm 0.01$  mm and shall not depart from the perpendicular to the longitudinal axis of the specimen by more than 0.001 radian (about 3.5 min) or 0.05 mm in 50 mm.

(d) The sides of the specimen shall be smooth and free of abrupt irregularities and straight to within 0.3 mm over the full length of the specimen.

(e) The use of capping materials or end surface treatments other than machining is not permitted.

(f) The diameter of the test specimen shall be measured to the nearest 0.1 mm by averaging the diameters measured at right angles to each other at approximately the top, the mid-height and the bottom of the specimen. The average diameter shall be used for calculating the cross-sectional area<sup>16</sup>. The height of the specimen shall be determined to the nearest 1.0 mm.

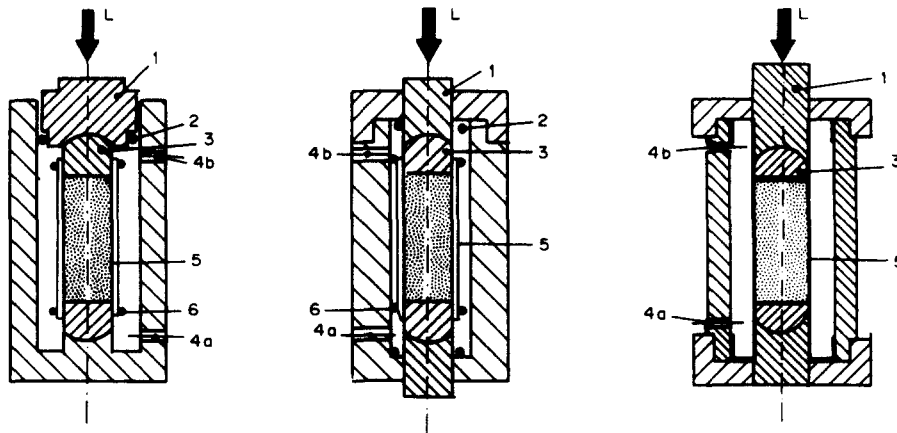

Fig. 3. Three possible designs for triaxial chamber.

- 1 = Loading piston.
- 2 = Seals.
- 3 = Platens with spherical seating.
- 4a = Hydraulic connection.
- 4b = Bleeder hole.

L = Load applied by loading device.

- 5 = Flexible membrane.
- 6 = "O"-ring clamps.

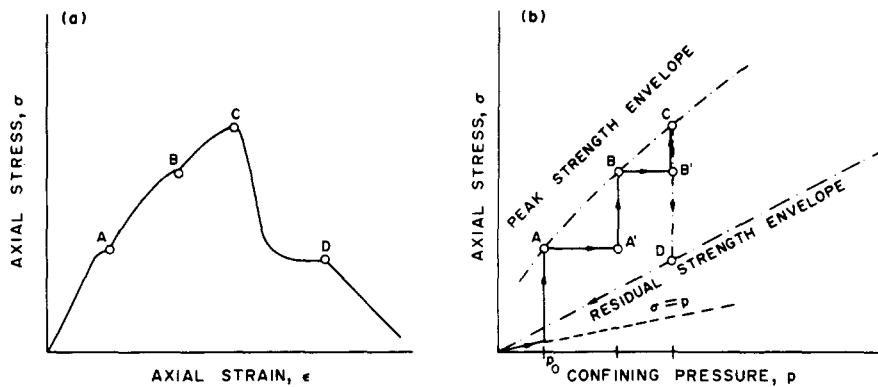

Fig. 4. Multiple failure state triaxial test: (a) The axial stress–axial strain curve; (b) the axial stress–confining pressure curve.

(g) Specimens shall be stored for no longer than 30 days, in such a way as to preserve, as far as possible, the natural water content until the time of specimen preparation<sup>9</sup>. The moisture content shall be reported in accordance with “Suggested methods for determination of the water content of a rock sample”, Method 1 ISRM Committee on Laboratory Test, Document No. 2, Final Draft, November, 1972.

(h) The number of specimens should be sufficient to adequately define the strength envelope over the required range of confining pressures. The number needed for this purpose will depend on the test method selected (1, 2 or 3), on the intrinsic variability of the rock and on the application in which the data is to be employed.

#### 4. PROCEDURES

##### 4.1. General

The following procedure applies to each of the three test types (see Fig. 2):

(a) Prepare the recording equipment if employed. Choose scales and calibrate x–y recorder(s) or other readout devices.

(b) Assemble specimen, platens, membrane, triaxial cell and load pressure and displacement measurement devices. The exact procedure will depend on triaxial cell design and on type and location of the measurement devices.

(c) Connect the hydraulic line and fill the triaxial cell with oil, allowing the air to escape through an air bleeder hole. Close the air bleeder hole.

(d) Place the triaxial cell in the axial loading device.

(e) Select the initial confining pressure.

##### 4.2. Procedure type I—individual test

(a) The axial load and the confining pressure should normally be increased simultaneously until the predetermined level for the confining pressure is reached<sup>10,11</sup>.

(b) The axial load on the specimen shall correspond to a constant strain rate such that failure will occur within 5–15 min of loading. Alternatively, the stress rate shall be within the limits of 0.5–1.0 MPa/sec.

(c) The maximum axial load and the corresponding confining pressure on the specimen shall be recorded.

However, it is advisable to record axial load and displacement continuously.

##### 4.3. Procedure type II—multiple failure state test

(a) Apply the initial confining pressure  $p_0$ . The axial load and the confining pressure should normally be increased simultaneously until the hydrostatic pressure reaches the value of the initial confining pressure  $p_0$ <sup>10</sup>.

(b) The axial load is then increased keeping confining pressure  $p_0$  constant<sup>11</sup> until the corresponding peak strength is observed in the axial stress–axial strain curve (Point A, Fig. 4a)<sup>12</sup>. The axial load shall be increased continuously at a constant strain rate within the limits of  $10^{-2} \text{ sec}^{-1}$  to  $10^{-5} \text{ sec}^{-1}$ .

(c) The confining pressure is then increased manually in one step, i.e. from A to A' in Fig. 4(b). This is followed by an axial load increase using the procedure described in 4.3(b) above.

(d) The stepwise procedure described in 4.3(b) and 4.3(c) is continued until a chosen point C (Fig. 4) is reached. The confining pressure will then be kept constant while the axial loading is continued. This will cause failure, and the axial stress will drop to its residual value (Point D, Fig. 4)<sup>13</sup>.

(e) The confining pressure is continuously reduced until the specimen is completely unloaded (Fig. 4). The axial stress versus confining pressure curve will follow the residual strength envelope. Test type II, whose procedures have just been described, and test type III make it possible to obtain the entire or at least a substantial portion of the peak strength envelope with a single test. However, the control features and expertise required for test type III exceed those of test type II, a fact that has to be considered in selecting the testing procedure.

##### 4.4. Procedure type III—continuous failure state test

(a) Apply the initial confining pressure  $p_0$ . The axial load and the confining pressure should normally be increased simultaneously until the hydrostatic pressure reaches the value of the initial confining pressure  $p_0$ <sup>10</sup>.

(b) The actual load is then increased keeping confining pressure  $p_0$  constant<sup>11</sup> until the corresponding peak strength is observed (Point A, Fig. 5) in the axial stress–axial strain curve<sup>12</sup>. The axial load on the speci-

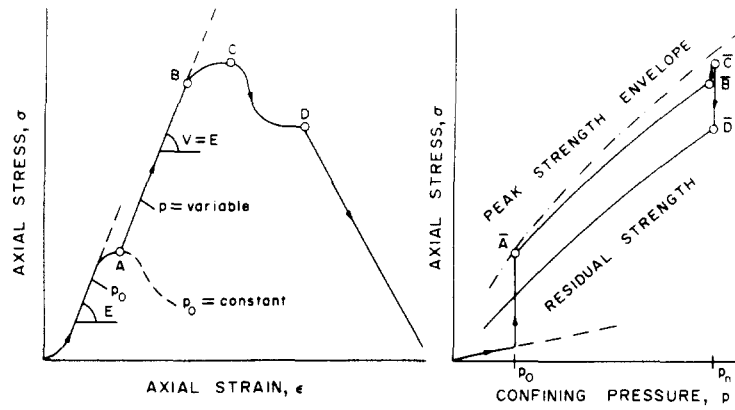

Fig. 5. Continuous failure state triaxial test.

men shall be increased continuously at a constant strain rate within the limits of  $10^{-2} \text{ sec}^{-1}$  to  $10^{-5} \text{ sec}^{-1}$  such that point A will be reached within 5–15 min of loading.

(c) A straight line AB (Fig. 5a) parallel to the linear portion of the initial axial load–deformation curve is drawn starting from the peak point A<sup>15</sup>. Thus the slope  $V$  of this straight line will be  $V = E$ , whereby  $E$  stands for the slope of the linear portion of the initial axial load–deformation curve.

(d) While the axial load increases at the selected rate (see 4.4(b) above) the confining pressure is simultaneously increased such that the pen of the x–y recorder follows the line AB. The variable axial load and confining pressure are continuously recorded and plotted on the second x–y recorder.

(e) At a chosen point B (Fig. 5a) the confining pressure will be kept constant<sup>11</sup> ( $p = p_n$ ) while the axial loading is continued. As a result of this a deviation from the straight line AB will occur leading to failure at point C<sup>14</sup>. When further compressing the specimen the axial stress will drop to a residual value<sup>13</sup> (Point D, Fig. 5a).

The confining pressure is continuously reduced until the specimen is completely unloaded (Fig. 5). The axial stress versus confining pressure curve will follow a residual strength envelope<sup>13,15</sup>.

### 5. CALCULATIONS

(a) The axial stress shall be calculated by dividing the axial load applied to the specimen during the test by the original cross-sectional area computed in accordance with specification 3<sup>16</sup>.

(b) In test III, peak strength and residual strength envelopes are directly produced. Analogous envelopes can be obtained in test type I and type II by fitting curves through the individual data points (Figs 1a and b).

The peak strength and residual strength envelopes can be approximated mathematically by linear or, if required, bilinear expressions according to  $\sigma = m_i p + b_i$ . The position of the straight lines is fixed by the ordinate  $b_i$ , the tangent of the slope angle  $m_i$  and the range of confining pressure to which they apply (Fig. 6). Using parameters  $m$  and  $b$ , the internal friction angle  $\phi$  and value for the “hypothetical” or “apparent” cohesion  $c$

(in the sense of Coulomb’s failure theory<sup>17</sup>), may be calculated from

$$\phi_i = \arcsin \frac{m_i - 1}{m_i + 1}; \quad c_i = b_i \frac{1 - \sin \phi_i}{2 \cdot \cos \phi_i}$$

### 6. REPORTING OF RESULTS

The report shall include at least the following:

(a) Source of specimen, including: geographic location, depth and orientation, date and method of sampling. If possible a map showing the sampling point should be included.

(b) Lithologic description of the rock including its grain size.

(c) Details of the methods used for the test specimen preparation, also the history and environment of test specimen storage.

(d) Orientation of the loading axis with respect to specimen anisotropy, bedding planes, foliation etc.

(e) Water content and degree of saturation at time of test.

(f) Description of testing equipment (loading device, triaxial cell, device for applying and measuring confining pressure).

(g) Date of testing.

(h) Specimen diameter and height.

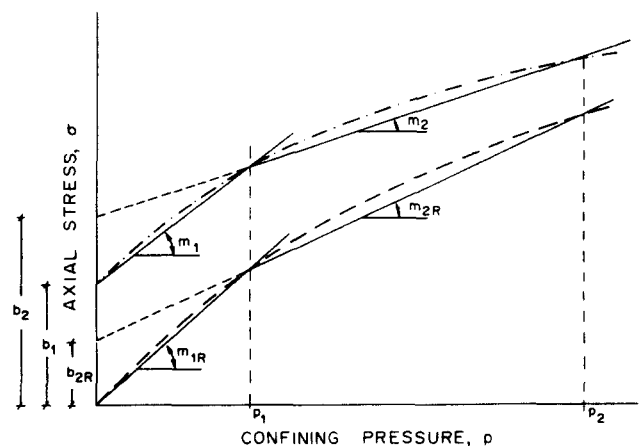

Fig. 6. The strength envelopes for peak and residual strength and their description by means of two straight portions with the parameters  $m_i$ ,  $b_i$  and  $m_{iR}$ ,  $b_{iR}$  respectively.

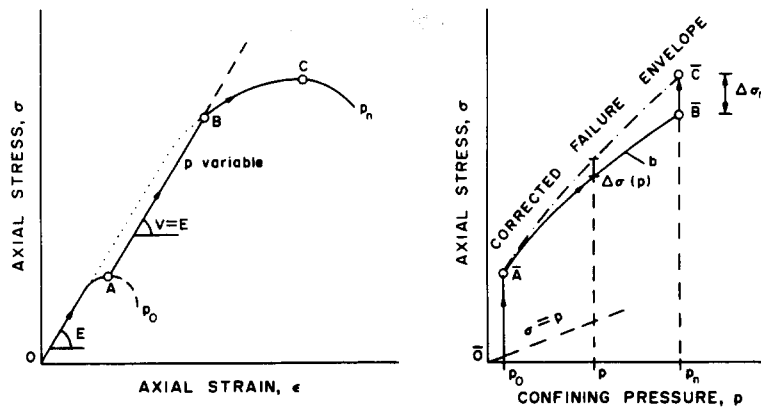

Fig. 7. Test Type III with a selected slope  $V = E$  leading into a pre-failure state with reserve of strength.

- (i) Test duration and/or stress and displacement rates.
- (j) The test plots in accordance with specification 2.4d, 4.2, 4.3 and 4.4. For "individual tests" (type I) also provide a table identifying the specimens and giving confining pressure and axial strength for each.
- (k) Mode of failure.
- (l) If desired the calculated values of  $c$  and  $\phi$  (for peak and residual strength respectively) together with the range of confining pressure in which they are valid.
- (m) Any other observations, e.g. density, porosity, citing the method of determination of each.

#### NOTES

1. Peak strength is defined as the maximum axial stress which the intact specimen can sustain at a given confining pressure.
2. Only the main differences between test types are given at this point, the detailed procedures are described in Section 4.
3. Pore pressure effects depend on rock type, moisture content and strain rate. For this reason no general recommendations regarding moisture content for the tentative tests or pore pressure effects can be given. Also, no generally applicable pore pressure testing and measurement procedures have been established.
4. Requirements for loading devices and related calibration procedures are given in national standards, e.g. "ASTM Method 4-64, Verification of Testing Machines", British Standard 1610: 1964, Grade A or the German Standards DIN 51 220, DIN 51 223 and DIN 51 300, class 1.
5. Stiff loading machines have stiffness above 0.2 MN/mm usually between 1 and 2 MN/mm. Loading machines are considered flexible if their stiffness is below 0.1 MN/mm. The use of a servo-controlled loading machine is recommended.
6. The concave halves of the spherical seats in the loading machines usually have no freedom of rotation. In order to align itself during installation, the specimen must have two spherical seats.
7. The membrane with a hardness of approximately 60-70 shore will be flexible enough to overcome re-

sistance due to the lateral deformation of the specimen.

8. The accuracy of the pressure gauges should be 4-5 times better than the pressure to be maintained.

9. It is recognized that in some cases for some materials it may be desired to test specimens under different moisture conditions. Such conditions shall be noted in the test report.

10. The procedure for increasing the confining pressure from zero to the required level depends on the testing equipment. Ideally the initial loading should be such that hydrostatic stress conditions are created in the specimen (i.e.  $\sigma = p$  for initial loading until the value  $\sigma = p_0$  is attained). If, however, during this "hydrostatic" loading the confining pressure should accidentally be higher than the axial stress, the loading piston may lose contact with the specimen (for example the spherical seating halves may separate) and the specimen may become misaligned. Friction in the apparatus may then prevent the specimen from returning to its proper position. Therefore, confining pressure and axial load are increased in such a way that the axial stress in the specimen always exceeds the confining pressure but by no more than one-tenth of the uniaxial compressive strength, until the prescribed value of confining pressure is reached.

11. Once the prescribed confining pressure is reached, it shall be maintained to within 2% of this value.

12. It is possible to record and plot either axial load against axial displacements or, to plot directly axial stress versus axial strain, or any other combination. What will be recorded and plotted depends on measurement equipment (e.g. displacement transducers or strain gauges) and calibration procedures.

13. The term residual strength is used here for the post failure strength at strains that can be reasonably obtained in triaxial tests. These strains may be insufficient to reach the "true" residual strength of some materials. If such "true" or "large displacement" residual strengths are required other types of tests have to be conducted.

14. The difference in axial stress  $\Delta\sigma_n$ , i.e. the increase of stress from point B to C represents a reserve of strength. Obviously the specimen passed through stress states along the curve  $b$  corresponding to prefailure conditions (Fig. 7). Therefore with a knowledge of the

stress increment  $\Delta\sigma_n$  the curve  $b$  should be corrected as follows

$$\sigma(p) = \Delta\sigma_n \frac{p - p_0}{p_n - p_0}$$

to reduce the difference between the "true" strength envelope and the curve  $b$ .

15. In cases of highly brittle materials or relatively low stiffness of the loading machine, abrupt failure at peak strength may occur. In such cases no curves for peak strength will be obtainable, only for the residual strength.

16. True axial stresses can only be obtained if lateral deformations are measured and the original cross-sectional area correspondingly corrected.

17. The cohesion  $c$  does not have here its usual physical significance, but simply serves to describe the failure envelope. In particular, it should be observed that

one cannot deduce the tensile strength of the material from the value of the apparent cohesion  $c$ .

Received 20 May 1983.

**REFERENCES**

1. Franklin J. and Hoek E. Developments in triaxial testing technique. *Rock Mech.* 2, 223-228 (1970).
2. Jaeger J. C. and Cook N. G. W. *Fundamentals of Rock Mechanics* Methuen, London (1976).
3. Kovari K. and Tisa A. Multiple failure state and strain controlled triaxial tests. *Rock Mech.* 7, 77-83 (1975).
4. Kovari K., Tisa A. and Attinger R. O. The concept of continuous failure state: triaxial tests. *Rock Mech. Rock Engng* 16(2), 117-131 (1983).

**APPENDIX A1**

*Multiple Failure State (Type II) Triaxial Test*

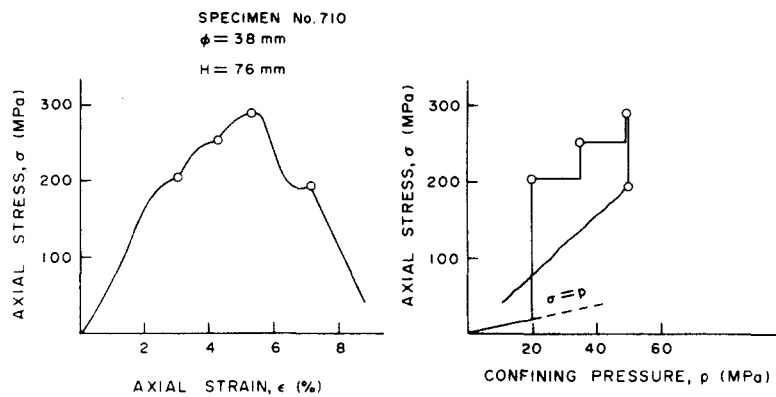

**APPENDIX A2**

*Continuous Failure State (Type III) Triaxial Test*

